

HyPerformance[®] Plasma *HPR800XD[®]*

Auto Gas

Instruction Manual

806500 – Revision 5

Register your new Hypertherm system

Register your product online at www.hypertherm.com/registration for easier technical and warranty support. You can also receive updates on new Hypertherm products and a free gift as a token of our appreciation.

For your records

Serial number: _____

Purchase date: _____

Distributor: _____

Maintenance notes:

HyPerformance Plasma
HPR800XD Auto Gas

Instruction Manual

(P/N 806500)

Revision 5 – May, 2025

Hypertherm, Inc.
Hanover, NH USA
www.hypertherm.com

© 2018 – 2025 Hypertherm, Inc.
All Rights Reserved

Hypertherm, HyPerformance, HyDefinition, LongLife and CommandTHC are trademarks of Hypertherm, Inc. and may be registered in the United States and/or other countries.

Hypertherm, Inc.

21 Great Hollow Road, P.O. Box 5010
Hanover, NH 03755 USA

603-643-3441 Tel (Main Office)

603-643-5352 Fax (All Departments)

info@hypertherm.com (Main Office)

800-643-9878 Tel (Technical Service)

technical.service@hypertherm.com (Technical Service)

800-737-2978 Tel (Customer Service)

customer.service@hypertherm.com (Customer Service)

Hypertherm México, S.A. de C.V.

52 55 5681 8109 Tel

52 55 5681 7978 Tel

soporte.tecnico@hypertherm.com (Technical Service)

Hypertherm Plasmatechnik GmbH

Sophie-Scholl-Platz 5

63452 Hanau

Germany

00 800 33 24 97 37 Tel

00 800 49 73 73 29 Fax

31 (0) 165 596900 Tel (Technical Service)

00 800 4973 7843 Tel (Technical Service)

technicalservice.emeia@hypertherm.com (Technical Service)

Hypertherm (Singapore) Pte Ltd.

Solaris @ Kallang 164

164 Kallang Way #03-13

Singapore 349248, Republic of Singapore

65 6841 2489 Tel

65 6841 2490 Fax

marketing.asia@hypertherm.com (Marketing)

techsupportapac@hypertherm.com (Technical Service)

Hypertherm Japan Ltd.

Level 9, Edobori Center Building

2-1-1 Edobori, Nishi-ku

Osaka 550-0002 Japan

81 6 6225 1183 Tel

81 6 6225 1184 Fax

htjapan.info@hypertherm.com (Main Office)

techsupportapac@hypertherm.com (Technical Service)

Hypertherm Europe B.V.

Laan van Kopenhagen 100

3317 DM Dordrecht

Nederland

31 165 596907 Tel

31 165 596901 Fax

31 165 596908 Tel (Marketing)

31 (0) 165 596900 Tel (Technical Service)

00 800 4973 7843 Tel (Technical Service)

technicalservice.emeia@hypertherm.com (Technical Service)

Hypertherm (Shanghai) Trading Co., Ltd.

B301, 495 ShangZhong Road

Shanghai, 200231

PR China

86-21-80231122 Tel

86-21-80231120 Fax

86-21-80231128 Tel (Technical Service)

techsupport.china@hypertherm.com (Technical Service)

South America & Central America: Hypertherm Brasil Ltda.

55 11 5116-8015 Tel

tecnico.sa@hypertherm.com (Technical Service)

Hypertherm Korea Branch

#3904. APEC-ro 17. Heaundae-gu. Busan.

Korea 48060

82 (0)51 747 0358 Tel

82 (0)51 701 0358 Fax

marketing.korea@hypertherm.com (Marketing)

techsupportapac@hypertherm.com (Technical Service)

Hypertherm Pty. Limited

Level 57, 25 Martin Place

Sydney, New South Wales, 2000.

+61 (02) 9238 2138 Tel

www.hyperthermassociates.com

Hypertherm (India) Thermal Cutting Pvt. Ltd

A-18 / B-1 Extension,

Mohan Co-Operative Industrial Estate,

Mathura Road, New Delhi 110044, India

91-11-40521201/ 2/ 3 Tel

91-11 40521204 Fax

htindia.info@hypertherm.com (Main Office)

technicalservice.emeia@hypertherm.com (Technical Service)

ELECTROMAGNETIC COMPATIBILITY (EMC)

Introduction

Hypertherm's CE-marked equipment is built in compliance with standard EN60974-10. The equipment should be installed and used in accordance with the information below to achieve electromagnetic compatibility.

The limits required by EN60974-10 may not be adequate to completely eliminate interference when the affected equipment is in close proximity or has a high degree of sensitivity. In such cases it may be necessary to use other measures to further reduce interference.

This cutting equipment is designed for use only in an industrial environment.

Installation and use

The user is responsible for installing and using the plasma equipment according to the manufacturer's instructions.

If electromagnetic disturbances are detected then it shall be the responsibility of the user to resolve the situation with the technical assistance of the manufacturer. In some cases this remedial action may be as simple as earthing the cutting circuit, see *Earthing of the workpiece*. In other cases, it could involve constructing an electromagnetic screen enclosing the power source and the work complete with associated input filters. In all cases, electromagnetic disturbances must be reduced to the point where they are no longer troublesome.

Assessment of area

Before installing the equipment, the user shall make an assessment of potential electromagnetic problems in the surrounding area. The following shall be taken into account:

- a. Other supply cables, control cables, signaling and telephone cables; above, below and adjacent to the cutting equipment.
- b. Radio and television transmitters and receivers.
- c. Computer and other control equipment.
- d. Safety critical equipment, for example guarding of industrial equipment.
- e. Health of the people around, for example the use of pacemakers and hearing aids.
- f. Equipment used for calibration or measurement.
- g. Immunity of other equipment in the environment. User shall ensure that other equipment being used in the environment is compatible. This may require additional protection measures.
- h. Time of day that cutting or other activities are to be carried out.

The size of the surrounding area to be considered will depend on the structure of the building and other activities that are taking place. The surrounding area may extend beyond the boundaries of the premises.

Methods of reducing emissions

Mains supply

Cutting equipment must be connected to the mains supply according to the manufacturer's recommendations. If interference occurs, it may be necessary to take additional precautions such as filtering of the mains supply.

Consideration should be given to shielding the supply cable of permanently installed cutting equipment, in metallic conduit or equivalent. Shielding should be electrically continuous throughout its length. The shielding should be connected to the cutting mains supply so that good electrical contact is maintained between the conduit and the cutting power source enclosure.

Maintenance of cutting equipment

The cutting equipment must be routinely maintained according to the manufacturer's recommendations. All access and service doors and covers should be closed and properly fastened when the cutting equipment is in operation. The cutting equipment should not be modified in any way, except as set forth in and in accordance with the manufacturer's written instructions. For example, the spark gaps of arc striking and stabilizing devices should be adjusted and maintained according to the manufacturer's recommendations.

Cutting cables

The cutting cables should be kept as short as possible and should be positioned close together, running at or close to the floor level.

Equipotential bonding

Bonding of all metallic components in the cutting installation and adjacent to it should be considered.

However, metallic components bonded to the workpiece will increase the risk that the operator could receive a shock by touching these metallic components and the electrode (nozzle for laser heads) at the same time.

The operator should be insulated from all such bonded metallic components.

Electromagnetic Compatibility (EMC)

Earthing of the workpiece

Where the workpiece is not bonded to earth for electrical safety, nor connected to earth because of its size and position, for example, ship's hull or building steel work, a connection bonding the workpiece to earth may reduce emissions in some, but not all instances. Care should be taken to prevent the earthing of the workpiece increasing the risk of injury to users, or damage to other electrical equipment. Where necessary, the connection of the workpiece to earth should be made by a direct connection to the workpiece, but in some countries where direct connection is not permitted, the bonding should be achieved by suitable capacitances selected according to national regulations.

Note: The cutting circuit may or may not be earthed for safety reasons. Changing the earthing arrangements should only be authorized by a person who is competent to assess whether the changes will increase the risk of injury, for example, by allowing parallel cutting current return paths which may damage the earth circuits of other equipment. Further guidance is provided in IEC 60974-9, Arc Welding Equipment, Part 9: Installation and Use.

Screening and shielding

Selective screening and shielding of other cables and equipment in the surrounding area may alleviate problems of interference. Screening of the entire plasma cutting installation may be considered for special applications.

Attention

Genuine Hypertherm parts are the factory-recommended replacement parts for your Hypertherm system. Any damage or injury caused by the use of other than genuine Hypertherm parts may not be covered by the Hypertherm warranty, and will constitute misuse of the Hypertherm Product.

You are solely responsible for the safe use of the Product. Hypertherm does not and cannot make any guarantee or warranty regarding the safe use of the product in your environment.

General

Hypertherm, Inc. warrants that its Products shall be free from defects in materials and workmanship for the specific periods of time set forth herein and as follows: if Hypertherm is notified of a defect (i) with respect to the plasma power supply within a period of two (2) years from the date of its delivery to you, with the exception of Powermax brand power supplies, which shall be within a period of three (3) years from the date of delivery to you, and (ii) with respect to the torch and leads within a period of one (1) year from its date of delivery to you, with the exception of the HPRXD short torch with integrated lead, which shall be within a period of six (6) months from the date of delivery to you, and with respect to torch lifter assemblies within a period of one (1) year from its date of delivery to you, and with respect to Automation products one (1) year from its date of delivery to you, with the exception of the EDGE Connect CNC, EDGE Connect T CNC, EDGE Connect TC CNC, EDGE Pro CNC, EDGE Pro Ti CNC, MicroEDGE Pro CNC, and ArcGlide THC, which shall be within a period of two (2) years from the date of delivery to you, and (iii) with respect to HyIntensity fiber laser components within a period of two (2) years from the date of its delivery to you, with the exception of laser heads and beam delivery cables, which shall be within a period of one (1) year from its date of delivery to you.

All third-party engines, engine accessories, alternators, and alternator accessories are covered by the respective manufacturers' warranties and not covered by this warranty.

This warranty shall not apply to any Powermax brand power supplies that have been used with phase converters. In addition, Hypertherm does not warranty systems that have been damaged as a result of poor power quality, whether from phase converters or incoming line power. This warranty shall not apply to any product which has been incorrectly installed, modified, or otherwise damaged.

Hypertherm provides repair, replacement or adjustment of the Product as the sole and exclusive remedy, if and only if the warranty set forth herein properly is invoked and applies. Hypertherm, at its sole option, shall repair, replace, or adjust, free of charge, any defective Products covered by this warranty which shall be returned with Hypertherm's prior authorization (which shall not be unreasonably withheld), properly packed, to Hypertherm's place of business in Hanover, New Hampshire, or to an authorized Hypertherm repair facility, all costs, insurance and freight pre paid by the customer. Hypertherm shall not be liable for any repairs, replacement, or adjustments of Products covered by this warranty, except those made pursuant to this paragraph and with Hypertherm's prior written consent.

The warranty set forth above is exclusive and is in lieu of all other warranties, express, implied, statutory, or otherwise with respect to the Products or as to the results which may be obtained therefrom, and all implied warranties or conditions of quality or of merchantability or fitness for a particular purpose or against infringement. The foregoing shall constitute the sole and exclusive remedy for any breach by Hypertherm of its warranty.

Distributors/OEMs may offer different or additional warranties, but Distributors/OEMs are not authorized to give any additional warranty protection to you or make any representation to you purporting to be binding upon Hypertherm.

Patent indemnity

Except only in cases of products not manufactured by Hypertherm or manufactured by a person other than Hypertherm not in strict conformity with Hypertherm's specifications and in cases of designs, processes, formulae, or combinations not developed or purported to be developed by Hypertherm, Hypertherm will have the right to defend or settle, at its own expense, any suit or proceeding brought against you alleging that the use of the Hypertherm product, alone and not in combination with any other product not supplied by Hypertherm, infringes any patent of any third party. You shall notify Hypertherm promptly upon learning of any action or threatened action in connection with any such alleged infringement (and in any event no longer than fourteen (14) days after learning of any action or threat of action), and Hypertherm's obligation to defend shall be conditioned upon Hypertherm's sole control of, and the indemnified party's cooperation and assistance in, the defense of the claim.

Limitation of liability

In no event shall Hypertherm be liable to any person or entity for any incidental, consequential direct, indirect, punitive or exemplary damages (including but not limited to lost profits) regardless of whether such liability is based on breach of contract, tort, strict liability, breach of warranty, failure of essential purpose, or otherwise, and even if advised of the possibility of such damages. Hypertherm shall not be liable for any losses to Distributor based on down time, lost production or lost profits. It is the intention of the Distributor and Hypertherm that this provision be construed by a court as being the broadest limitation of liability consistent with applicable law.

National and local codes

National and local codes governing plumbing and electrical installation shall take precedence over any instructions contained in this manual. In no event shall Hypertherm be liable for injury to persons or property damage by reason of any code violation or poor work practices.

Warranty

Liability cap

In no event shall Hypertherm's liability, if any, whether such liability is based on breach of contract, tort, strict liability, breach of warranties, failure of essential purpose or otherwise, for any claim, action, suit or proceeding (whether in court, arbitration, regulatory proceeding or otherwise) arising out of or relating to the use of the Products exceed in the aggregate the amount paid for the Products that gave rise to such claim.

Insurance

At all times you will have and maintain insurance in such quantities and types, and with coverage sufficient and appropriate to defend and to hold Hypertherm harmless in the event of any cause of action arising from the use of the products.

Transfer of rights

You may transfer any remaining rights you may have hereunder only in connection with the sale of all or substantially all of your assets or capital stock to a successor in interest who agrees to be bound by all of the terms and conditions of this Warranty. Within thirty (30) days before any such transfer occurs, you agree to notify in writing Hypertherm, which reserves the right of approval. Should you fail timely to notify Hypertherm and seek its approval as set forth herein, the Warranty set forth herein shall be null and void and you will have no further recourse against Hypertherm under the Warranty or otherwise.

Waterjet product warranty coverage

Product	Parts coverage
HyPrecision pumps	27 months from the ship date, or 24 months from the date of proven installation, or 4,000 hours, whichever occurs first
PowerDredge abrasive removal system	15 months from the ship date or 12 months from the date of proven installation, whichever occurs first
EcoSift abrasive recycling system	15 months from the ship date or 12 months from the date of proven installation, whichever occurs first
Abrasive metering devices	15 months from the ship date or 12 months from the date of proven installation, whichever occurs first
On/off valve air actuators	15 months from the ship date or 12 months from the date of proven installation, whichever occurs first
Diamond orifices	600 hours of use with the use of a thimble filter and compliance with Hypertherm's water quality requirements

Consumable parts are not covered by this warranty. Consumable parts include, but are not limited to, high-pressure water seals, check valves, cylinders, bleed-down valves, low-pressure seals, high-pressure tubing, low- and high-pressure water filters and abrasive collection bags. All third-party pumps, pump accessories, hoppers, hopper accessories, dryer boxes, dryer box accessories and plumbing accessories are covered by the respective manufacturers' warranties and not covered by this warranty.

ELECTROMAGNETIC COMPATIBILITY (EMC)EMC-1
WARRANTY W-1

Section 1

SAFETY 1
 Recognize safety information2
 Follow safety instructions.....2
 Responsibility for safety.....2
 A plasma arc can damage frozen pipes2
 Static electricity can damage circuit boards2
 Inspect equipment before using.....2
 Electrical hazards.....3
 Grounding safety.....3
 Electric shock can kill.....3
 Cutting can cause fire or explosion4
 Machine motion can cause injury4
 Compressed gas equipment safety.....5
 Toxic fumes can cause injury or death.....5
 Gas cylinders can explode if damaged.....5
 A plasma arc can cause injury and burns.....6
 Arc rays can burn eyes and skin.....6
 Pacemaker and hearing aid operation6
 Dry dust collection information7
 Noise can damage hearing.....7
 Laser radiation8
 Additional safety information8

Section 2

SPECIFICATIONS2-1
 System description.....2-3
 General2-3
 Power supplies2-3
 Chiller2-3
 Chiller interface console2-3
 Ignition console.....2-3
 Selection console.....2-3
 Metering console.....2-3
 Torch2-3
 Specifications2-4
 System gas requirements.....2-4
 Power supplies2-5
 Ecodesign requirements for CE models.....2-6
 Critical raw materials2-6
 China Energy Label.....2-7
 Chiller2-8
 Chiller interface console – 078537.....2-9
 Ignition console – 078536.....2-10

TABLE OF CONTENTS

Torch lead junction box (Optional) – 078619	2-12
Selection console – 078533.....	2-13
Metering console – 078535.....	2-14
Torch – 228599	2-15
IEC symbols	2-16
Symbols and Marks.....	2-17
Section 3	
INSTALLATION	3-1
Upon receipt	3-3
Claims.....	3-3
Installation requirements.....	3-3
Noise levels	3-3
Placement of system components.....	3-3
Installation requirements.....	3-4
System components.....	3-5
Cables and hoses	3-5
Customer-supplied power cables.....	3-5
Supply gas hoses.....	3-5
Recommended grounding and shielding practices	3-6
Introduction	3-6
Types of grounding	3-6
Grounding practices.....	3-6
Grounding diagram.....	3-9
Placement of the primary power supply	3-11
Placement of the secondary power supply.....	3-12
Lifting the power supply.....	3-13
Install the ignition console.....	3-15
Placement of the chiller	3-17
Install the chiller interface console.....	3-18
Install the metering console.....	3-19
Placement of the selection console.....	3-20
Primary power supply to secondary power supply cables.....	3-21
Interface (on/off) cable.....	3-21
Communication cable.....	3-22
Power supply to ignition console leads	3-23
Pilot arc lead.....	3-23
Negative leads.....	3-23
Ignition console power cable (from primary power supply).....	3-25
Coolant hose set (chiller to chiller-interface console).....	3-26
Coolant hose set (chiller-interface console to ignition console).....	3-27
Primary power supply to chiller interface console.....	3-28
Chiller interface power cable.....	3-28
Secondary power supply to chiller interface console.....	3-29
Chiller interface communication cable	3-29
Primary Power supply to selection console cables.....	3-30
Selection console communication cable	3-30

Selection console power cable.....	3-30
Selection console to metering console hose and lead assembly.....	3-32
Cable and gas hose assembly	3-32
Power supply to CNC interface cable.....	3-34
Optional multi-system CNC interface cable	3-34
Examples of output circuits	3-36
Examples of input circuits.....	3-37
Remote ON/OFF switch (provided by customer)	3-38
Torch lead assembly	3-39
Torch lead junction box (Optional).....	3-40
Install the junction box.....	3-41
Connect the leads.....	3-42
Work lead	3-46
Torch connections	3-47
Connect the torch to the torch lead assembly	3-47
Connect the torch to the quick-disconnect	3-51
Torch mounting and alignment	3-52
Mounting the torch.....	3-52
Torch alignment	3-52
Torch lifter requirement	3-53
HyperNet.....	3-53
Power requirements (for each power supply).....	3-54
General	3-54
Line disconnect switch	3-55
Main power cable (power supplies)	3-55
Main power cable (chiller).....	3-55
Connect the power.....	3-56
Torch coolant requirements.....	3-57
Premixed coolant for standard operating temperatures	3-57
Custom Coolant mix for cold operating temperatures.....	3-58
Custom Coolant mix for hot operating temperatures.....	3-59
Water purity requirements	3-59
Fill the chiller with coolant.....	3-60
Gas requirements	3-61
Setting the supply regulators.....	3-61
Gas regulators.....	3-62
Supply gas plumbing	3-63
Connect the supply gases	3-64
Supply gas hoses	3-65
Section 4	
OPERATION	4-1
Daily start-up.....	4-3
Check torch	4-3
Power indicators	4-4
General	4-4

TABLE OF CONTENTS

Power supply.....	4-4
Selection console.....	4-4
Chiller interface console.....	4-4
Metering console.....	4-4
CNC controller requirements.....	4-5
CNC screen examples.....	4-6
Main (control) screen.....	4-6
Diagnostic screen.....	4-7
Test screen.....	4-8
Cut chart screen.....	4-9
Consumable selection.....	4-10
Standard cutting (0°).....	4-10
Bevel cutting (0° to 45°).....	4-10
PowerPierce technology.....	4-10
Marking.....	4-10
Consumables for mirror-image cutting.....	4-10
SilverPlus electrodes.....	4-10
Mild steel.....	4-11
Stainless steel.....	4-12
Aluminum.....	4-13
Mild steel bevel cutting.....	4-14
Mild steel, thick piercing, bevel cutting.....	4-14
Stainless steel bevel cutting.....	4-15
Install and Inspect consumables.....	4-16
Torch maintenance.....	4-20
Routine maintenance.....	4-20
Quick-disconnect maintenance.....	4-20
Maintenance kit.....	4-20
Torch connections.....	4-21
Replace torch water tube.....	4-21
Common cutting faults.....	4-22
How to optimize cut quality.....	4-23
Tips for table and torch.....	4-23
Plasma set-up tips.....	4-23
Maximize the life of consumable parts.....	4-23
Additional factors of cut quality.....	4-24
Additional improvements.....	4-26
Cut charts.....	4-27
Thin stainless steel with HDi technology.....	4-27
Overview.....	4-27
Thick stainless steel piercing technique.....	4-28
Overview.....	4-28
Fine Feature cutting.....	4-30
Overview.....	4-30
Recommendations.....	4-30
Bevel cutting.....	4-31

Consumables	4-31
Bevel compensation tables	4-31
Bevel cutting definitions	4-32
Cutting thick material	4-33
Underwater cut charts	4-34
Overview.....	4-34
Estimated kerf-width compensation	4-36

Section 5

MAINTENANCE.....	5-1
Introduction	5-3
Routine maintenance.....	5-3
System description.....	5-4
Power and signal cables.....	5-4
Sequence of operation	5-5
Gas system purge cycle.....	5-6
Gas system valve usage.....	5-6
Marking process	5-8
Power supply troubleshooting	5-9
Error codes.....	5-10
Error code troubleshooting – error codes 000 to 018	5-11
Error code troubleshooting – error codes 020 to 028, 224 to 228.....	5-12
Error code troubleshooting – error codes 030 to 042, 231 to 234.....	5-13
Error code troubleshooting – error codes 044 to 046	5-14
Error code troubleshooting – error codes 047 to 053, 248 to 250.....	5-15
Error code troubleshooting – error codes 054 to 061	5-16
Error code troubleshooting – error codes 062 to 067, 265 to 267.....	5-17
Error code troubleshooting – error codes 071 to 075, 273 to 275.....	5-18
Error code troubleshooting – error codes 076 to 101, 276 to 301.....	5-19
Error code troubleshooting – error codes 102 to 111, 302 to 308.....	5-20
Error code troubleshooting – error codes 116 to 133, 316.....	5-21
Error code troubleshooting – error codes 134 to 140, 334 and 338.....	5-22
Error code troubleshooting – error codes 141 to 152, 346 to 351	5-23
Error code troubleshooting – error codes 153 to 156, 354 to 356.....	5-24
Error code troubleshooting – error codes 157 to 159, 357 to 359.....	5-25
Error code troubleshooting – error codes 160 to 180	5-26
Error code troubleshooting – error code 181, 182, 298, and 383.....	5-27
Power supply states.....	5-28
Plasma system operation with pump time-out.....	5-29
CNC operation with pump time-out.....	5-30
Initial checks.....	5-31
Power measurement	5-32
Air filter element replacement	5-33
Coolant system servicing	5-34
Draining the coolant system.....	5-34
Chiller interface coolant filter	5-36

TABLE OF CONTENTS

Filter replacement.....	5-36
Gas leak tests.....	5-37
Leak test 1 (inlet leak test).....	5-37
Leak test 2 (system leak test).....	5-38
Leak test 3 (proportional valve test in the metering console).....	5-38
Power supply control board PCB3.....	5-39
Power supply power distribution board PCB2.....	5-40
Start-circuit PCB1.....	5-41
Operation.....	5-41
Start circuit functional schematic.....	5-41
Start circuit troubleshooting.....	5-41
Pilot arc current levels.....	5-43
Pilot arc relay wiring.....	5-43
Pump motor drive board PCB7.....	5-44
Chiller interface power distribution board PCB1.....	5-45
Coolant sensor board PCB2.....	5-46
Selection console control board PCB2.....	5-47
Selection console power distribution board PCB1.....	5-48
Selection console, AC valve-driver board PCB3.....	5-49
Metering console control board PCB2.....	5-50
Metering console power distribution board PCB1.....	5-51
Chopper tests.....	5-52
Phase-loss detection test.....	5-54
Test continuity between the nozzle and workpiece.....	5-55
Preventive maintenance.....	5-56
Section 6	
PARTS LIST.....	6-1
Power supply.....	6-2
Chiller.....	6-6
Chiller interface console.....	6-7
Ignition console.....	6-8
Torch lead junction box (Optional).....	6-9
Ignition console to junction box leads.....	6-10
Metering console.....	6-13
HyPerformance torch.....	6-14
Torch assembly.....	6-14
Torch leads.....	6-15
Ohmic contact wire.....	6-15
Consumable parts kits.....	6-16
Consumable parts kits.....	6-18
Consumables for mirror-image cutting.....	6-19

Straight cutting 6-19
 Bevel cutting..... 6-21
 Recommended spare parts 6-23
 Warning Label – 110647..... 6-26

Section 7

WIRING DIAGRAMS.....7-1

Introduction 7-1
 Wiring diagram symbols..... 7-1
 Discrete output functionality..... 7-4

Appendix A

HYPER THERM TORCH COOLANT SAFETY DATAA-1

1 – Identification of the substance/mixture and of the company undertaking a-2
 2 – Hazards identification a-2
 3 – Composition/information on ingredients..... a-3
 4 – First aid measures a-3
 5 – Fire-fighting measures..... a-3
 6 – Accidental release measures..... a-3
 7 – Handling and storage a-4
 8 – Exposure controls/personal protection a-4
 9 – Physical and chemical properties a-4
 10 – Stability and reactivity a-5
 11 – Toxicological information..... a-5
 12 – Ecological information..... a-5
 13 – Disposal considerations a-6
 14 – Transport information a-6
 15 – Regulatory information..... a-6
 16 – Other information a-7
 Freezing Point of Propylene Glycol Solution a-8

Appendix B

CNC INTERFACE PROTOCOL.....B-1

Interface hardware b-2
 Signal list..... b-2
 Signals b-2
 Hardware b-3
 Multi-drop wiring..... b-4
 Multi-drop addressing b-5
 Serial commands b-5
 Format b-5
 Framing b-5
 Commands..... b-5
 Command table (1 of 14) b-6
 Error responses b-20
 Calculating checksums..... b-20
 Error codes..... b-21

TABLE OF CONTENTS

Status codes.....	b-25
Gas type codes.....	b-25
CNC requirements	b-26
Auto gas console.....	b-26
Serial interface guidelines.....	b-27
Checksum	b-27
Message retries	b-27
Cable shielding	b-27

Appendix C

ROBOTIC APPLICATIONS..... C-1

Components for robotic applications.....	c-2
Torch leads	c-2
Ohmic contact extension.....	c-2
Rotational mounting sleeve (optional) – 220864	c-3
Leather over wrap – 024866	c-3
Robotic teaching torch (laser pointer) – 228394.....	c-3
Torch and rotational mounting sleeve dimensions.....	c-3
Rotational mounting sleeve clamp dimensions.....	c-4

Section 1

SAFETY

In this section:

Recognize safety information	2
Follow safety instructions.....	2
Responsibility for safety.....	2
A plasma arc can damage frozen pipes	2
Static electricity can damage circuit boards	2
Inspect equipment before using.....	2
Electrical hazards.....	3
Grounding safety	3
Electric shock can kill.....	3
Cutting can cause fire or explosion	4
Machine motion can cause injury	4
Compressed gas equipment safety.....	5
Toxic fumes can cause injury or death	5
Gas cylinders can explode if damaged.....	5
A plasma arc can cause injury and burns.....	6
Arc rays can burn eyes and skin.....	6
Pacemaker and hearing aid operation	6
Dry dust collection information	7
Noise can damage hearing.....	7
Laser radiation	8
Additional safety information	8



RECOGNIZE SAFETY INFORMATION

The symbols shown in this section are used to identify potential hazards. When you see a safety symbol in this manual or on your machine, understand the potential for personal injury, and follow the related instructions to avoid the hazard.



FOLLOW SAFETY INSTRUCTIONS

Carefully read all safety messages in this manual and safety labels on your machine.

- Keep the safety labels on your machine in good condition. Replace missing or damaged labels immediately.
- Learn how to operate the machine and how to use the controls properly. Do not let anyone operate it without instruction.
- Keep your machine in proper working condition. Unauthorized modifications to the machine may affect safety and machine service life.

DANGER WARNING CAUTION

American National Standards Institute (ANSI) guidelines are used for safety signal words and symbols. The signal word DANGER or WARNING is used with a safety symbol. DANGER identifies the most serious hazards.

- DANGER and WARNING safety labels are located on your machine near specific hazards.
- DANGER safety messages precede related instructions in the manual that will result in serious injury or death if not followed correctly.
- WARNING safety messages precede related instructions in this manual that may result in injury or death if not followed correctly.
- CAUTION safety messages precede related instructions in this manual that may result in minor injury or damage to equipment if not followed correctly.

INSPECT EQUIPMENT BEFORE USING

All cutting equipment must be inspected as required to make sure it is in safe operating condition. When found to be incapable of reliable and safe operation, the equipment must be repaired by qualified personnel prior to its next use or withdrawn from service.

RESPONSIBILITY FOR SAFETY

The person or entity responsible for the safety of the workplace must:

- Make sure that operators and their supervisors are trained in the safe use of their equipment, the safe use of the process, and emergency procedures.
- Make sure that all hazards and safety precautions identified herein are communicated to and understood by workers before the start of work.
- Designate approved cutting areas and establish procedures for safe cutting.
- Be responsible for authorizing cutting operations in areas not specifically designed or approved for such processes.
- Make sure that only approved equipment, such as torches and personal protective equipment, are used.
- Select contractors who provide trained and qualified personnel, and who have awareness of the risks involved, to do cutting.
- Tell contractors about flammable materials or hazardous conditions that are specific to the site, or hazardous conditions that they may not be aware of.
- Make sure that the quality and quantity of air for ventilation is such that personnel exposures to hazardous contaminants are below the allowable limits.
- Make sure that ventilation in confined spaces is sufficient to allow adequate oxygen for life support, to prevent accumulation of asphyxiants or flammable explosive mixtures, to prevent oxygen-enriched atmospheres, and to keep airborne contaminants in breathing atmospheres below allowable limits.

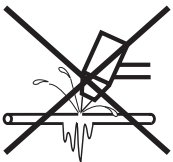

A PLASMA ARC CAN DAMAGE FROZEN PIPES

Frozen pipes may be damaged or can burst if you attempt to thaw them with a plasma torch.



STATIC ELECTRICITY CAN DAMAGE CIRCUIT BOARDS

Use proper precautions when handling printed circuit boards:

- Store PC boards in anti-static containers.
- Wear a grounded wrist strap when handling PC boards.



GROUNDING SAFETY

Work cable Attach the work cable securely to the workpiece or the work table with good metal-to-metal contact. Do not connect it to the piece that will fall away when the cut is complete.

Work table Connect the work table to an earth ground, in accordance with appropriate national and local electrical codes.

Input power

- Be sure to connect the power cord ground wire to the ground in the disconnect box.

- If installation of the plasma system involves connecting the power cord to the power supply, be sure to connect the power cord ground wire properly.
- Place the power cord's ground wire on the stud first, then place any other ground wires on top of the power cord ground. Fasten the retaining nut tightly.
- Tighten all electrical connections to avoid excessive heating.

ELECTRICAL HAZARDS

- Only trained and authorized personnel may open this equipment.
- If the equipment is permanently connected, turn it off, and lock out/tag out power before the enclosure is opened.
- If power is supplied to the equipment with a cord, unplug the unit before the enclosure is opened.
- Lockable disconnects or lockable plug covers must be provided by others.
- Wait 5 minutes after removal of power before entering the enclosure to allow stored energy to discharge.
- If the equipment must have power when the enclosure is open for servicing, arc flash explosion hazards may exist. Follow **all** local requirements (NFPA 70E in the USA) for safe work practices and for personal protective equipment when servicing energized equipment.
- Prior to operating the equipment after moving, opening, or servicing, make sure to close the enclosure and make sure that there is proper earth ground continuity to the enclosure.
- Always follow these instructions for disconnecting power before inspecting or changing torch consumable parts.



ELECTRIC SHOCK CAN KILL

Touching live electrical parts can cause a fatal shock or severe burn.

- Operating the plasma system completes an electrical circuit between the torch and the workpiece. The workpiece and anything touching the workpiece are part of the electrical circuit.
- In machine torch applications, never touch the torch body, workpiece or the water in a water table when the plasma system is operating.

Electric shock prevention

All Hypertherm plasma systems use high voltage in the cutting process (200 to 400 VDC are common). Take the following precautions when operating this system:

- Wear insulated gloves and boots, and keep your body and clothing dry.
- Do not stand, sit or lie on – or touch – any wet surface when using the plasma system.
- Insulate yourself from work and ground using dry insulating mats or covers big enough to prevent any physical contact with the work or ground. If you must work in or near a damp area, use extreme caution.
- Provide a disconnect switch close to the power supply with properly sized fuses. This switch allows the operator to turn off the power supply quickly in an emergency situation.
- When using a water table, be sure that it is correctly connected to earth ground

- Install and ground this equipment according to the instruction manual and in accordance with national and local regulations.
- Inspect the input power cord frequently for damage or cracking of the cover. Replace a damaged power cord immediately. **Bare wiring can kill.**
- Inspect and replace any worn or damaged torch leads.
- Do not pick up the workpiece, including the waste cutoff, while you cut. Leave the workpiece in place or on the workbench with the work lead attached during the cutting process.
- Before checking, cleaning, or changing torch parts, disconnect the main power or unplug the power supply.
- Never bypass or shortcut the safety interlocks.
- Before removing any power supply or system enclosure cover, disconnect electrical input power. Wait 5 minutes after disconnecting the main power to allow capacitors to discharge.
- Never operate the plasma system unless the power supply covers are in place. Exposed power supply connections present a severe electrical hazard.
- When making input connections, attach a proper grounding conductor first.
- Each plasma system is designed to be used only with specific torches. Do not substitute other torches, which could overheat and present a safety hazard.



CUTTING CAN CAUSE FIRE OR EXPLOSION

Fire prevention

- Make sure the cutting area is safe before doing any cutting. Keep a fire extinguisher nearby.
- Remove all flammables within 35 feet (10 m) of the cutting area.
- Quench hot metal or allow it to cool before handling or before letting it touch combustible materials.
- Never cut containers with potentially flammable materials inside – they must be emptied and properly cleaned first.
- Ventilate potentially flammable atmospheres before cutting.
- When cutting with oxygen as the plasma gas, an exhaust ventilation system is required.

Explosion prevention

- Do not use the plasma system if explosive dust or vapors may be present.
- Do not cut pressurized cylinders, pipes, or any closed containers.
- Do not cut containers that have held combustible materials.



WARNING
Explosion Hazard
Argon-Hydrogen and Methane

Hydrogen and methane are flammable gases that present an explosion hazard. Keep flames away from cylinders and hoses that contain methane or hydrogen mixtures. Keep flames and sparks away from the torch when using methane or argon-hydrogen plasma.



WARNING
Underwater Cutting with Fuel Gases Containing Hydrogen

- Do not cut underwater with fuel gases containing hydrogen.
- Cutting underwater with fuel gases containing hydrogen can result in an explosive condition that can detonate during plasma cutting operations.



WARNING
Explosion Hazard
Hydrogen Detonation with Aluminum Cutting



When you use a plasma torch to cut aluminum alloys under water or on a water table, a chemical reaction between the water and the workpiece, parts, fine particles, or molten aluminum droplets generates significantly more hydrogen gas than occurs with other metals. This hydrogen gas may get trapped under the workpiece. If exposed to oxygen or air, the plasma arc or a spark from any source can ignite this trapped hydrogen gas, causing an explosion that may result in death, personal injury, loss of property, or equipment damage.

Consult with the table manufacturer and other experts prior to cutting aluminum to implement a risk assessment and mitigation plan that eliminates the risk of detonation by preventing hydrogen accumulation.

Also, make sure that the water table, fume extraction (ventilation), and other parts of the cutting system have been designed with aluminum cutting in mind.

Do not cut aluminum alloys underwater or on a water table unless you can prevent the accumulation of hydrogen gas.

Note: With proper mitigation, most aluminum alloys can be plasma cut on a water table. An exception is aluminum-lithium alloys. **Never cut aluminum-lithium alloys in the presence of water.** Contact your aluminum supplier for additional safety information regarding hazards associated with aluminum-lithium alloys.

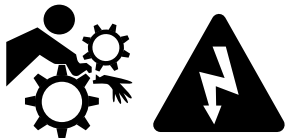

MACHINE MOTION CAN CAUSE INJURY

When an original equipment manufacturer (OEM) makes a cutting system by combining Hypertherm equipment with other equipment, the end-use customer and the OEM are responsible for providing protection against the hazardous moving parts of this cutting system. However, we advise the following to prevent operator injury and equipment damage:

- Read and follow the instruction manual provided by the OEM.
- Maintain a restricted-access area larger than the maximum movement range of the cutting system's moving parts.
- Where there is a risk of collision, do not allow personnel or equipment near the cutting system's moving parts.
- Avoid accidental contact with the CNC touchscreen or joystick. Accidental contact can activate commands and result in unintended motion.
- Do not service or clean the machinery during operation.
- If servicing is required, enable the safety interlock or disconnect and lock out/tag out power to disable the motors and prevent motion.
- Allow only qualified personnel to operate, maintain, and service the machinery.

COMPRESSED GAS EQUIPMENT SAFETY

- Never lubricate cylinder valves or regulators with oil or grease.
- Use only correct gas cylinders, regulators, hoses, and fittings designed for the specific application.
- Maintain all compressed gas equipment and associated parts in good condition.
- Label and color-code all gas hoses to identify the type of gas in each hose. Consult applicable national and local regulations.



GAS CYLINDERS CAN EXPLODE IF DAMAGED

Gas cylinders contain gas under high pressure. If damaged, a cylinder can explode.

- Handle and use compressed gas cylinders in accordance with applicable national and local regulations.
- Handle and use compressed gas cylinders in accordance with applicable national and local regulations.
- Never use a cylinder that is not upright and secured in place.
- Keep the protective cap in place over the valve except when the cylinder is in use or connected for use.
- Never allow electrical contact between the plasma arc and a cylinder.
- Never expose cylinders to excessive heat, sparks, slag, or open flame.
- Never use a hammer, wrench, or other tool to open a stuck cylinder valve.



TOXIC FUMES CAN CAUSE INJURY OR DEATH

The plasma arc by itself is the heat source used for cutting. Accordingly, although the plasma arc has not been identified as a source of toxic fumes, the material being cut can be a source of toxic fumes or gases that deplete oxygen.

Fumes produced vary depending on the metal that is cut. Metals that may release toxic fumes include, but are not limited to, stainless steel, carbon steel, zinc (galvanized), and copper.

In some cases, the metal may be coated with a substance that could release toxic fumes. Toxic coatings include, but are not limited to, lead (in some paints), cadmium (in some paints and fillers), and beryllium.

Gases produced by plasma cutting vary based on the material to be cut and the method of cutting, but may include ozone, oxides of nitrogen, hexavalent chromium, hydrogen, and other substances if such are contained in or released by the material being cut.

Caution should be taken to minimize exposure to fumes produced by any industrial process. Depending upon the chemical composition and concentration of the fumes (as well as other factors, such as ventilation), there may be a risk of physical illness, such as birth defects or cancer.

It is the responsibility of the equipment and site owner to test the air quality in the area where the equipment is used and to ensure that the air quality in the workplace meets all local and national standards and regulations.

The air quality level in any relevant workplace depends on site-specific variables such as:

- Table design (wet, dry, underwater).
- Material composition, surface finish, and composition of coatings.
- Volume of material removed.
- Duration of cutting or gouging.
- Size, air volume, ventilation and filtration of the work area.
- Personal protective equipment.
- Number of welding and cutting systems in operation.
- Other site processes that may produce fumes.

If the workplace must conform to national or local regulations, only monitoring or testing done at the site can determine whether the site is above or below allowable levels.

To reduce the risk of exposure to fumes:

- Remove all coatings and solvents from the metal before cutting.
- Use local exhaust ventilation to remove fumes from the air.
- Do not inhale fumes. Wear an air-supplied respirator when cutting any metal coated with, containing, or suspected to contain toxic elements.
- Assure that those using welding or cutting equipment, as well as air-supplied respiration devices, are qualified and trained in the proper use of such equipment.
- Never cut containers with potentially toxic materials inside. Empty and properly clean the container first.
- Monitor or test the air quality at the site as needed.
- Consult with a local expert to implement a site plan to ensure safe air quality.

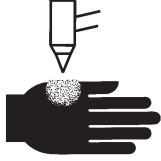

A PLASMA ARC CAN CAUSE INJURY AND BURNS

Instant-on torches

Plasma arc comes on immediately when the torch switch is activated.

The plasma arc will cut quickly through gloves and skin.

- Keep away from the torch tip.
- Do not hold metal near the cutting path.
- Never point the torch toward yourself or others.



ARC RAYS CAN BURN EYES AND SKIN

Eye protection Plasma arc rays produce intense visible and invisible (ultraviolet and infrared) rays that can burn eyes and skin.

- Use eye protection in accordance with applicable national and local regulations.
- Wear eye protection (safety glasses or goggles with side shields, and a welding helmet) with appropriate lens shading to protect your eyes from the arc's ultraviolet and infrared rays.

Skin protection Wear protective clothing to protect against burns caused by ultraviolet light, sparks, and hot metal.

- Wear gauntlet gloves, safety shoes, and hat.

- Wear flame-retardant clothing to cover all exposed areas.
- Wear cuffless trousers to prevent entry of sparks and slag.

Also, remove any combustibles, such as a butane lighter or matches, from your pockets before cutting.

Cutting area Prepare the cutting area to reduce reflection and transmission of ultraviolet light:

- Paint walls and other surfaces with dark colors to reduce reflection.
- Use protective screens or barriers to protect others from flash and glare.
- Warn others not to watch the arc. Use placards or signs.

Arc current	Minimum protective shade number (ANSI Z49.1:2012)	Suggested shade number for comfort (ANSI Z49.1:212)	OSHA 29CFR 1910.133(a)(5)	Europe EN168:2002
Less than 40 A	5	5	8	9
41 A to 60 A	6	6	8	9
61 A to 80 A	8	8	8	9
81 A to 125 A	8	9	8	9
126 A to 150 A	8	9	8	10
151 A to 175 A	8	9	8	11
176 A to 250 A	8	9	8	12
251 A to 300 A	8	9	8	13
301 A to 400 A	9	12	9	13
401 A to 800 A	10	14	10	N/A



PACEMAKER AND HEARING AID OPERATION

Pacemaker and hearing aid operation can be affected by magnetic fields from high currents.

Pacemaker and hearing aid wearers should consult a doctor before going near any plasma arc cutting and gouging operations.

To reduce magnetic field hazards:

- Keep both the work lead and the torch lead to one side, away from your body.
- Route the torch leads as close as possible to the work lead.
- Do not wrap or drape the torch lead or work lead around your body.
- Keep as far away from the power supply as possible.



NOISE CAN DAMAGE HEARING

Cutting with a plasma arc can exceed acceptable noise levels as defined by local regulations in many applications. Prolonged exposure to excessive noise can damage hearing. Always wear proper ear protection when cutting or gouging, unless sound pressure level measurements taken at the site have verified personal hearing protection is not necessary per relevant international, regional, and local regulations.

Significant noise reduction can be obtained by adding simple engineering controls to cutting tables such as barriers or curtains positioned between the plasma arc and the workstation, and/or locating the workstation away from the plasma arc. Implement

administrative controls in the workplace to restrict access and limit operator exposure time, and screen off noisy areas and/or take measures to reduce reverberation in cutting areas by putting up noise absorbers.

Use ear protectors if the noise is disruptive or if there is a risk of hearing damage after all other engineering and administrative controls have been implemented. If hearing protection is required, wear only approved personal protective equipment such as ear muffs or ear plugs with a noise reduction rating appropriate for the situation. Warn others near the cutting area of possible noise hazards. In addition, ear protection can prevent hot splatter from entering the ear.

DRY DUST COLLECTION INFORMATION

In some workplaces, dry dust can represent a potential explosion hazard.

The U.S. National Fire Protection Association's NFPA standard 68, "Explosion Protection by Deflagration Venting," provides requirements for the design, location, installation, maintenance, and use of devices and systems to vent combustion gases and pressures after any deflagration event. Consult with the manufacturer or installer of any dry dust collection system for applicable requirements before you install a new dry dust collection system or make significant changes in the process or materials used with an existing dry dust collection system.

Consult your local "Authority Having Jurisdiction" (AHJ) to determine whether any edition of NFPA standard 68 has been "adopted by reference" in your local building codes.

Refer to NFPA standard 68 for definitions and explanations of regulatory terms such as deflagration, AHJ, adopted by reference, the Kst value, deflagration index, and other terms.

Note 1 – Unless a site-specific evaluation has been completed that determines that none of the dust generated is combustible, then NFPA standard 68 requires the use of explosion vents. Design the explosion vent size and type to conform to the worst-case Kst value as described in Annex F of NFPA standard 68. NFPA standard 68 does not specifically identify plasma cutting or other thermal cutting processes as requiring deflagration venting systems, but it does apply these new requirements to all dry dust collection systems.

Note 2 – Users should consult and comply with all applicable national, state, and local regulations. Publications do not intend to urge action that is not in compliance with all applicable regulations and standards, and this manual may never be construed as doing so.

LASER RADIATION

Exposure to the laser output can result in serious eye injury. Avoid direct eye exposure.

For your convenience and safety, on Hypertherm products that use a laser, one of the following laser radiation labels has been applied on the product near where the laser beam exits the enclosure. The maximum output (mV), wavelength emitted (nM) and, if appropriate, the pulse duration is also provided.

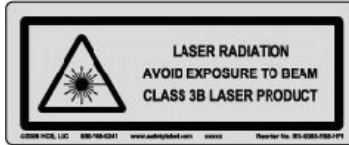

Additional laser safety instructions:

- Consult with an expert on local laser regulations. Laser safety training may be required.
- Do not allow untrained persons to operate the laser. Lasers can be dangerous in the hands of untrained users.
- Do not look into the laser aperture or beam at any time.
- Position the laser as instructed to avoid unintentional eye contact.
- Do not use the laser on reflective workpieces.
- Do not use optical tools to view or reflect the laser beam.
- Do not disassemble or remove the laser or aperture cover.
- Modifying the laser or product in any way can increase the risk of laser radiation.
- Use of adjustments or performance of procedures other than those specified in this manual may result in hazardous laser radiation exposure.
- Do not operate in explosive atmospheres, such as in the presence of flammable liquids, gases, or dust.
- Use only laser parts and accessories that are recommended or provided by the manufacturer for your model.
- Repairs and servicing **must** be performed by qualified personnel.
- Do not remove or deface the laser safety label.

ADDITIONAL SAFETY INFORMATION

1. ANSI Standard Z49.1, Safety in Welding and Cutting, American Welding Society, 550 LeJeune Road, P.O. Box 351020, Miami, FL 33135
2. ANSI Standard Z49.2, Fire Prevention in the Use of Cutting and Welding Processes, American National Standards Institute, 1430 Broadway, New York, NY 10018
3. ANSI Standard Z87.1, Safe Practices for Occupation and Educational Eye and Face Protection, American National Standards Institute, 1430 Broadway, New York, NY 10018
4. AWS F4.1, Recommended Safe Practices for the Preparation for Welding and Cutting of Containers and Piping That Have Held Hazardous Substances, American Welding Society, 550 LeJeune Road, P.O. Box 351040, Miami, FL 33135
5. AWS F5.2, Recommended Safe Practices for Plasma Arc Cutting, American Welding Society, 550 LeJeune Road, P.O. Box 351040, Miami, FL 33135
6. CGA Pamphlet P-1, Safe Handling of Compressed Gases in Cylinders, Compressed Gas Association, 1235 Jefferson Davis Highway, Arlington, VA 22202
7. CSA Standard W117.2, Code for Safety in Welding and Cutting, Canadian Standards Association Standard Sales, 178 Rexdale Boulevard, Rexdale, Ontario M9W 1R3, Canada
8. NFPA Standard 51B, Cutting and Welding Processes, National Fire Protection Association, 1 Batterymarch Park, Quincy, MA 02169-7471
9. NFPA Standard 70, National Electrical Code, National Fire Protection Association, 1 Batterymarch Park, Quincy, MA 02169-7471
10. OSHA, Safety and Health Standards, 29FR 1910 U.S. Government Printing Office, Washington, D.C. 20402
11. AWS Safety and Health Fact Sheets, American Welding Society, 550 LeJeune Road, P.O. Box 351040, Miami, FL 33135, www.aws.org/technical/facts/

Section 2

SPECIFICATIONS

In this section

System description.....2-3

- General2-3
- Power supplies.....2-3
- Chiller2-3
- Chiller interface console2-3
- Ignition console.....2-3
- Selection console.....2-3
- Metering console.....2-3
- Torch.....2-3

Specifications2-4

- System gas requirements.....2-4
- Power supplies.....2-5
- Ecodesign requirements for CE models.....2-6
- Critical raw materials2-6
- China Energy Label.....2-7
- Chiller2-8
- Chiller interface console – 0785372-9
- Ignition console – 078536..... 2-10
- Torch lead junction box (Optional) – 078619 2-12
- Selection console – 078533..... 2-13
- Metering console – 078535..... 2-14
- Torch – 228599..... 2-15

IEC symbols..... 2-16

Symbols and Marks..... 2-17

SPECIFICATIONS

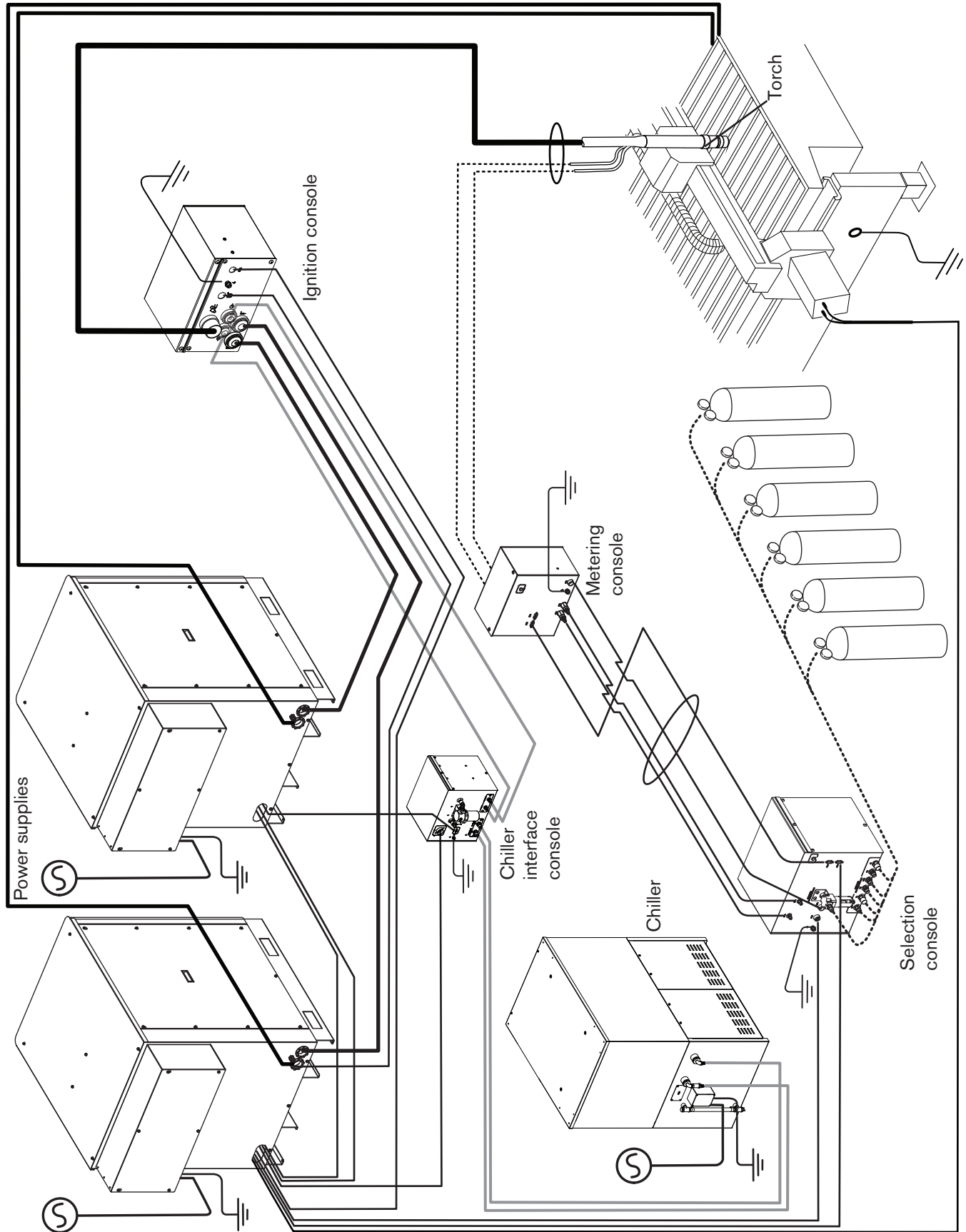

System description

General

HyPerformance plasma systems are designed to cut a wide range of thicknesses of mild steel, stainless steel and aluminum.

Power supplies

Each power supply is a 400-amp, 200-VDC constant-current supply. Each contains the circuitry to ignite a torch. The power supplies have a serial interface to provide communication with a CNC controller.

Chiller

The chiller contains a heat exchanger and pump that reduces the temperature of the coolant that flows to the torch. It also contains flow and temperature sensors that ensure the cooling system is working properly.

Chiller interface console

The chiller interface console controls the coolant flow through the chiller and out to the torch. It monitors the coolant temperature, and flow rate, and filters the coolant returning from the torch.

Ignition console

The ignition console uses a spark-gap assembly. The ignition console converts 120 VAC control voltage from the power supply into high-frequency and high-voltage pulses (9-10 kV) to break over the torch electrode-nozzle gap. The high-voltage, high-frequency signal is coupled to the cathode lead and pilot arc lead.

Selection console

The selection console manages the selection and mixing of the plasma and shield gases. It contains motor valves, solenoid valves and pressure transducers. It also contains a control board, an AC relay board and a power distribution board. The selection console has an LED lamp that illuminates when power is supplied to the system.

Metering console

The metering console controls the pressure (flow rate) of the gases to the torch in real time. It also controls the gas portion of the LongLife[®] process. The metering console contains proportional control valves, a PC control board and a power distribution board. The metering console has an LED that illuminates when power is supplied to the console (remote on).

Torch

The dross-free cutting capacity of the torch is 40 mm (1.5 in) for mild steel HyDefinition cutting. The production pierce capacity is 50 mm (2.0 in) for mild steel and 75 mm (3.0 in) for stainless steel and aluminum. The maximum severance capability (edge start) is 80 mm (3.2 in) for mild steel and 160 mm (6.3 in) for stainless steel and aluminum.

SPECIFICATIONS







Specifications

System gas requirements

Gas quality and pressure requirements			
Gas type	Quality	Pressure +/- 10%	Flow rate
O ₂ oxygen	99.5% pure Clean, dry, oil-free	793 kPa / 8 bar 115 psi	4250 l/h 150 scfh
N ₂ nitrogen	99.99% pure Clean, dry, oil-free	793 kPa / 8 bar 115 psi	11610 l/h 450 scfh
Air	* Clean, dry, oil-free per ISO 8573-1 Class 1.4.2	793 kPa / 8 bar 115 psi	11330 l/h 400 scfh
H35 argon-hydrogen	99.995% pure (H35 = 65% Argon, 35% Hydrogen)	793 kPa / 8 bar 115 psi	5660 l/h 200 scfh
F5 nitrogen-hydrogen	99.98% pure (F5 = 95% Nitrogen, 5% Hydrogen)	793 kPa / 8 bar 115 psi	4250 l/h 150 scfh
Ar argon	99.99% pure Clean, dry, oil-free	793 kPa / 8 bar 115 psi	4250 l/h 150 scfh

* ISO standard 8573-1 Class 1.4.2 requirements are:

- Particulates – no more than 100 particles per cubic meter of air at a size of 0.1 to 0.5 microns in the largest dimension and 1 particle per cubic meter of air at a size of 0.5 to 5.0 microns in the largest dimension.
- Water – the pressure dew point of the humidity must be less than or equal to 3° C (37.4° F).
- Oil – the concentration of oil can be no more than 0.1 mg per cubic meter of air.

	Mild steel		Stainless steel		Aluminum	
						
	Plasma gas	Shield gas	Plasma gas	Shield gas	Plasma gas	Shield gas
Cutting 30 to 50 A	O ₂	O ₂	N ₂ & F5	N ₂	Air	Air
Cutting 80 A	O ₂	Air	F5	N ₂	–	–
Cutting 130 A	O ₂	Air	N ₂ & H35	N ₂	H35 & Air	N ₂ & Air
Cutting 200 A	O ₂	Air	N ₂ & H35	N ₂	N ₂ & H35	N ₂
Cutting 260 A	O ₂	Air	N ₂ & H35	N ₂	N ₂ & H35	N ₂ & Air
Cutting 400 A	O ₂	Air	N ₂ & H35	N ₂ & Air	N ₂ & H35	N ₂ & Air
Cutting 600 A	–	–	N ₂ & H35	N ₂	N ₂ & H35	N ₂
Cutting 800 A	–	–	H35	N ₂	H35	N ₂

Power supplies (each power supply has the following specifications)

General								
Maximum OCV (U_0)			360 VDC					
Maximum output current (I_2)			400 Amps					
Output voltage (U_2)			50 – 200 VDC					
Duty cycle rating (X)			100% @ 80 kw, 40° C (104° F)					
Ambient temperature/Duty cycle			Power supplies will operate between -10° C and +40° C (+14° and 104° F)					
Power factor (cosφ)			0.98 @ 400 ADC output					
Cooling			Forced air (Class F)					
Insulation			Class H					
Power supply			AC Voltage (U_1)	Phase	Frequency (Hz)	Amperage (I_1)	Regulatory approval	Power kVA (+/- 10%) ($U_1 \times I_1 \times 1.73$)
Primary	Primary with Hypernet	Secondary						
078578	078586	078594	200/208	3	50/60	262/252	CSA	90.6
078579	078587	078595	220	3	50/60	238	CSA	90.6
078580	078588	078596	240	3	60	219	CSA	90.6
078581	078589	078597	380*	3	50/60	138	CCC	90.6
078582	078590	078598	400	3	50/60	131	CE/GOST-R	90.6
078583	078591	078599	440	3	50/60	120	CSA	90.6
078584	078592	078600	480	3	60	110	CSA	90.6
078585	078593	078601	600	3	60	88	CSA	90.6

* The 380 volt CCC regulatory approval only applies to 50 Hz operation

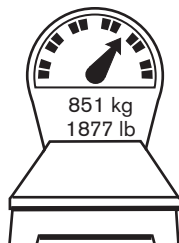

Note: Each power supply has the same dimensions and weight

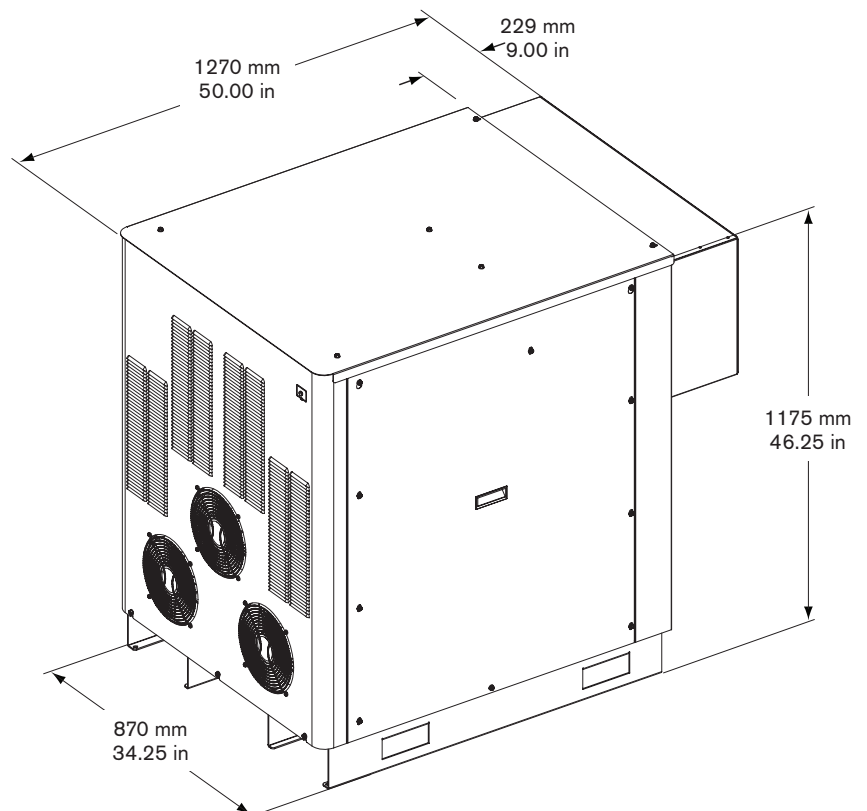

SPECIFICATIONS

Ecodesign requirements for CE models

Ecodesign Requirement	Idle	With load
Output current	–	401.63 A
Output voltage	–	201.68 V
Output active power	–	80.93 kW
The following values were measured at idle state ¹ and at the rated duty cycle for the system at the highest output power:		
Root Mean Square (RMS) of the supply voltage	401.28 V	397.28 V
Supply active power	42.16 W	88.11 kW
Total harmonic distortion of the supply voltage (UTHD)	1.15%	4.37%
The following value was measured at idle state ¹ :		
Idle state power consumption by the power source	42.16 W	–
The following value was calculated at the rated duty cycle for the system at the highest output power:		
Efficiency	–	91.85%

1 External devices were disconnected during idle measurement. A jumper was installed on pins 1 and 3 of TB2 to enable the power supply to remain powered in idle state.

Critical raw materials

Critical raw material	Components that contain more than 1 gram
Borate	All printed circuit boards, torch, torch mounting sleeve
Magnesium	Heatsinks
Natural graphite	Pump motor, resistors
Phosphorus	Sheet metal panels
Rare earth elements (heavy and light)	Torch breakaway, pump motor
Silicon metal	Heatsinks, transformers, inductors, IGBT modules
Tantalum	Capacitors
Tungsten	Power resistors

China Energy Label



1	Energy efficiency rating. Level 1 is most efficient	3	Energy Efficiency (%)
2	<ul style="list-style-type: none"> Manufacturer Plasma power supply model 	4	<ul style="list-style-type: none"> Rated output Current Power factor under load No-load current

Input voltage (V)	Power Level	Efficiency (%)	Rated Current(A)	Power Factor under load	No-Load current
220	2	90	400	0.90	/

SPECIFICATIONS

Chiller

- See the chiller manufacturer manual for specifications on dimensions, weight and coolant capacity.
- Maximum hose length from the chiller to the chiller interface console is 15 meters (50 ft).
- Allow 1 m (3 ft) of space on all sides of the cooler for ventilation and service, and 1.4 m (4 ft) for clearance from the top of the chiller.

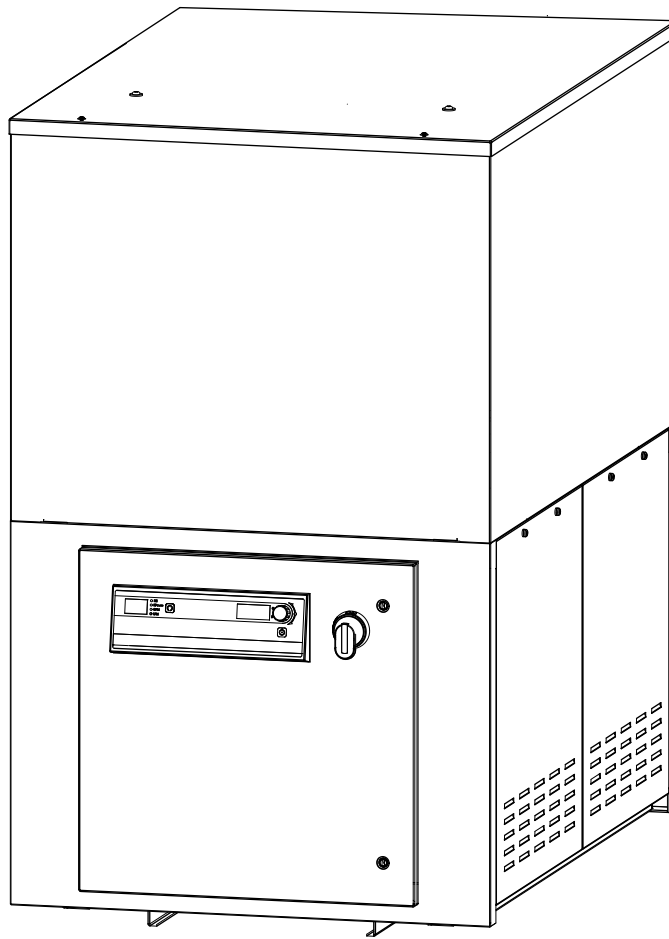

Chiller interface console – 078537

- Mount the chiller interface console in a horizontal position.
- Allow room to remove the top for servicing.
- Do not mount the chiller interface console on top of the power supply.

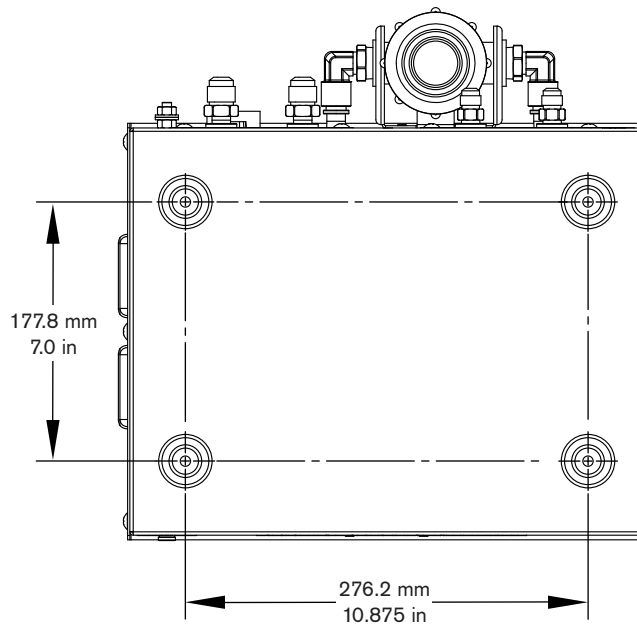
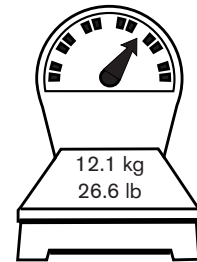
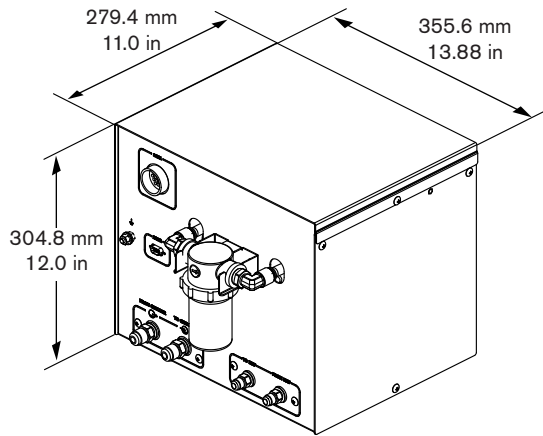

SPECIFICATIONS

Ignition console – 078536

- The ignition console can be mounted remotely on the cutting table's bridge. See *Installation* section for details.
- Maximum cable length from the ignition console to the torch lifter station is 15 m (50 ft). Allow room to remove the top for servicing.
- The ignition console may be mounted horizontally or vertically.

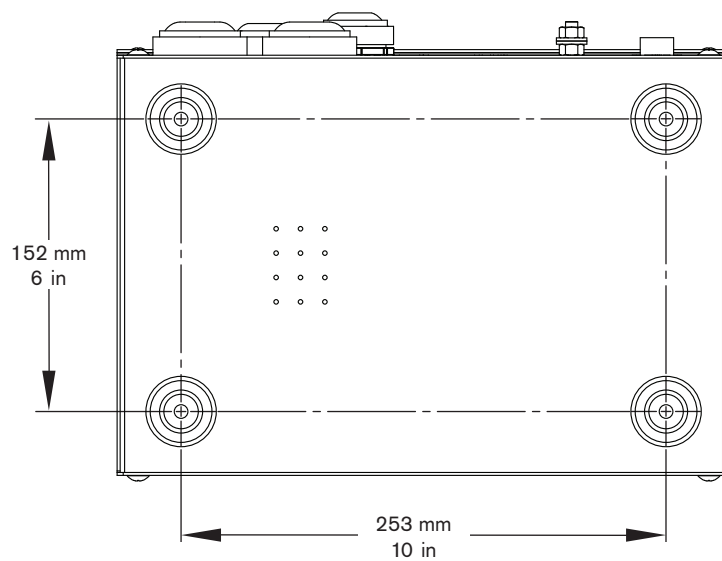
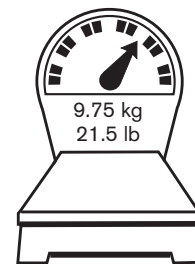
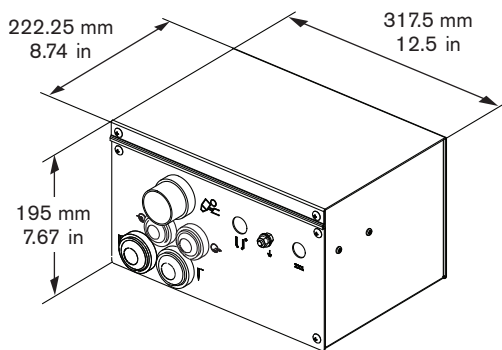

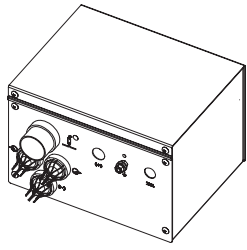

Horizontal mounting

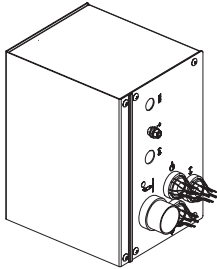

Vertical mounting

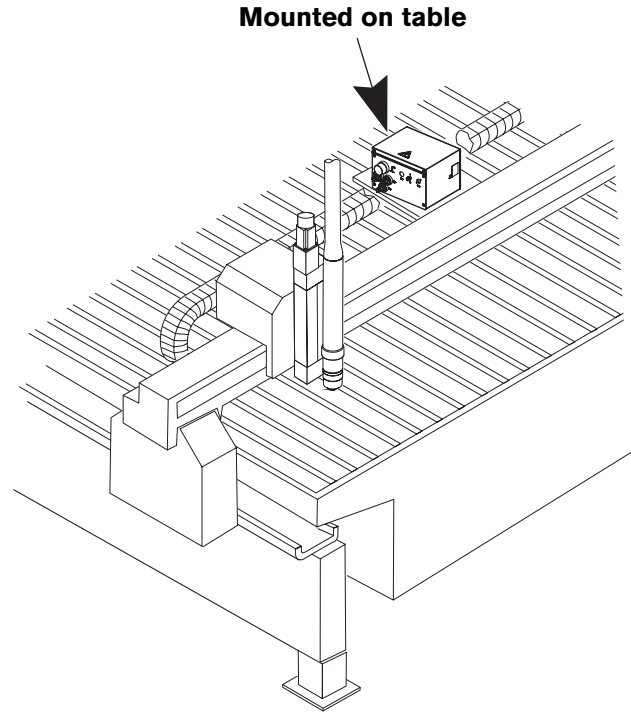

SPECIFICATIONS

Torch lead junction box (Optional) – 078619

- The junction box provides increased installation flexibility by creating a break point in the leads between the ignition console and torch to facilitate easier replacement of torch leads in certain applications.
- Maximum combined lead length from the ignition console to the torch must be less than or equal to:
 - 20 m (65 feet) for HPR130XD / HPR260XD
 - 15 m (50 feet) for HPR400XD / HPR800XD

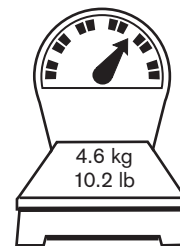
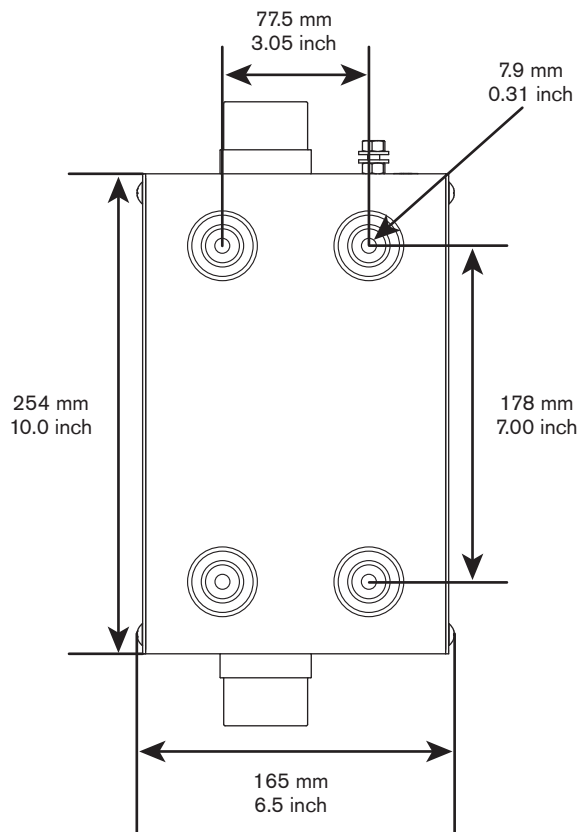
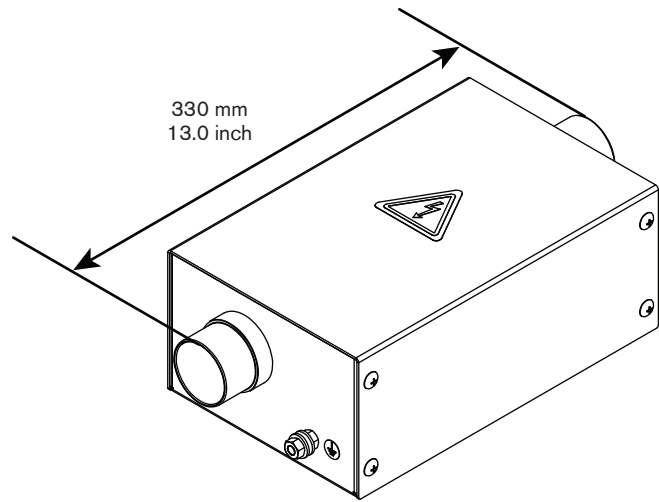
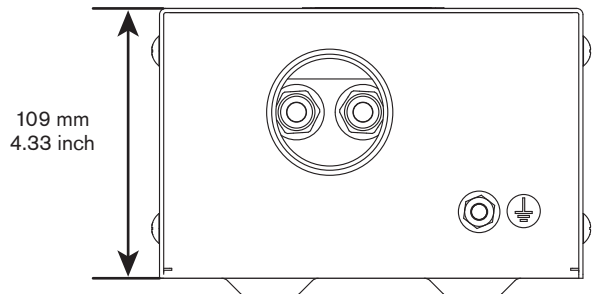

Selection console – 078533

- Maximum cable length from the power supply to the selection console is 75 m (250 ft).
- Maximum cable length from the selection console to the metering console is 20 m (65 ft).
- Mount the selection console on top of the power supply or near the CNC on the cutting table. Allow room to open the top for servicing.

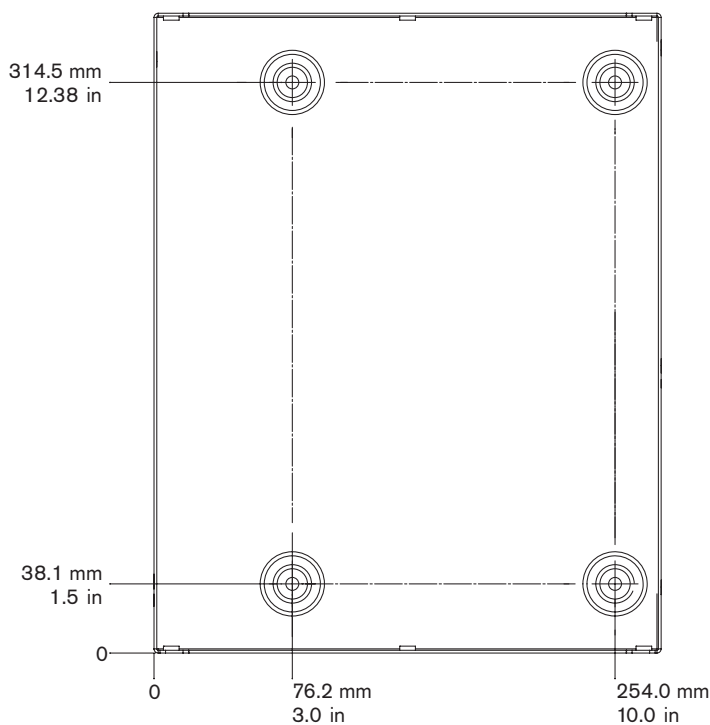
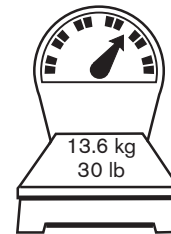
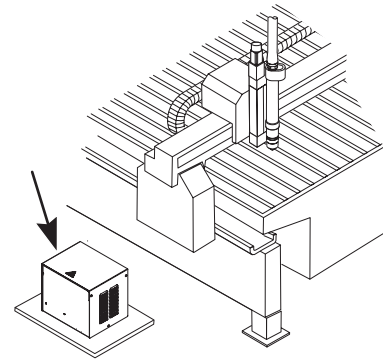
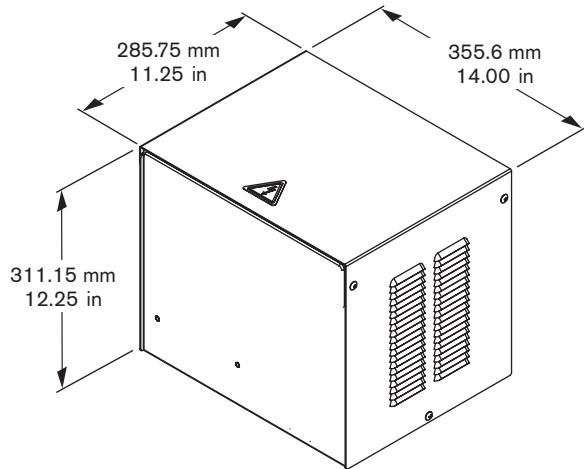

SPECIFICATIONS

Metering console – 078535

- Maximum cable length from the metering console to the torch lifter station is 1.8 m (6 ft).
- Mount the metering console to the torch carriage on larger tables. On smaller tables it can be mounted to a bracket just above the bridge.
- The vent hole on the console must be kept clear at all times.

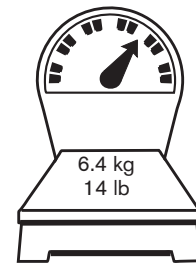
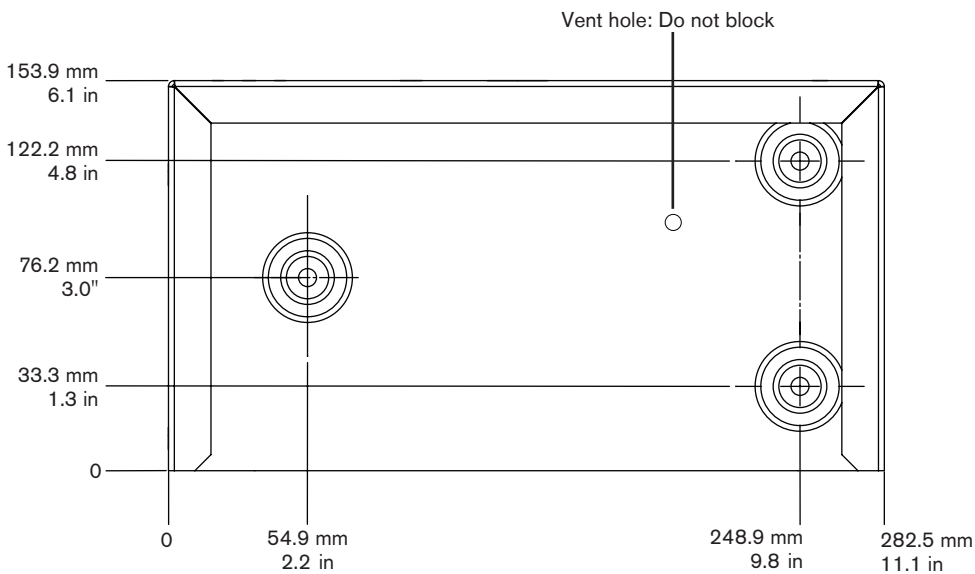
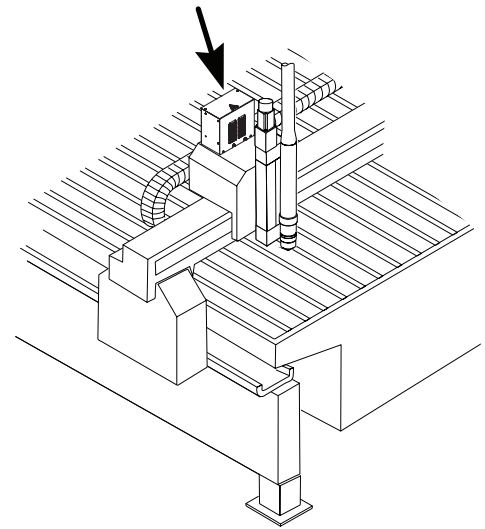
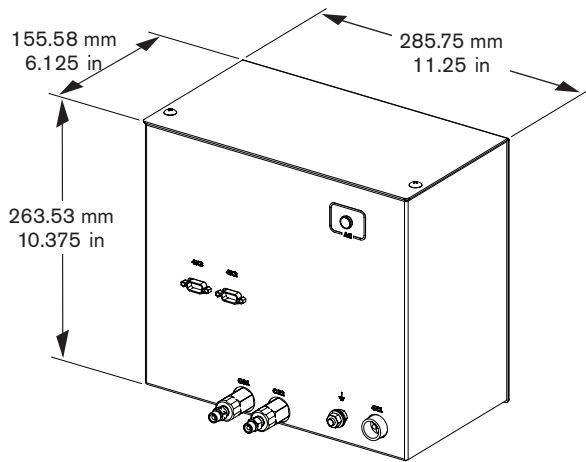

Torch – 228599



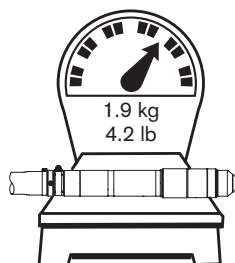
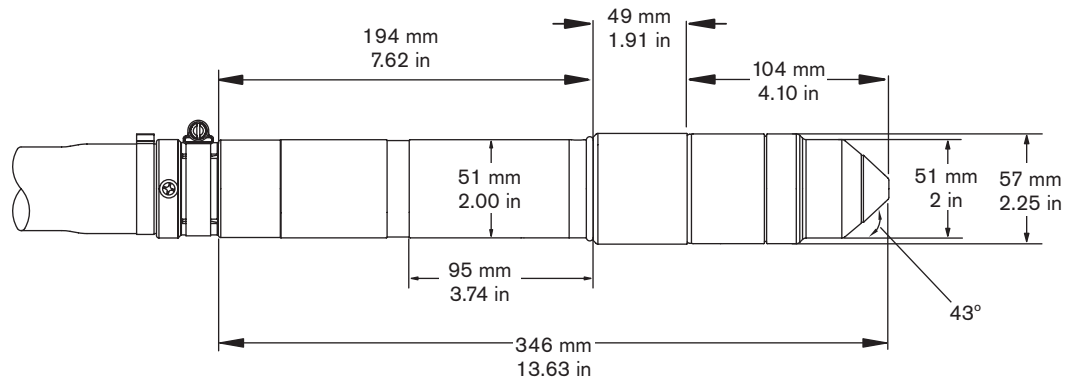
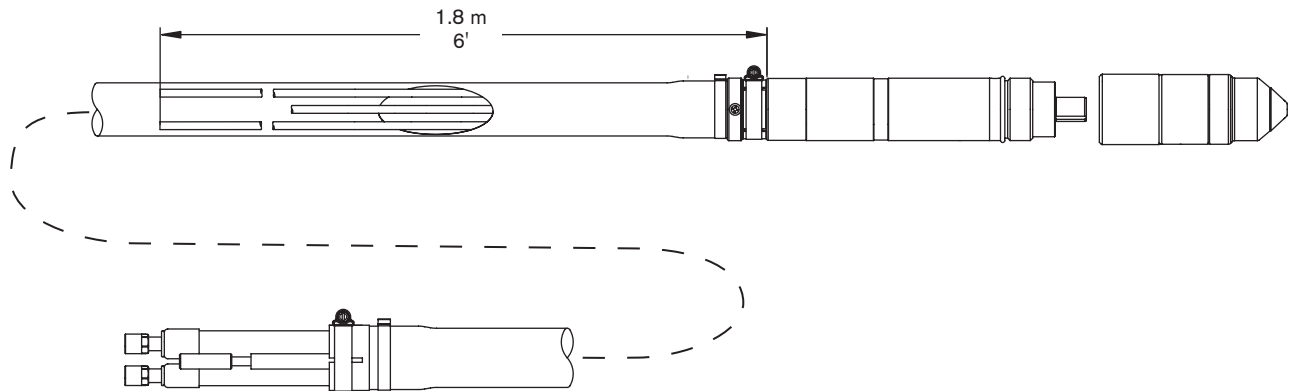











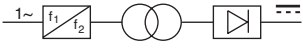

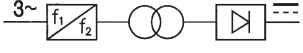
- The outside diameter of the torch mounting sleeve is 50.8 mm (2.0 in).
- The minimum bend radius for the torch leads is 152.4 mm (6.0 in).



SPECIFICATIONS

IEC symbols

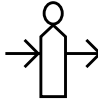
The following symbols may appear on the power supply data plate, control labels, switches, LEDs, and LCD screen.

	Direct current (DC)		Power is ON
	Alternating current (AC)		Power is OFF
	Plasma torch cutting		An inverter-based power source, either 1-phase or 3-phase
	Plate metal cutting		
	Expanded metal cutting		Volt/amp curve, "drooping" characteristic
	Gouging		Power is ON (LED)
	AC input power connection		System fault (LED)
	The terminal for the external protective (earth) conductor		Inlet gas pressure fault (LCD)
			Missing or loose consumables (LCD)
			Power supply is out of temperature range (LCD)

Symbols and Marks

Your product may have one or more of the following marks on or near the data plate. Because of differences and conflicts in national regulations, not all marks are applied to every version of a product.



S mark

The S mark indicates that the power supply and torch are suitable for operations carried out in environments with increased hazard of electrical shock according to IEC 60974-1.



CSA mark

Products with a CSA mark meet the United States and Canadian regulations for product safety. The products were evaluated, tested, and certified by CSA-International. Alternatively, the product may have a mark by one of the other Nationally Recognized Testing Laboratories (NRTL) accredited in both the United States and Canada, such as UL or TÜV.



CE mark

The CE marking signifies the manufacturer's declaration of conformity to applicable European directives and standards. Only those versions of products with a CE marking located on or near the data plate comply with European Directives. Applicable directives may include the European Low Voltage Directive, the European Electromagnetic Compatibility (EMC) Directive, the Radio Equipment Directive (RED), and the Restriction of Hazardous Substances (RoHS) Directive. See the European CE Declaration of Conformity for details.



Eurasian Customs Union (CU) mark

CE versions of products that include an EAC mark of conformity meet the product safety and EMC requirements for export to Russia, Belarus, and Kazakhstan.



GOST-TR mark

CE versions of products that include a GOST-TR mark of conformity meet the product safety and EMC requirements for export to the Russian Federation.



RCM mark

CE versions of products with a RCM mark comply with the EMC and safety regulations required for sale in Australia and New Zealand.



CCC mark

The China Compulsory Certification (CCC) mark indicates that the product has been tested and found compliant with product safety regulations required for sale in China.



UkrSEPRO mark

The CE versions of products that include a UkrSEPRO mark of conformity meet the product safety and EMC requirements for export to the Ukraine.



Serbian AAA mark

CE versions of products that include a AAA Serbian mark meet the product safety and EMC requirements for



RoHS mark

The RoHS mark indicates that the product meets the requirements of the European Restriction of Hazardous Substances (RoHS) Directive.



United Kingdom Conformity Assessed mark

CE versions of products that include a UKCA mark of conformity meet the product safety, EMC, RF, and RoHS requirements for export to the UK.

This page is blank intentionally

Section 3

INSTALLATION

In this section:

Upon receipt	3-3
Claims.....	3-3
Installation requirements	3-3
Noise levels	3-3
Placement of system components.....	3-3
Installation requirements	3-4
System components.....	3-5
Cables and hoses	3-5
Customer-supplied power cables	3-5
Supply gas hoses.....	3-5
Recommended grounding and shielding practices	3-6
Introduction	3-6
Types of grounding.....	3-6
Grounding practices.....	3-6
Grounding diagram	3-9
Placement of the primary power supply	3-11
Placement of the secondary power supply.....	3-12
Lifting the power supply.....	3-13
Install the ignition console.....	3-15
Placement of the chiller	3-17
Install the chiller interface console.....	3-18
Install the metering console.....	3-19
Placement of the selection console.....	3-20
Primary power supply to secondary power supply cables.....	3-21
Interface (on/off) cable.....	3-21
Communication cable.....	3-22
Power supply to ignition console leads	3-23
Pilot arc lead.....	3-23
Negative leads.....	3-23
Ignition console power cable (from primary power supply).....	3-25
Coolant hose set (chiller to chiller-interface console)	3-26
Coolant hose set (chiller-interface console to ignition console).....	3-27

INSTALLATION

Primary power supply to chiller interface console.....	3-28
Chiller interface power cable.....	3-28
Secondary power supply to chiller interface console.....	3-29
Chiller interface communication cable	3-29
Primary Power supply to selection console cables.....	3-30
Selection console communication cable	3-30
Selection console power cable.....	3-30
Selection console to metering console hose and lead assembly.....	3-32
Cable and gas hose assembly	3-32
Power supply to CNC interface cable.....	3-34
Optional multi-system CNC interface cable.....	3-34
Examples of output circuits.....	3-36
Examples of input circuits.....	3-37
Remote ON/OFF switch (provided by customer).....	3-38
Torch lead assembly.....	3-39
Torch lead junction box (Optional).....	3-40
Install the junction box.....	3-41
Connect the leads.....	3-42
Work lead.....	3-46
Torch connections.....	3-47
Connect the torch to the torch lead assembly	3-47
Connect the torch to the quick-disconnect	3-51
Torch mounting and alignment.....	3-52
Mounting the torch.....	3-52
Torch alignment.....	3-52
Torch lifter requirement	3-53
HyperNet.....	3-53
Power requirements (for each power supply)	3-54
General	3-54
Line disconnect switch.....	3-55
Main power cable (power supplies)	3-55
Main power cable (chiller).....	3-55
Connect the power.....	3-56
Torch coolant requirements	3-57
Premixed coolant for standard operating temperatures	3-57
Custom Coolant mix for cold operating temperatures.....	3-58
Custom Coolant mix for hot operating temperatures.....	3-59
Water purity requirements	3-59
Fill the chiller with coolant.....	3-60
Gas requirements	3-61
Setting the supply regulators.....	3-61
Gas regulators.....	3-62
Supply gas plumbing	3-63
Connect the supply gases	3-64
Supply gas hoses	3-65

Upon receipt

- Verify that all system components on your order have been received. Contact your supplier if any items are missing.
- Inspect the system components for any physical damage that may have occurred during shipping. If there is evidence of damage, refer to *Claims*. All communications regarding claims must include the model number and serial number located on the rear of the power supply.

Claims

Claims for damage during shipment – If your unit was damaged during shipment, you must file a claim with the carrier. Hypertherm will furnish you with a copy of the bill of lading upon request. If you need additional assistance, call Customer Service listed in the front of this manual, or your authorized Hypertherm distributor.

Claims for defective or missing merchandise – If any of the merchandise is defective or missing, contact your supplier. If you need additional assistance, call Customer Service listed in the front of this manual, or your authorized Hypertherm distributor.

Installation requirements

All installation and service of the electrical and plumbing systems must conform to national and local electrical and plumbing codes. This work should be performed only by qualified, licensed personnel.

Direct any technical questions to the nearest Hypertherm Technical Service Department listed in the front of this manual, or your authorized Hypertherm distributor.

Noise levels

Acceptable noise levels as defined by national and local codes may be exceeded by this plasma system. Always wear proper ear protection when cutting or gouging. Any noise measurements taken are dependant on the specific environment in which the system is used. See also *Noise can damage hearing* in the *Safety* section of this manual. Specific information by product can be found in the Hypertherm downloads library at:

<https://www.hypertherm.com/Xnet/library/DocumentLibrary.jsp>

Select the product you are looking for from the Product Type drop down menu, choose “Regulatory” from the Category drop down menu, and choose “Acoustical Noise Data Sheets” from the Sub Category drop down menu. Hit Submit.

Placement of system components

- Place all system components in position prior to making electrical, gas, and interface connections. Use the diagram in this section for component-placement guidelines.
- Ground all system components to earth. See *Recommended grounding and shielding practices* in this section for details.
- To prevent leaks in the system, tighten all gas and water connections as shown below:

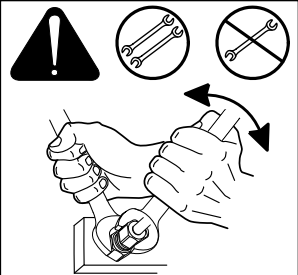
	Torque specifications		
	Gas or water hose size	kgf-cm	lbf-in
Up to 10 mm (3/8 in)	8.6-9.8	75-85	6.25-7
12 mm (1/2 in)	41.5-55	360-480	30-40

INSTALLATION

Installation requirements

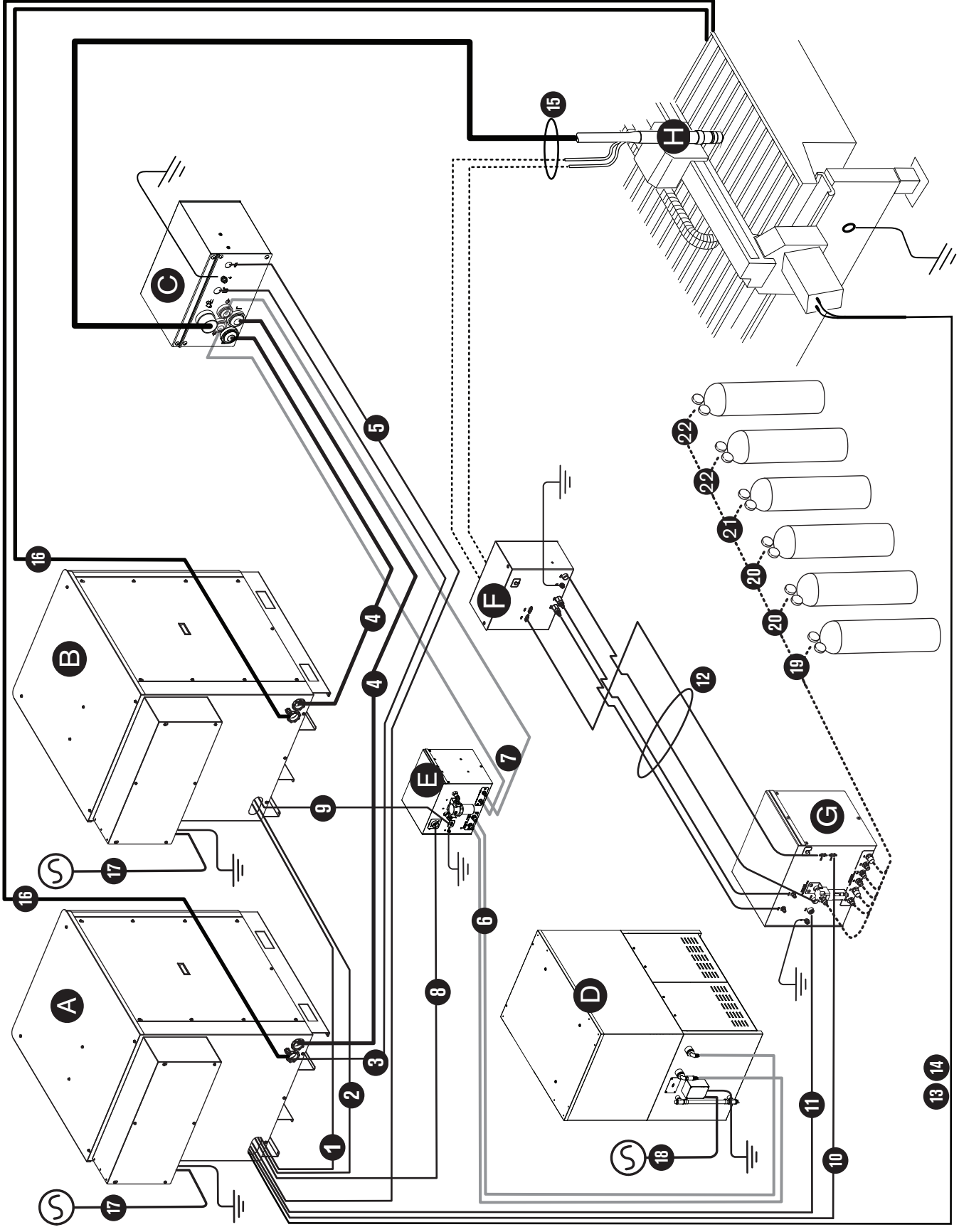

System components

- A** Primary power supply
- B** Secondary power supply
- C** Ignition console
- D** Chiller
- E** Chiller interface console
- F** Metering console
- G** Selection console
- H** Torch

Cables and hoses

- 1** Primary power supply to secondary power supply interface cable
- 2** Primary power supply to secondary power supply communication cable
- 3** Pilot arc lead
- 4** Negative leads
- 5** Ignition console power cable
- 6** Coolant hoses (chiller to chiller-interface console)
- 7** Coolant hoses (chiller interface console to ignition console)
- 8** Chiller interface power cable
- 9** Chiller interface communication cable
- 10** Selection console communication cable
- 11** Selection console power cable
- 12** Selection console to metering console hose and lead assembly
- 13** CNC interface cable
- 14** Optional CNC interface cable for systems with multiple power supplies
- 15** Torch lead assembly
- 16** Work leads



Customer-supplied power cables

- 17** Main power cables (power supplies)
- 18** Main power cable (chiller)

Supply gas hoses

- 19** Oxygen
- 20** Nitrogen or argon
- 21** Air
- 22** Argon-hydrogen (H35) or nitrogen-hydrogen (F5)

Recommended grounding and shielding practices

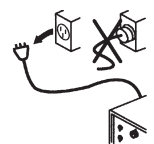
		WARNING! ELECTRIC SHOCK CAN KILL
	Disconnect electrical power before performing any maintenance. All work requiring the removal of the plasma system cover must be performed by a qualified technician. See the <i>Safety</i> section of your manual for more safety precautions.	

Introduction

This section describes practices for grounding and shielding to protect a plasma cutting system against radio frequency interference (RFI) and electromagnetic interference (EMI) (also called *noise*). It also describes the DC power ground and the service ground. The diagram at the end of this section shows these types of grounds in a plasma cutting system.

Note: The grounding practices in this section have been used on many installations with excellent results, and Hypertherm recommends that these practices be a routine part of the installation process. The actual methods used to implement these practices may vary from system to system, but should remain as consistent as possible. However, due to the variation in equipment and installations, these grounding practices may not succeed in every case to eliminate RFI/EMI noise issues.

Types of grounding

Service ground (also called safety ground or potential earth (PE) ground) is the grounding system that applies to the incoming line voltage. It prevents a shock hazard to any personnel from any of the equipment or the cutting table. It includes the service ground coming into the plasma system and other systems such as the CNC and the motor drives, as well as the supplemental ground rod connected to the cutting table. In the plasma circuits, the ground is carried from the plasma system chassis to the chassis of each separate console through the interconnecting cables.

DC power ground (also called cutting current ground) is the grounding system that completes the path of the cutting current from the torch back to the plasma system. It requires that the positive lead from the plasma system be firmly connected to the cutting table ground bus with a properly sized cable. It also requires that the slats, on which the workpiece rests, make firm contact with the table and the workpiece.

RFI and EMI grounding and shielding is the grounding system that limits the amount of electrical noise emitted by the plasma and motor drive systems. It also limits the amount of noise that is received by the CNC and other control and measurement circuits. The grounding practices described in this section mainly target RFI and EMI grounding and shielding.

Grounding Practices

1. Unless noted, use only 13.3 mm² (6 AWG) welding cables (047040) for the EMI ground cables shown on the diagram at the end of this section.
2. The cutting table is used for the common, or star, EMI ground point and should have threaded studs welded to the table with a copper bus bar mounted on them. A separate bus bar should be mounted on the gantry as close to each motor as possible. If there are motors at each end of the gantry, run a separate EMI ground

cable from the far motor to the gantry bus bar. The gantry bus bar should have a separate, heavy EMI ground cable 21.2 mm² (4 AWG; 047031) to the table bus bar. The EMI ground cables for the torch lifter and the RHF console must each run separately to the table ground bus.

3. Inadequate grounding not only exposes operators to dangerous voltages, but inadequate grounding also increases the risk of equipment failure and unnecessary downtime. Ideally a ground should be zero ohms resistance, but field experience indicates under 1 ohm resistance is satisfactory for most applications. Hypertherm recommends that you consult your national and local electrical codes to make sure that the grounding and shielding practices that you use comply with the requirements for your location.
4. A ground rod that meets all applicable local and national electrical codes must be installed within 6 m (20 ft) of the cutting table. This is a PE ground and should be connected to the cutting table ground bus bar using 13.3 mm² (6 AWG) green and yellow grounding cable (047121) or equivalent.
5. For the most effective shielding, use the Hypertherm CNC interface cables for I/O signals, serial communication signals, between plasma systems in multi-drop connections, and for interconnections between all parts of the Hypertherm system.
6. All hardware used in the ground system must be brass or copper. While you can use steel studs welded to the cutting table for mounting the ground bus, no other aluminum or steel hardware can be used in the ground system.
7. AC power, PE, and service grounds must be connected to all equipment according to local and national codes.
8. For a system with a remote high frequency console (RHF), the positive, negative, and pilot arc leads should be bundled together for as long a distance as possible. The torch lead, work lead, and the pilot arc (nozzle) leads may be run parallel to other wires or cables only if they are separated by at least 150 mm (6 inches). If possible, run power and signal cables in separate cable tracks.
9. For a system with an RHF console, the ignition console should be mounted as closely as possible to the torch, and must have a separate ground cable that connects directly to the cutting table ground bus bar.
10. Each Hypertherm component, as well as any other CNC or motor drive cabinet or enclosure, must have a separate ground cable to the common (star) ground on the table. This includes the ignition console, whether it is bolted to the plasma system or to the cutting table.
11. The metal braided shield on the torch lead must be connected firmly to the ignition console and to the torch. It must be electrically insulated from any metal and from any contact with the floor or building. The torch lead can be run in a plastic cable tray or track, or covered with a plastic or leather sheath.
12. The torch holder and the torch breakaway mechanism – the part mounted to the lifter, not the part mounted to the torch – must be connected to the stationary part of the lifter with copper braid at least 12.7 mm (0.5 inches) wide. A separate cable must run from the lifter to the gantry ground bus bar. The valve assembly should also have a separate ground connection to the gantry ground bus bar.
13. If the gantry runs on rails that are not welded to the table, then each rail must be connected with a ground cable from the end of the rail to the table. The rail ground cables connect directly to the table and do not need to connect to the table ground bus bar.
14. If you are installing a voltage divider board, mount it as closely as possible to where the arc voltage is sampled. One recommended location is inside the plasma system enclosure. If a Hypertherm voltage divider board is used, the output signal is isolated from all other circuits. The processed signal should be run in twisted shielded cable (Belden 1800F or equivalent). Use a cable with a braided shield, not a foil shield. Connect the shield to the chassis of the plasma system and leave it unconnected at the other end.
15. All other signals (analog, digital, serial, and encoder) should run in twisted pairs inside a shielded cable. Connectors on these cables should have a metal housing. The shield, not the drain, should be connected to the metal housing of the connector at each end of the cable. Never run the shield or the drain through the connector on any of the pins.

INSTALLATION

The following picture shows an example of a cutting table ground bus. The components shown here may differ from your system.

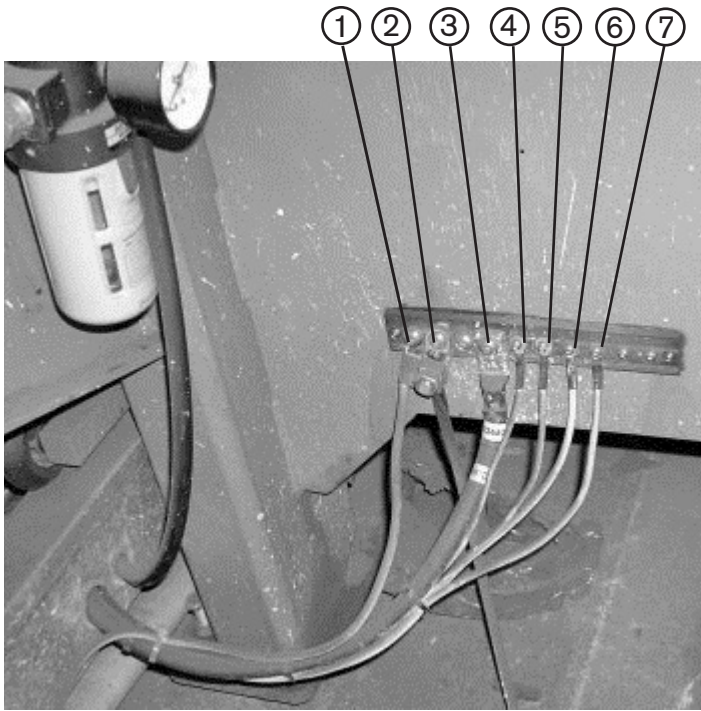

- 1 Gantry ground bus
- 2 Ground rod
- 3 Plasma system work lead (+)
- 4 Remote high frequency (RHF) console
- 5 CNC enclosure
- 6 Torch holder
- 7 Plasma system chassis

The following picture shows an example of a gantry ground bus. It is bolted to the gantry, close to the motor. All of the individual ground cables from the components mounted on the gantry connect to the bus. A single heavy cable then connects the gantry ground bus to the table ground bus.

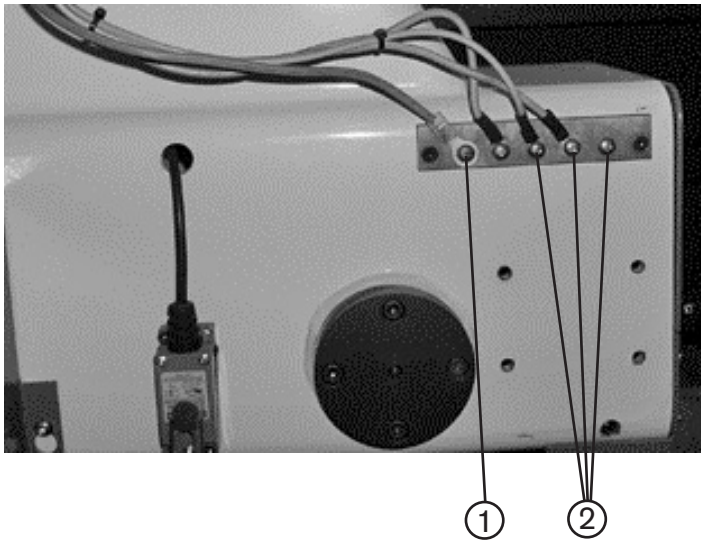

- 1 Cable to the cutting table ground bus
- 2 Ground cables from components on the gantry

Grounding diagram

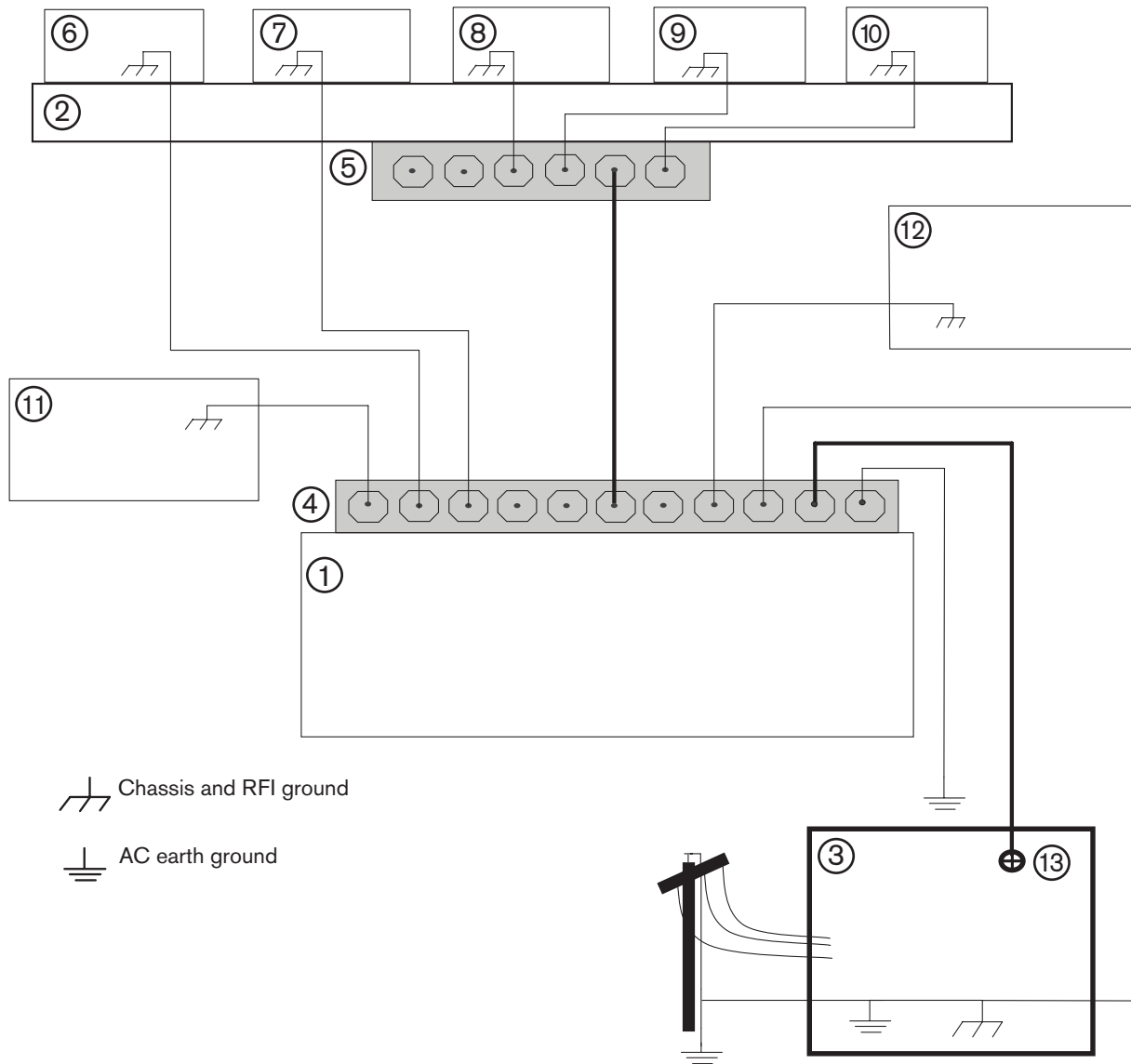

The following diagram shows an example of grounding the components in a plasma cutting system.



- | | |
|--|---|
| <ul style="list-style-type: none"> 1 Cutting table 2 Gantry 3 Plasma system 4 Table ground bus bar 5 Gantry ground bus bar 6 Torch height control lifter (ArcGlide®, Sensor™ THC, Sensor PHC, or other) 7 RHF console (not on all systems). Connect to table ground bus bar. | <ul style="list-style-type: none"> 8, 9 System-specific component such as metering console, gas console, or selection console 10 CNC chassis 11 Torch height control module (ArcGlide®, Command® THC) 12 System-specific component such as a cooler or chiller 13 DC power ground |
|--|---|

This page is blank intentionally

A Placement of the primary power supply

		<p>DANGER ELECTRIC SHOCK CAN KILL</p>
<p>Remove all electrical connections to the power supply before moving or positioning. Transporting the unit can cause personal injury and equipment damage.</p>		

The power supply can be moved by forklift but the forks must be long enough to extend the entire length of the base. Take care when lifting so that the underside of the power supply is not damaged. The forks must also be centered front to back and side to side to prevent tipping while moving. Fork lift speeds should be kept to a minimum, especially when making a turn or going around a corner.

- Place the power supply in an area that is free of excessive moisture, has proper ventilation and is relatively clean. Allow 1 m (3 ft) of space on all sides of the power supply for ventilation and service.
- Cooling air is drawn in through the front panel and is exhausted through the rear of the unit by a cooling fan. Do not place any filter device over the air intake locations, which reduces cooling efficiency and **VOIDS THE WARRANTY.**
- Do not place the power supply on an incline greater than 10° to prevent it from toppling.

HPR400XD power supplies with serial number HPR400-000560 or later can be upgraded to a HPR800XD primary or secondary power supply.

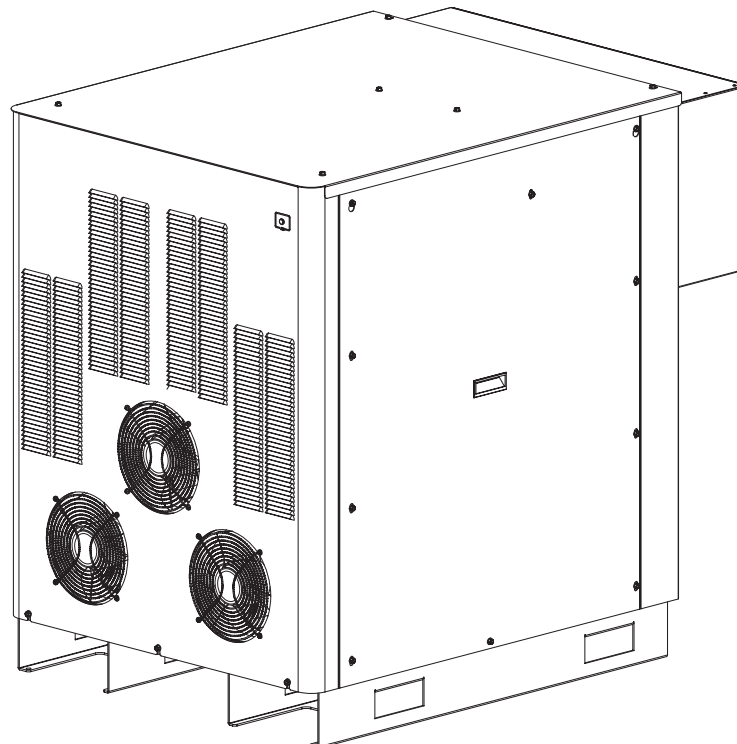

B Placement of the secondary power supply

	<p style="text-align: center;">DANGER ELECTRIC SHOCK CAN KILL</p>
<p>Remove all electrical connections to the power supply before moving or positioning. Transporting the unit can cause personal injury and equipment damage.</p>	

- Place the power supply in an area that is free of excessive moisture, has proper ventilation, and is relatively clean. The components of the plasma system are not intended to be exposed to rain or snow. Allow 1 m (3 ft) of space on all sides of the power supply for ventilation and service.
- Cooling air is drawn in through the front panel and is exhausted through the rear of the unit by a cooling fan. Do not place any filter device over the air intake locations, which reduces cooling efficiency and **VOIDS THE WARRANTY**.
- Do not place the power supply on an incline greater than 10°, to prevent it from toppling.

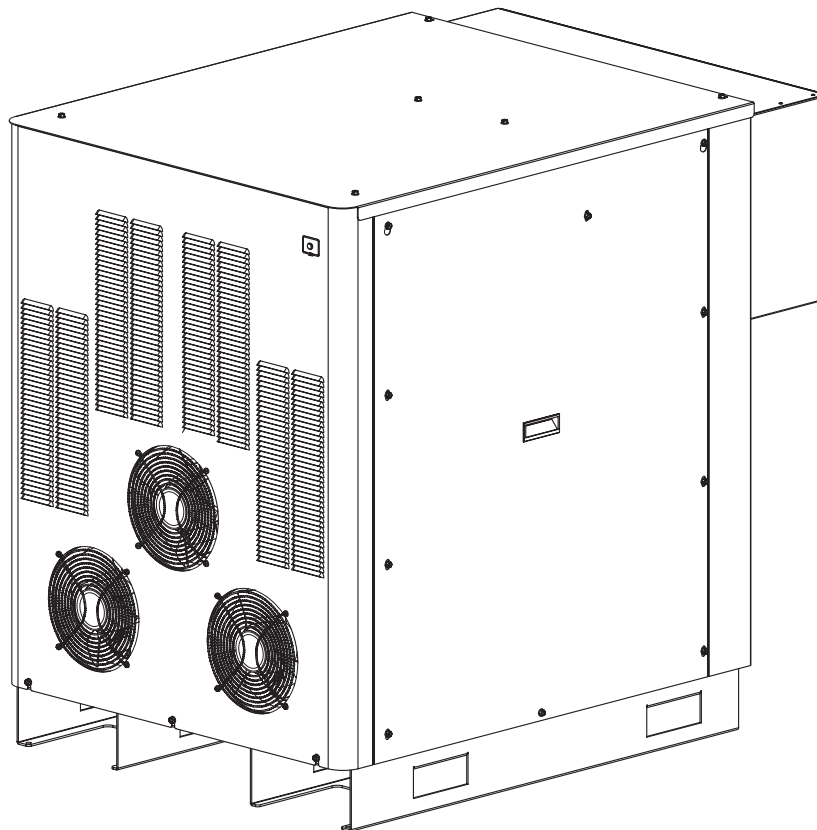

Lifting the power supply

		DANGER
<p>The HPR800XD power supplies weigh approximately 746 kg (1645 lbs) each. 1 or 2 person manual pushing or lifting could cause injury. Use appropriate lifting aids and techniques when moving a power supply</p>		

A strap kit (228336) for lifting the power supplies is available from Hypertherm. The strap kit should only be used to lift the power supplies as outlined herein. Before using the strap kit, the customer understands and assumes exclusive responsibility for supplying personnel trained and qualified to operate forklifts, cranes, hoists and other lifting devices to lift or move the power supplies. All movement of the power supplies must be done in compliance with applicable local laws and regulations. All handling equipment must be evaluated for each application and inspected and tested before each use. The power supplies can be moved by forklift, but the forks must be long enough to extend the entire length of the base. Take care when lifting so that the underside of the power supplies is not damaged. The customer agrees to observe and ensure compliance with the following:

- The straps and other handling equipment must comply with applicable local standards, laws and regulations.
- The rated capacity, design factor, and efficiency rating of the lifting system, including the straps sold by Hypertherm, may be affected by wear, misuse, overloading, corrosion, deformation, intentional alteration, age, and other use conditions. An inspection of the straps by qualified personnel should be conducted before each use. Worn or damaged straps may not be used, nor may they be altered or modified in any way.
- All 4 loops at the ends of the straps must be securely and properly attached to the lifting mechanism.
- The power supply is a nonsymmetrical load; ensure that an analysis by a qualified person is performed properly to balance the load to prevent tipping and overloading of any one strap.
- All enclosure panels must be securely fastened before lifting the power supply.
- The lifting mechanism must be rated for the appropriate weight and be suitable for the strap size.
- Each strap should pass through all 4 holes in the base of the power supply and should not be twisted, constricted, bunched or pinched.

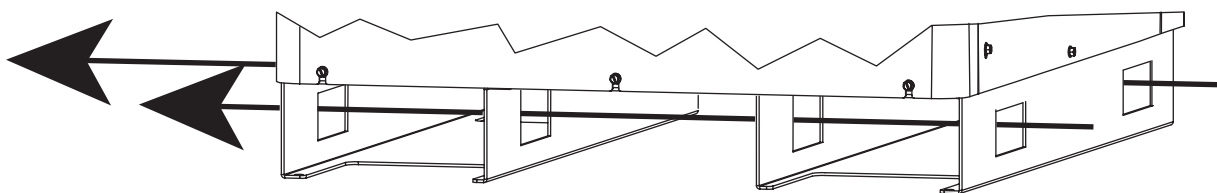

Correct path for lifting straps

- Straps shall not be shortened or lengthened by knotting, twisting, choker hitching, or other means.
- Each power supply should be lifted slowly, not more than 203 mm (8 in.) above the floor, to insure that the weight is evenly distributed.
- Each power supply should be moved slowly to prevent sudden acceleration and deceleration when moving.
- Access to the area should be restricted when moving or lifting to prevent injury of personnel if the power supply shifts or tips.

INSTALLATION

- Personnel should never be allowed to place themselves or any part of the body under the equipment, or between the equipment and walls or other solid objects.
- Store straps in a proper manner such that they are not subjected to mechanical, chemical, or ultraviolet damage, or to extreme temperatures.

In the United States, OSHA regulates slings in 29 CFR 1910.184. This regulation covers general requirements, basic definitions, safe operating practices, and inspections of the various types of slings. Read the OSHA regulations and OSHA sling guidelines carefully before moving the power supply, and observe all requirements and recommendations for safe handling in 29 CFR 1910.184 and other applicable sections. If there is any question respecting the interpretation or application of these or other OSHA regulations, you should consult appropriate legal counsel.

Hypertherm slings are not for sale in Europe, where locally purchased slings are required to have "CE Marking." In the UK the interpretation of the European Directives translated into the following UK Statutory Instruments (SI): SI 2306 PUWER, The Provision and Use of Work Equipment Regulations and SI 2307 LOLER, Lifting Operations Lifting Equipment Regulations. Reference to the European Directives may not be construed to mean that the strap kit may be used in other countries or jurisdictions.

The body responsible for the workplace where the equipment is to be installed needs to ensure all applicable local regulations are followed, and Hypertherm assumes no responsibility or liability therefore. The customer assumes exclusive responsibility for ensuring that all local laws and regulations are followed, including those applicable to the use of equipment and work place conditions.

© Install the ignition console

- Mount the ignition console in a vertical or horizontal position.
- Allow room to remove the top for servicing.

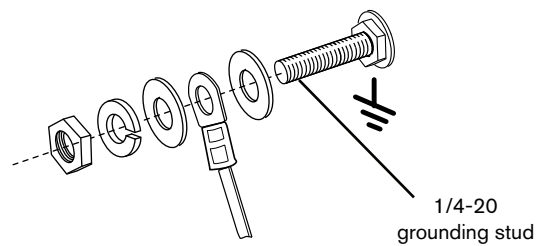
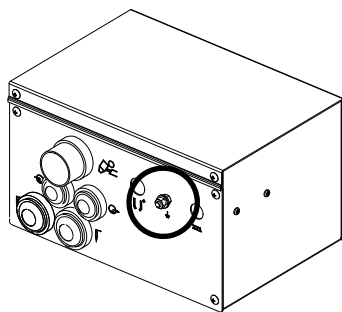
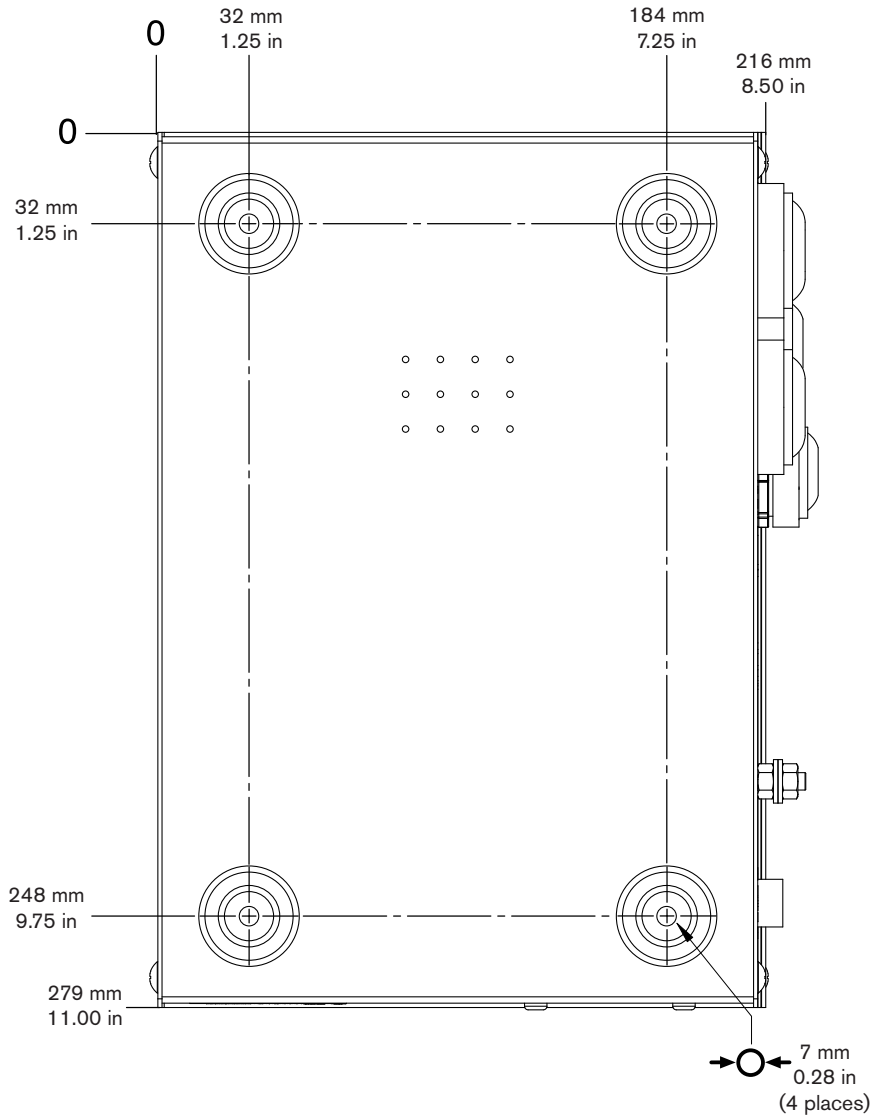

Ignition console grounding

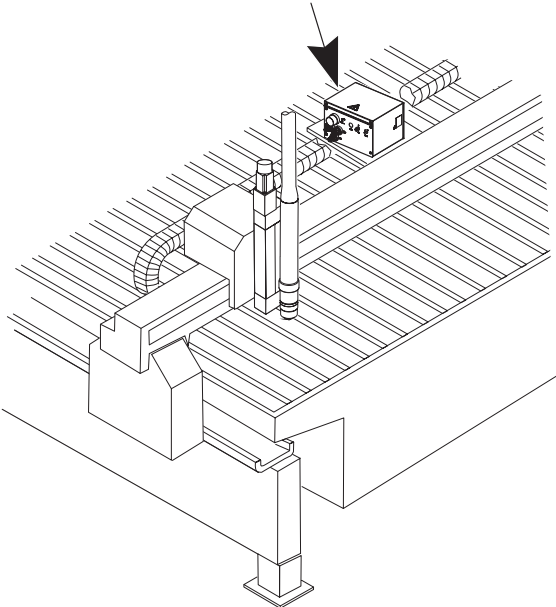

Horizontal RHF mounting

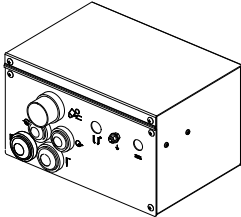

Vertical RHF mounting

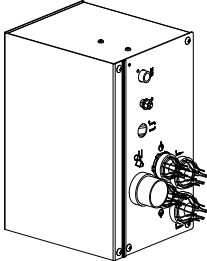

D Placement of the chiller

- Place the chiller in an area that is free of excessive moisture, has proper ventilation, and is relatively clean. The components of the plasma system are not intended to be exposed to rain or snow. Allow 1 m (3 ft) of space on all sides of the chiller for ventilation and service.
- See the chiller manufacturer manual for intake and exhaust information as well as operation and maintenance information.
- Do not place the cooler on an incline greater than 10° (with the wheels locked, if applicable) to prevent it from toppling.

Note: The chiller shown below is generic.

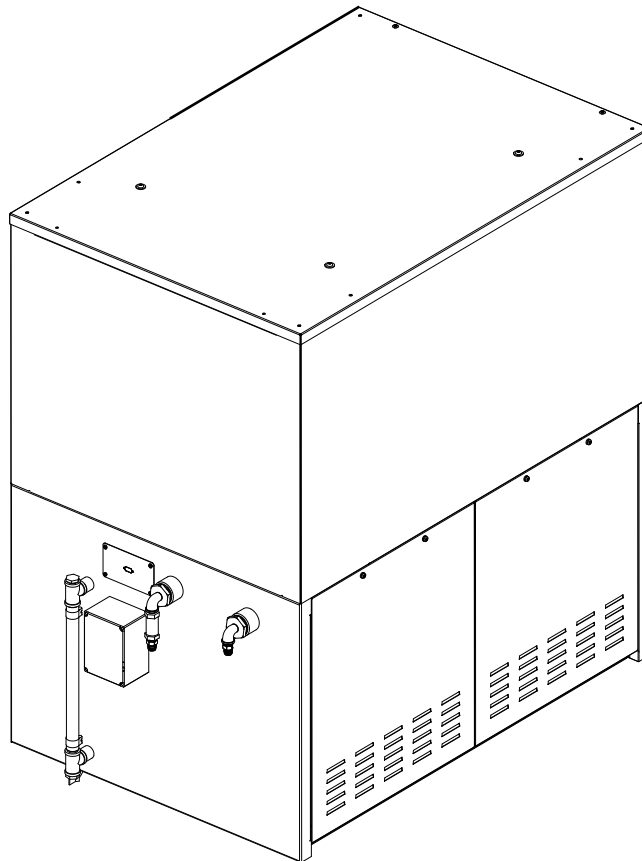

E Install the chiller interface console

- Mount the chiller interface console in a horizontal position.
- Allow room to remove the top for servicing.
- If the chiller interface console is placed on top of power supply, do not drill holes through the power supply cover to bolt it in place.

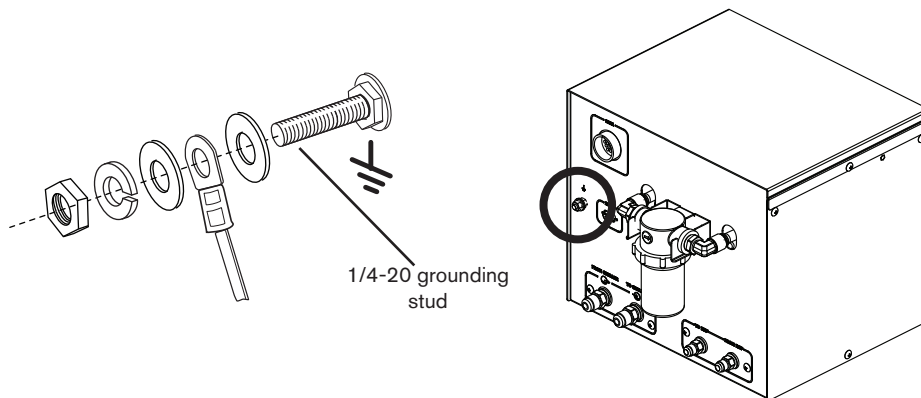
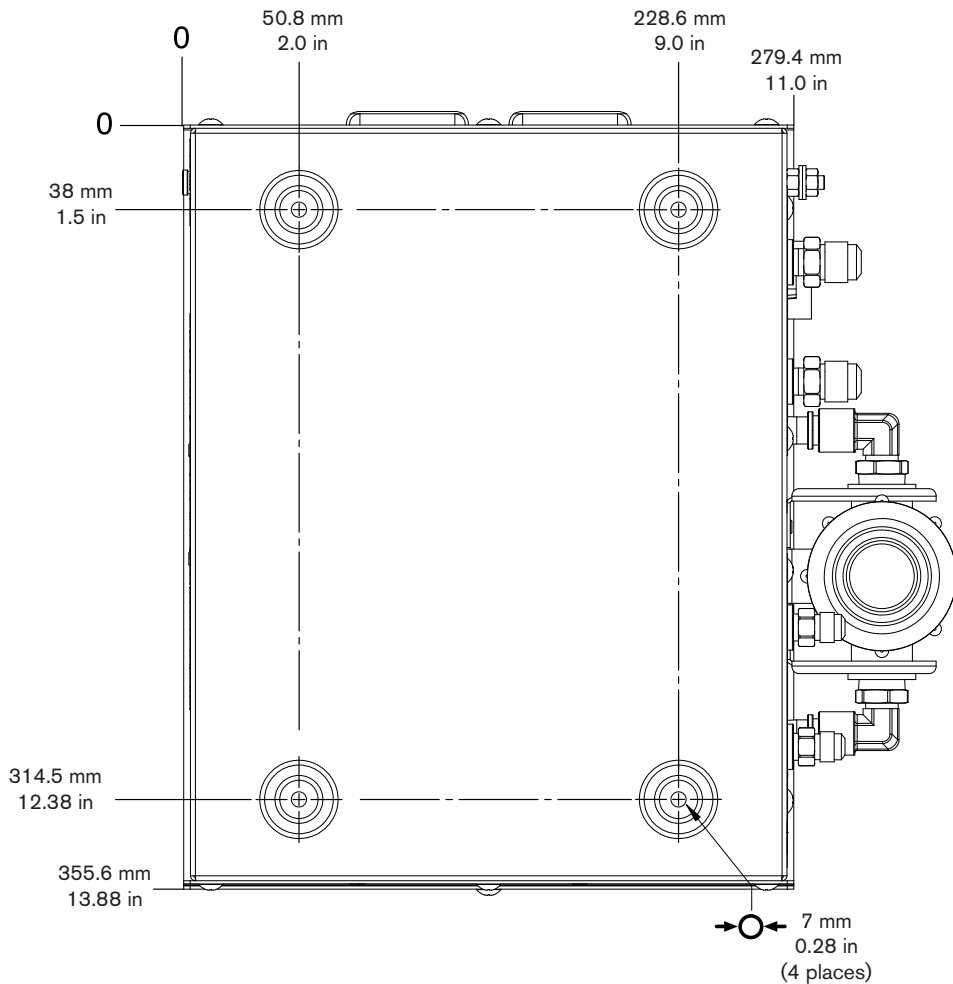

Ignition console grounding

F Install the metering console

- Mount the metering console near the torch lifter station. The maximum length of the gas hoses between the metering console and the torch is 1.8 m (6 ft).

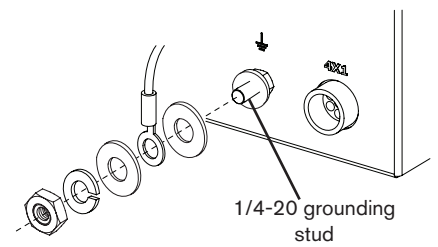
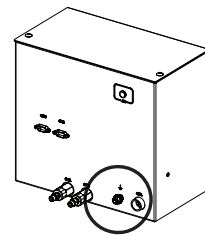
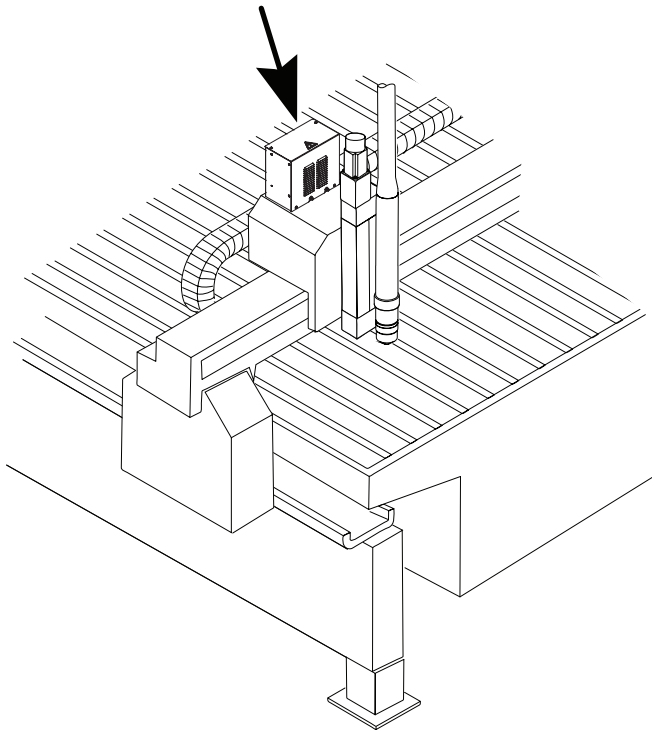

Metering console grounding

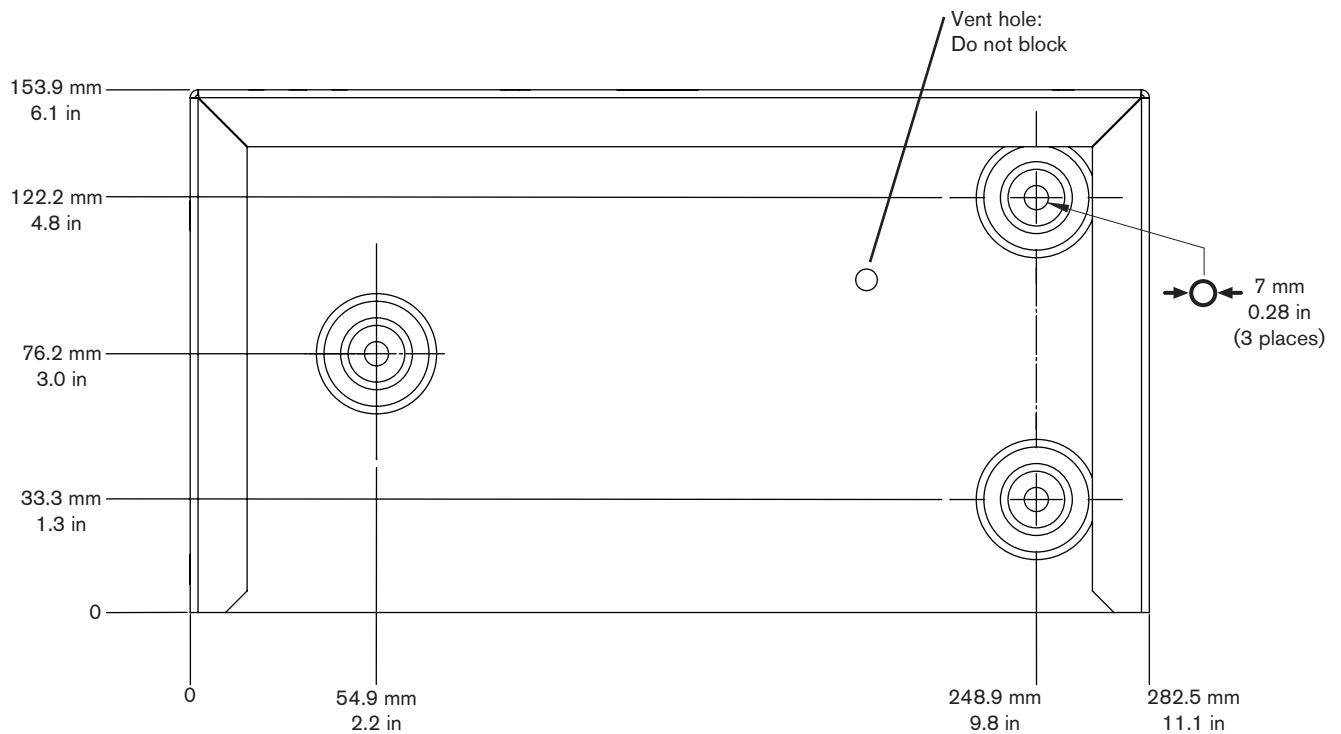

G Placement of the selection console

- Mount the selection console near the cutting table. Allow room to remove the top and right side cover for servicing. Preferred orientation is shown in the figure below. The maximum length of cables between the power supply and selection console is 75 m (250 ft). The maximum length of cables and hoses between the selection console and the metering console assembly is 20 m (65 ft).

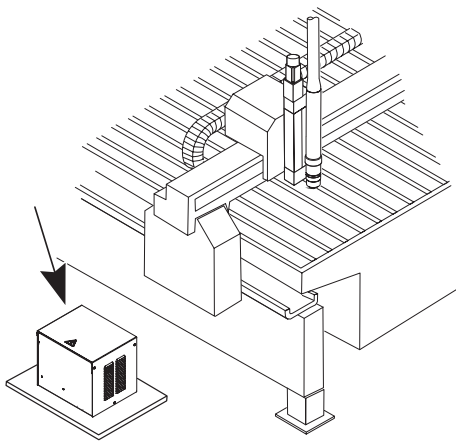

Preferred selection console orientation

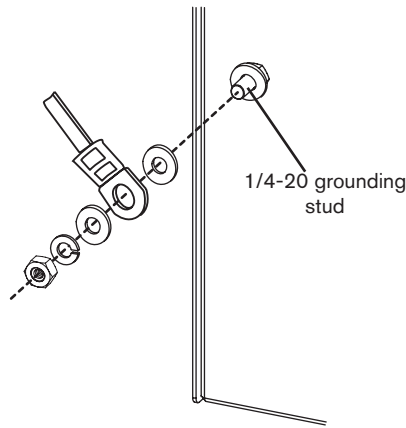

1/4-20 grounding stud

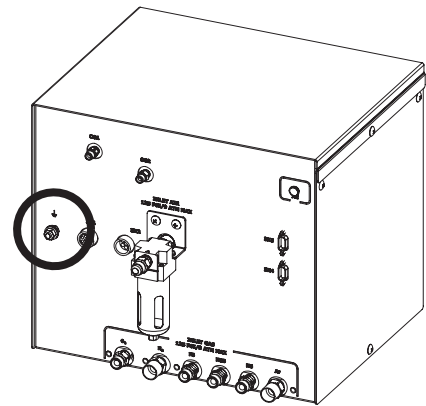

Selection console grounding

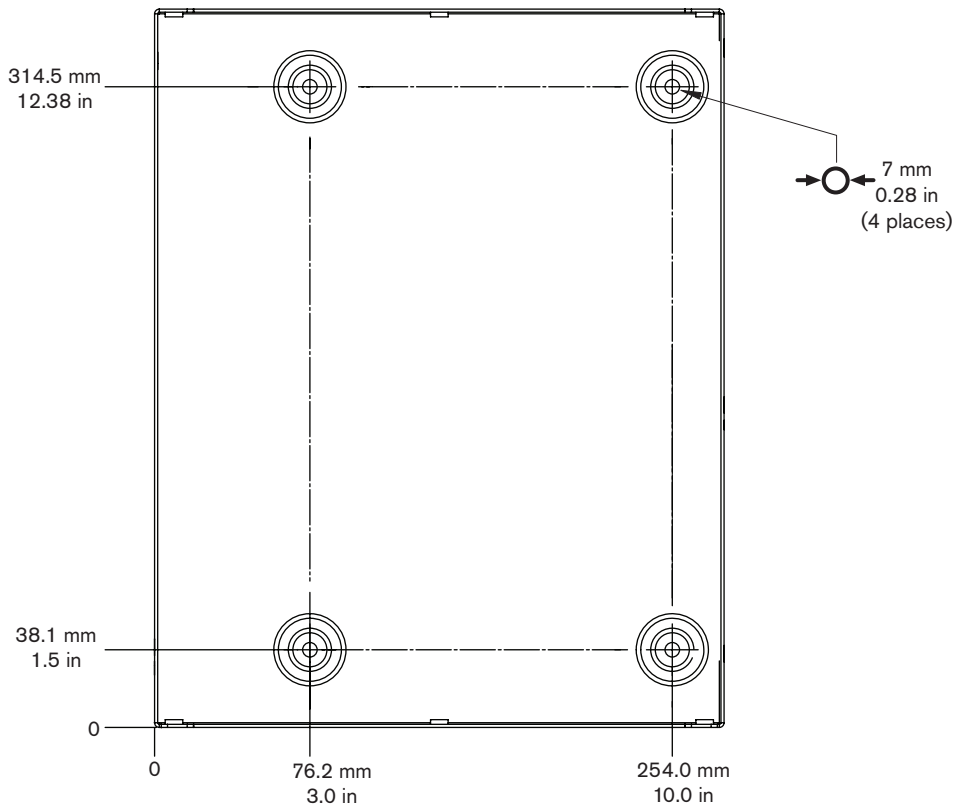

Primary power supply to secondary power supply cables

1 Interface (on/off) cable



Part no.	Length
223071	4.5 m (15 ft)
223098	7.5 m (25 ft)

Cable signal list – primary power supply to secondary power supply			
Primary power supply end		Secondary power supply end	
Wire color	Pin No.	Description	Pin No.
Red	1	120 VAC-hot	4
Black	2	120 VAC-return	5
Shield	3	Ground	6

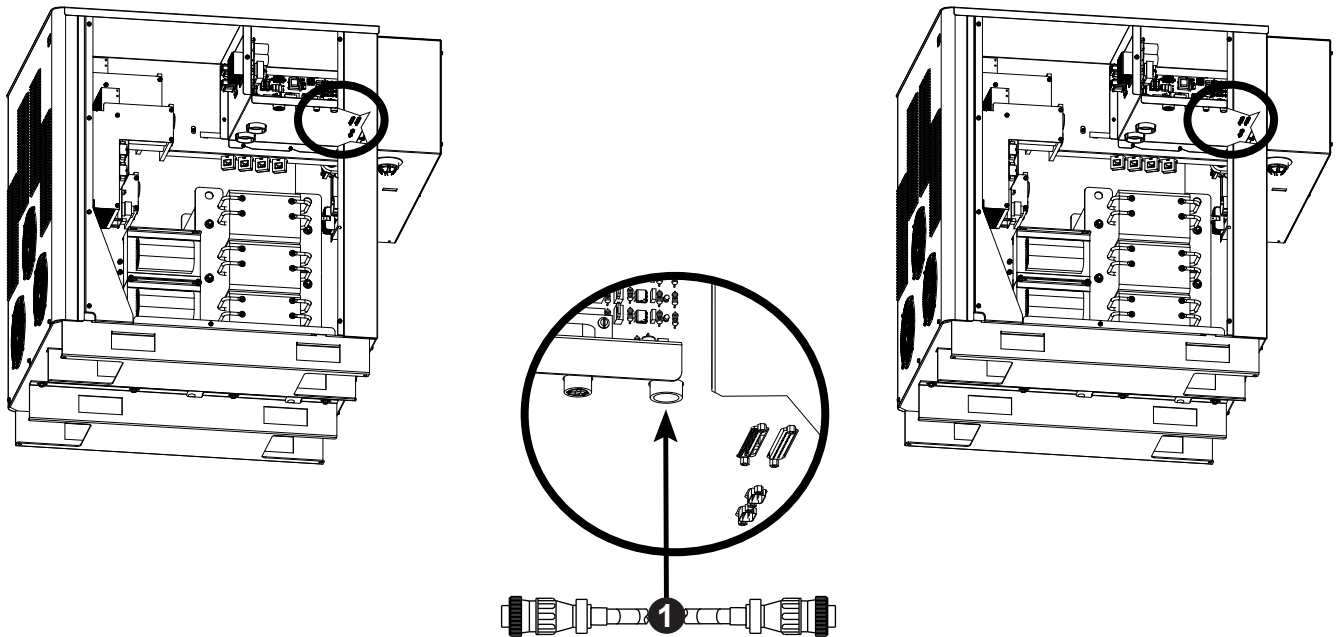

2 Communication cable

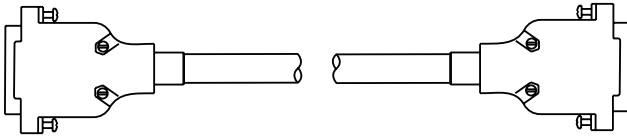

Part no.	Length
123839	4.5 m (15 ft)
123691	7.5 m (25 ft)

Cable signal list – power supply to power supply (9-pin DSUB connectors)						
Primary power supply end				Secondary power supply end		
Pin No.	Wire color	Input/Output	Description	Pin No.	Input/Output	Function
2	Black	Input/Output	CAN L	2	Input/Output	CAN communication
3	Black	Input	CAN ground	3	Output	Power ground
7	Red	Input/Output	CAN H	7	Input/Output	CAN communication
9	Red	Input	Not used	9	Output	Not used

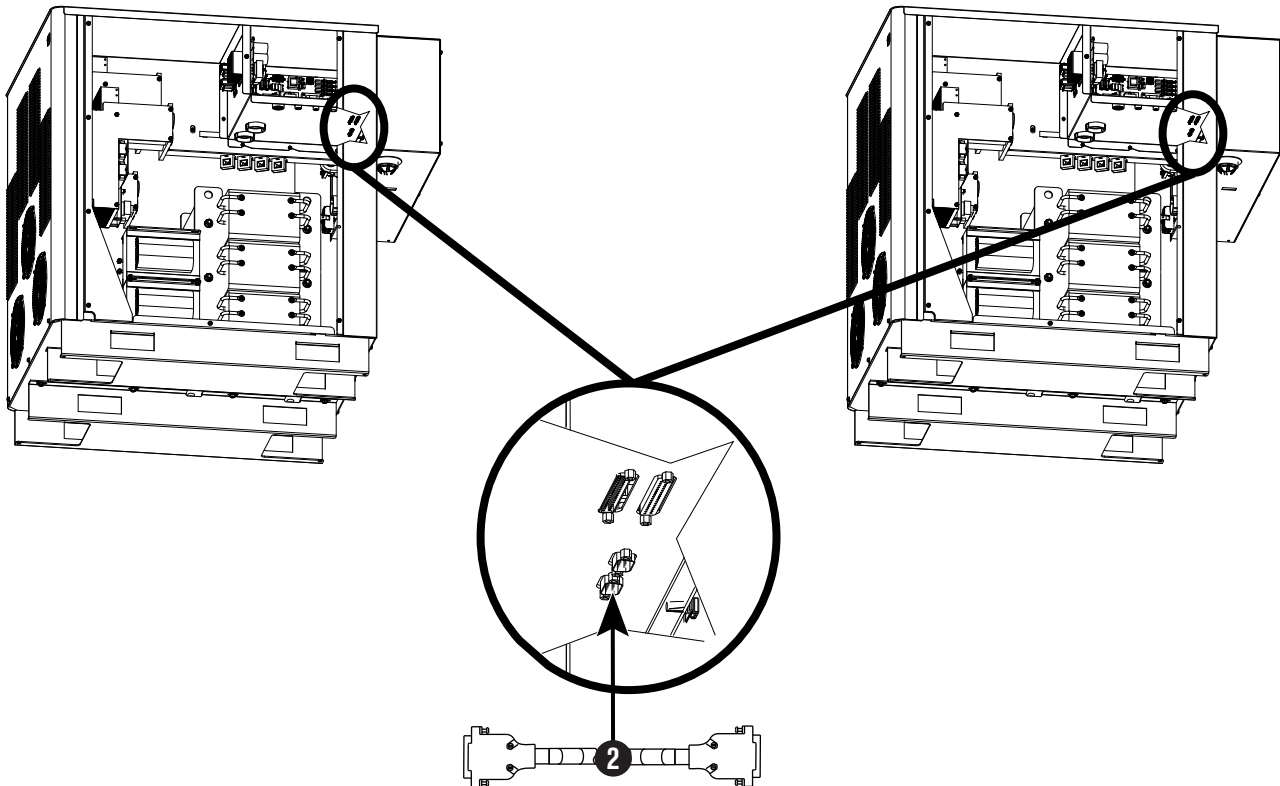

Power supply to ignition console leads

3 Pilot arc lead

*Note: The pilot arc lead only attaches between the primary power supply and the ignition console

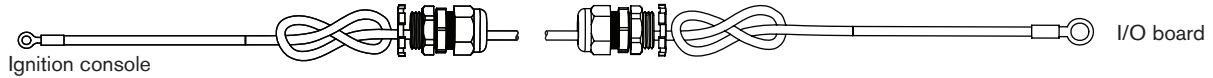

Part no.	Length	Part no.	Length
123820	3 m (10 ft)	123735	25 m (82 ft)
123821	4.5 m (15 ft)	123668	35 m (115 ft)
123666	7.5 m (25 ft)	123669	45 m (150 ft)
123822	10 m (35 ft)	123824	60 m (200 ft)
123667	15 m (50 ft)	123825	75 m (250 ft)
123823	20 m (65 ft)		

4 Negative leads

*Note: There is a negative lead between each power supply and the ignition console

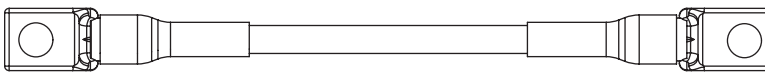

Part no.	Length	Part no.	Length
123418	3 m (10 ft)	123996	25 m (82 ft)
023382	4.5 m (15 ft)	123997	35 m (115 ft)
023078	7.5 m (25 ft)	023081	45 m (150 ft)
123994	10 m (35 ft)	023188	60 m (200 ft)
023079	15 m (50 ft)	023815	75 m (250 ft)
123995	20 m (65 ft)		

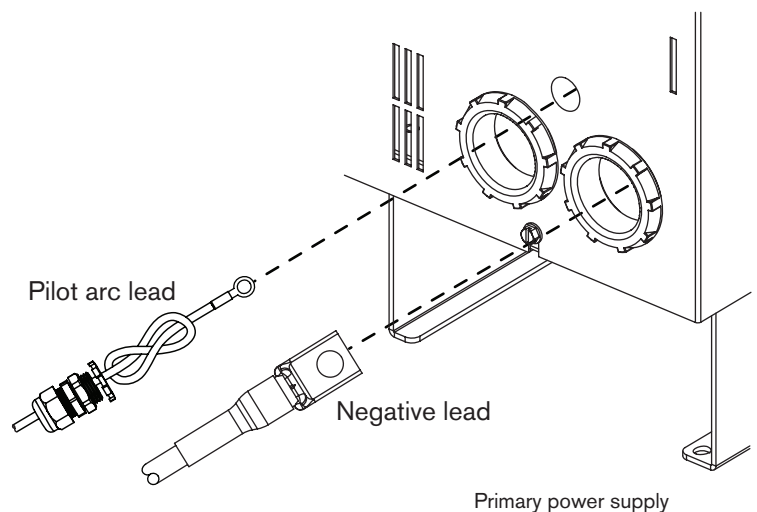
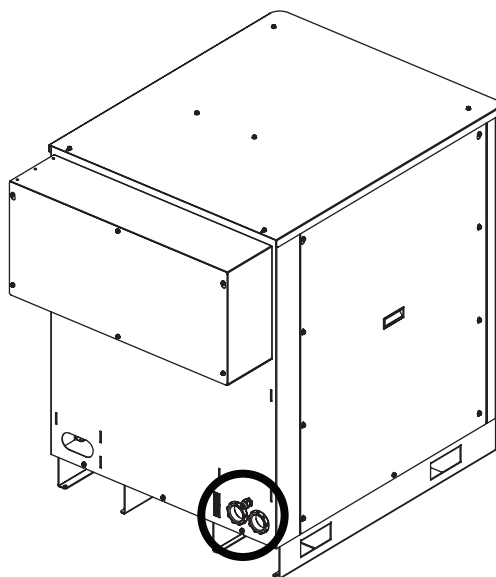

INSTALLATION

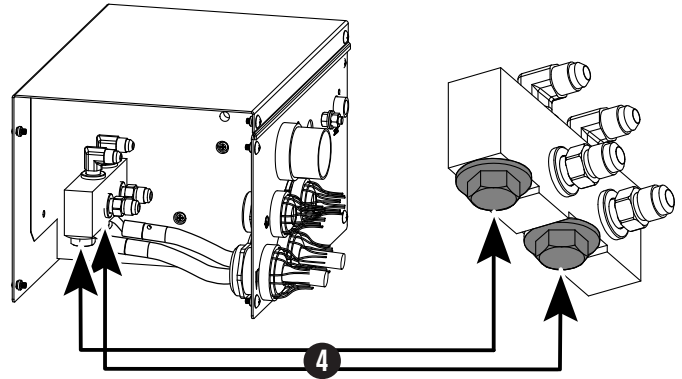
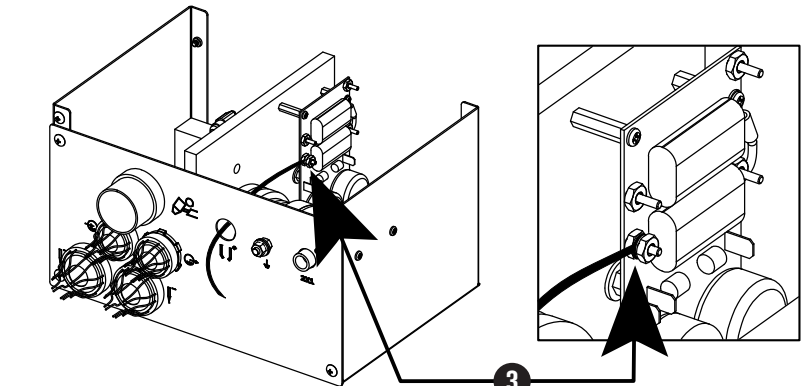
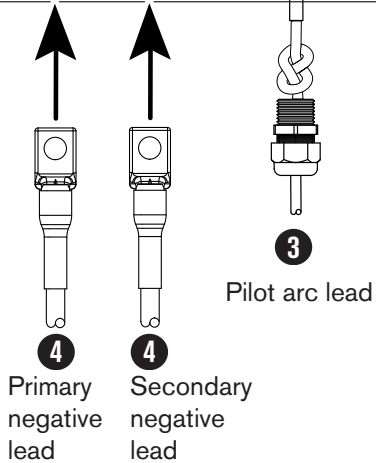
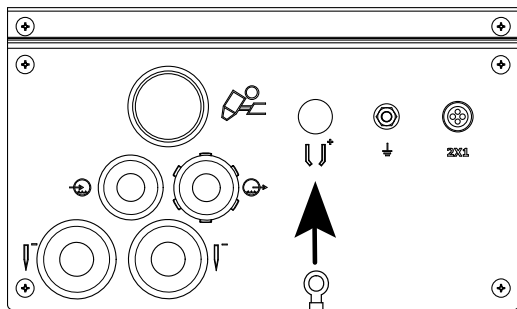
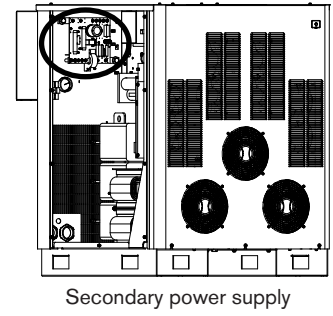
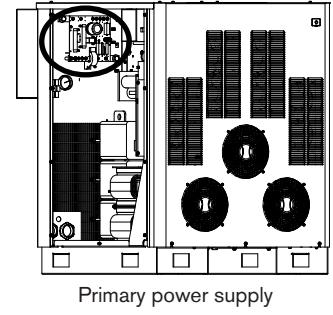
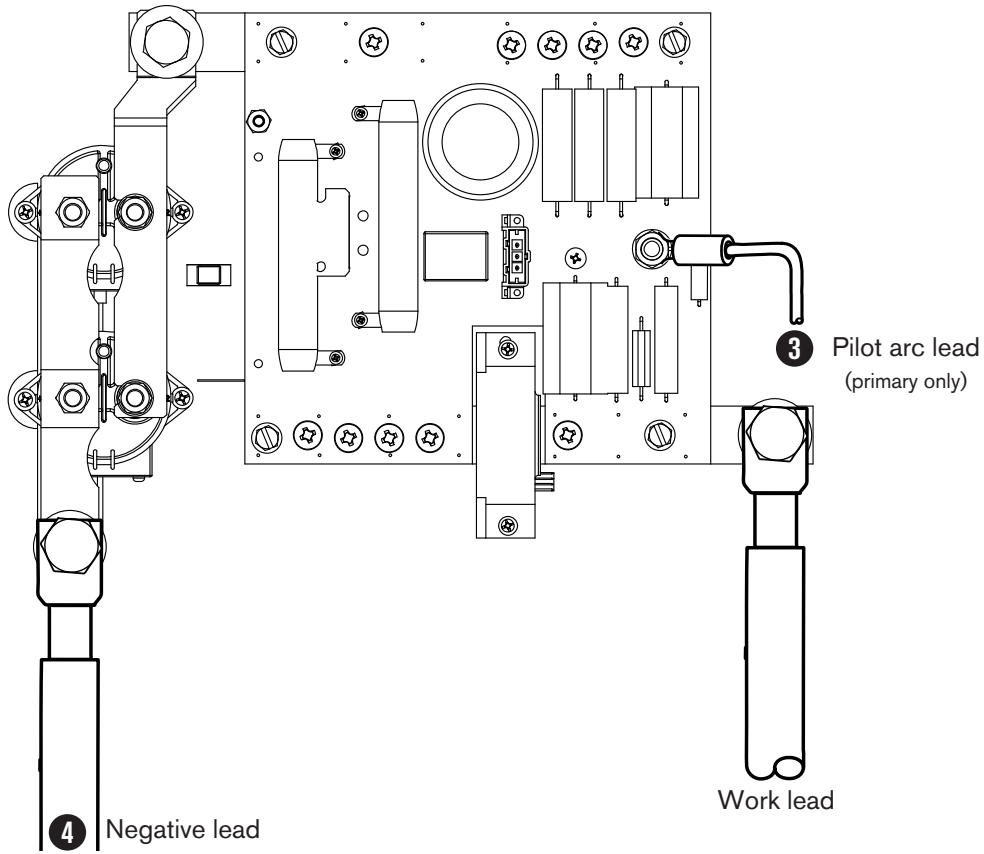

5 Ignition console power cable (from primary power supply)

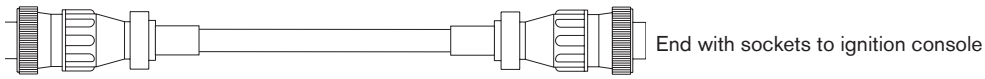

Part no.	Length	Part no.	Length
123419	3 m (10 ft)	123425	22.5 m (75 ft)
123834	4.5 m (15 ft)	123736	25 m (82 ft)
123420	6 m (20 ft)	123426	30 m (100 ft)
123670	7.5 m (25 ft)	123672	35 m (115 ft)
123422	9 m (30 ft)	123938	37.5 m (125 ft)
123835	10 m (35 ft)	123673	45 m (150 ft)
123423	12 m (40 ft)	123837	60 m (200 ft)
123671	15 m (50 ft)	123838	75 m (250 ft)
123836	20 m (65 ft)		

Cable signal list – power supply to ignition console		
Power supply end		Ignition console end
Pin No.	Description	Pin No.
1	120 VAC-hot	1
2	120 VAC-return	2
3	Ground	3
4	Not used	4

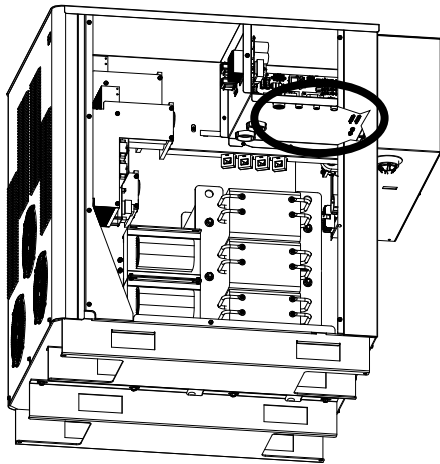

Primary power supply

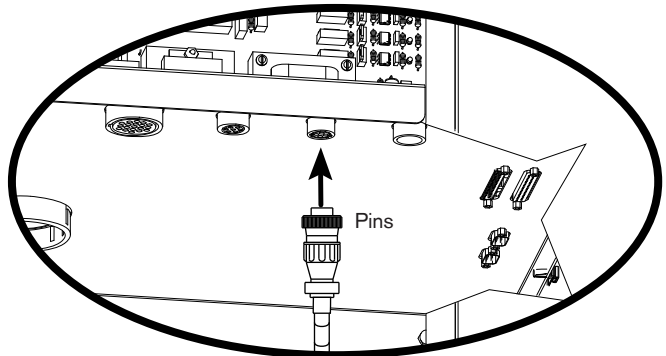

5

5

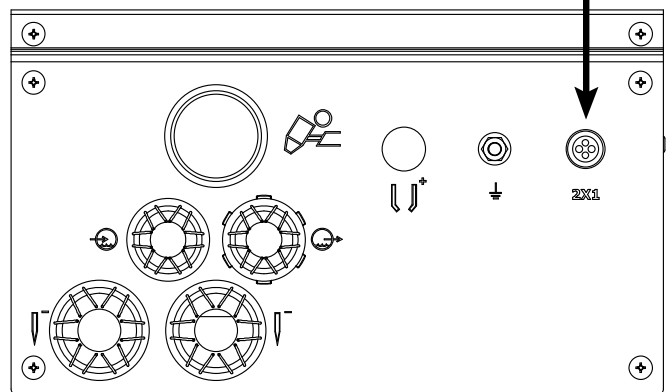
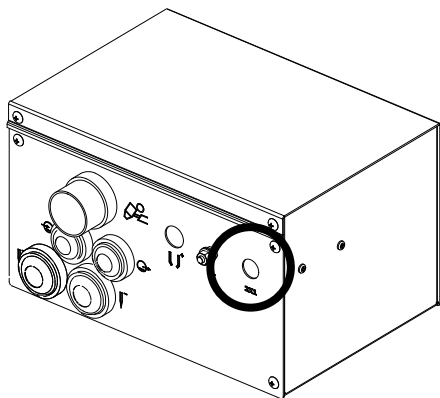
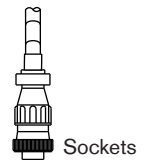

INSTALLATION

6 Coolant hose set (chiller to chiller-interface console)

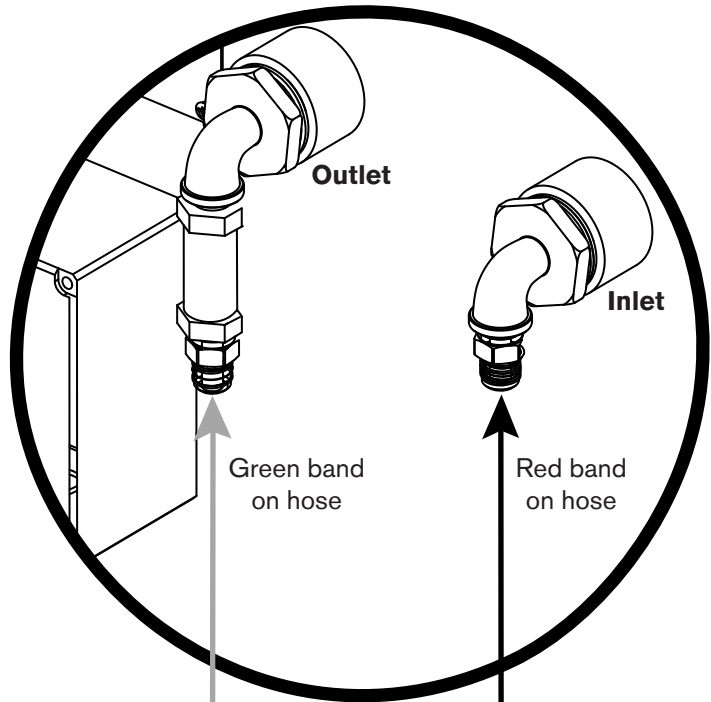
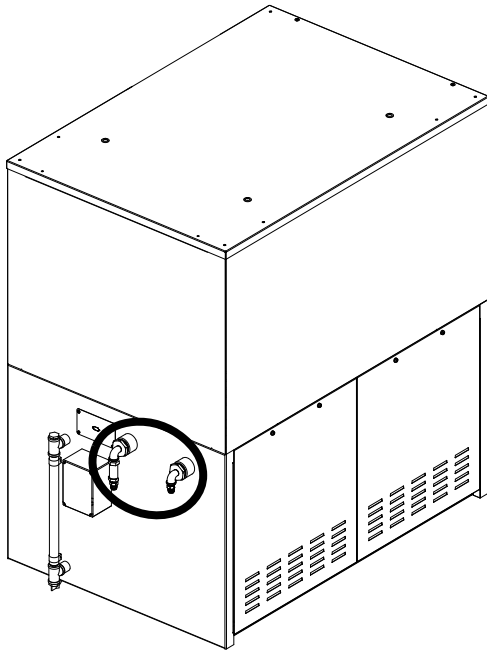

Part no.	Length
228540	4.5 m (15 ft)
228541	7.5 m (25 ft)
228542	15 m (50 ft)

Caution: Never use PTFE tape on any joint preparation.

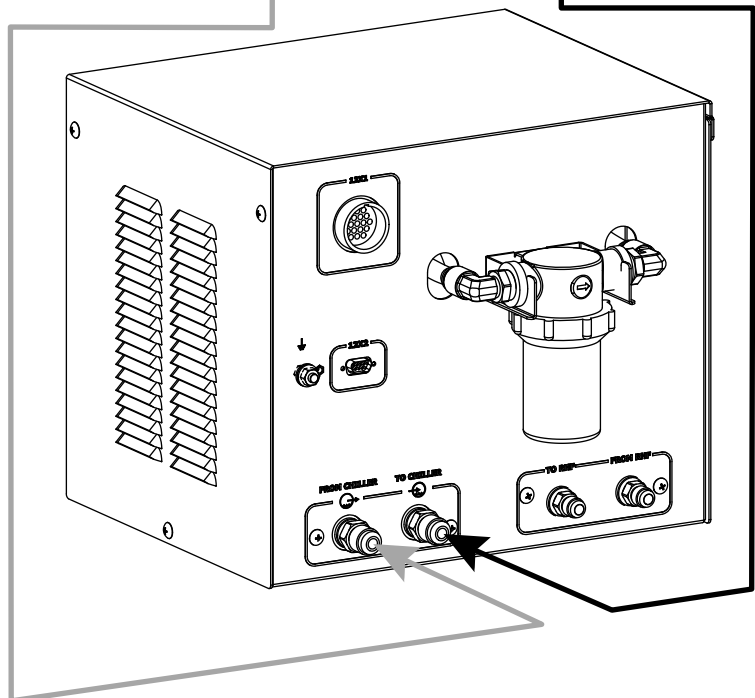

7 Coolant hose set (chiller-interface console to ignition console)

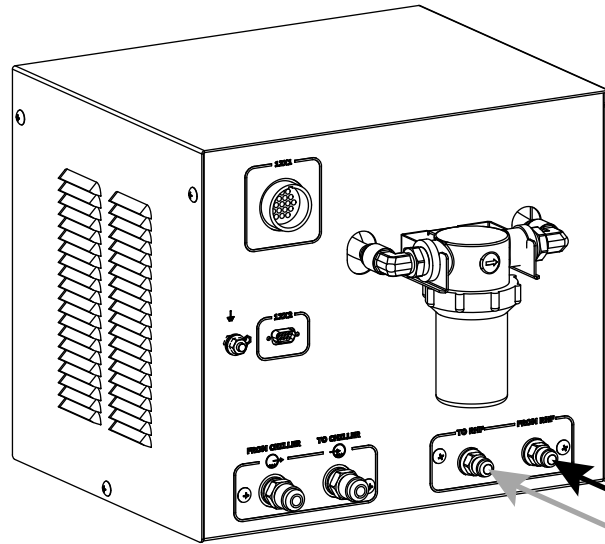

Green band
on hose

Red band
on hose

Part no.	Length	Part no.	Length
128499	1.5 m (5 ft)	128984	20 m (65 ft)
028652	3 m (10 ft)	128078	25 m (85 ft)
028440	4.5 m (15 ft)	028896	35 m (115 ft)
028441	7.5 m (25 ft)	028445	45 m (150 ft)
128173	10 m (35 ft)	028637	60 m (200 ft)
028442	15 m (50 ft)	128985	75 m (250 ft)

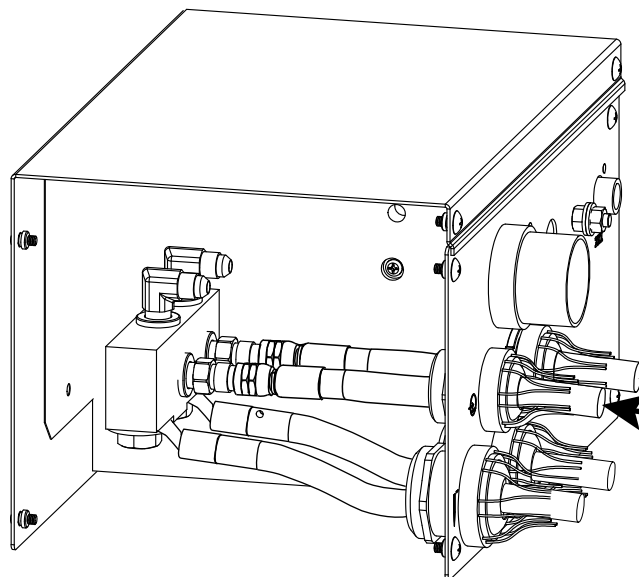
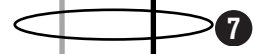

Primary power supply to chiller interface console

8 Chiller interface power cable

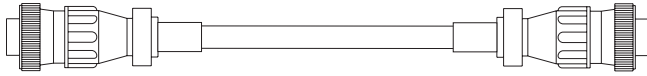

End with sockets to chiller interface

Part no.	Length
123979	1.5 m (5 ft)
123980	3 m (10 ft)
123981	4.5 m (15 ft)

Cable signal list – primary power supply to chiller interface			
Power supply end			Chiller interface end
Pin No.	Wire color	Description	Pin No.
1	Red/black	240 VAC-hot	1
2	Red	240 VAC-return	2
3	Shield	Ground	3
15	White	Solenoid V1- return	15
11	Black	Solenoid V1- hot	11
6	Shield	Ground	6

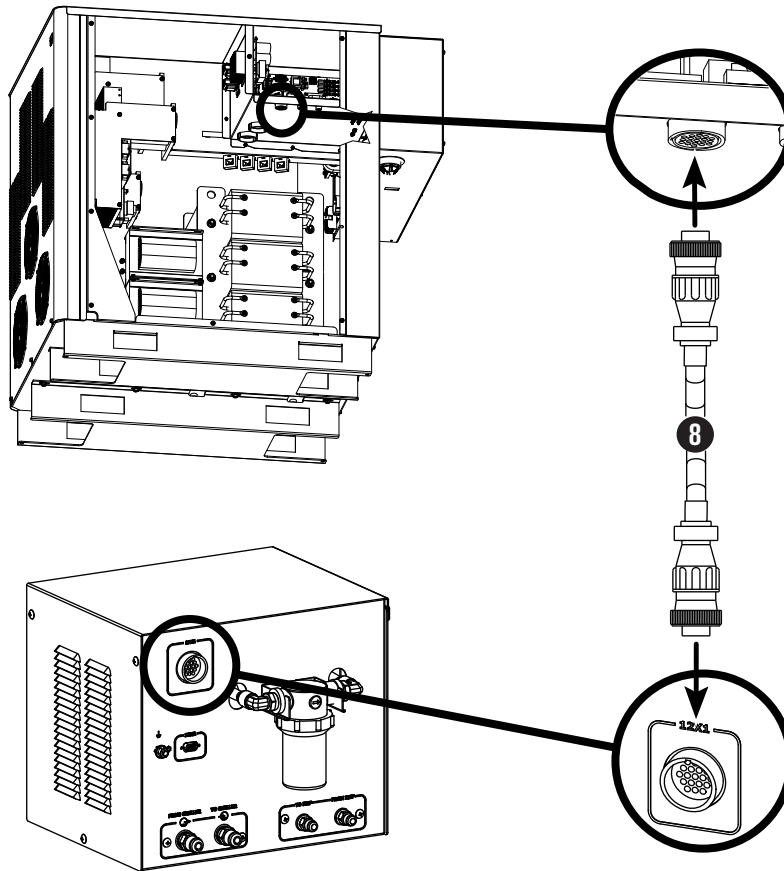

Note: The inductor on the pump motor drive board makes a noise during operation that has been described as a “hum”, “sing”, and “click”. This is normal and can be disregarded.

Secondary power supply to chiller interface console

9 Chiller interface communication cable

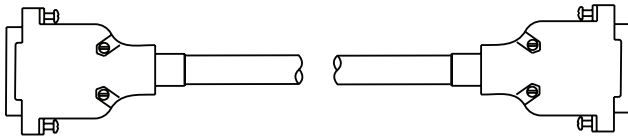

End with sockets to chiller interface

Part no.	Length
123844	1.5 m (5 ft)
123784	3 m (10 ft)
123839	4.5 m (15 ft)

Cable signal list – secondary power supply to chiller interface (9-pin DSUB connectors)						
Power supply end				Chiller interface end		
Pin No.	Wire color	Input/Output	Description	Pin No.	Input/Output	Function
2	Black	Input/Output	CAN L	2	Input/Output	CAN communication
3	Black	Input	CAN ground	3	Output	Power ground
7	Red	Input/Output	CAN H	7	Input/Output	CAN communication
9	Red	Output	Not used	9	Output	Not used

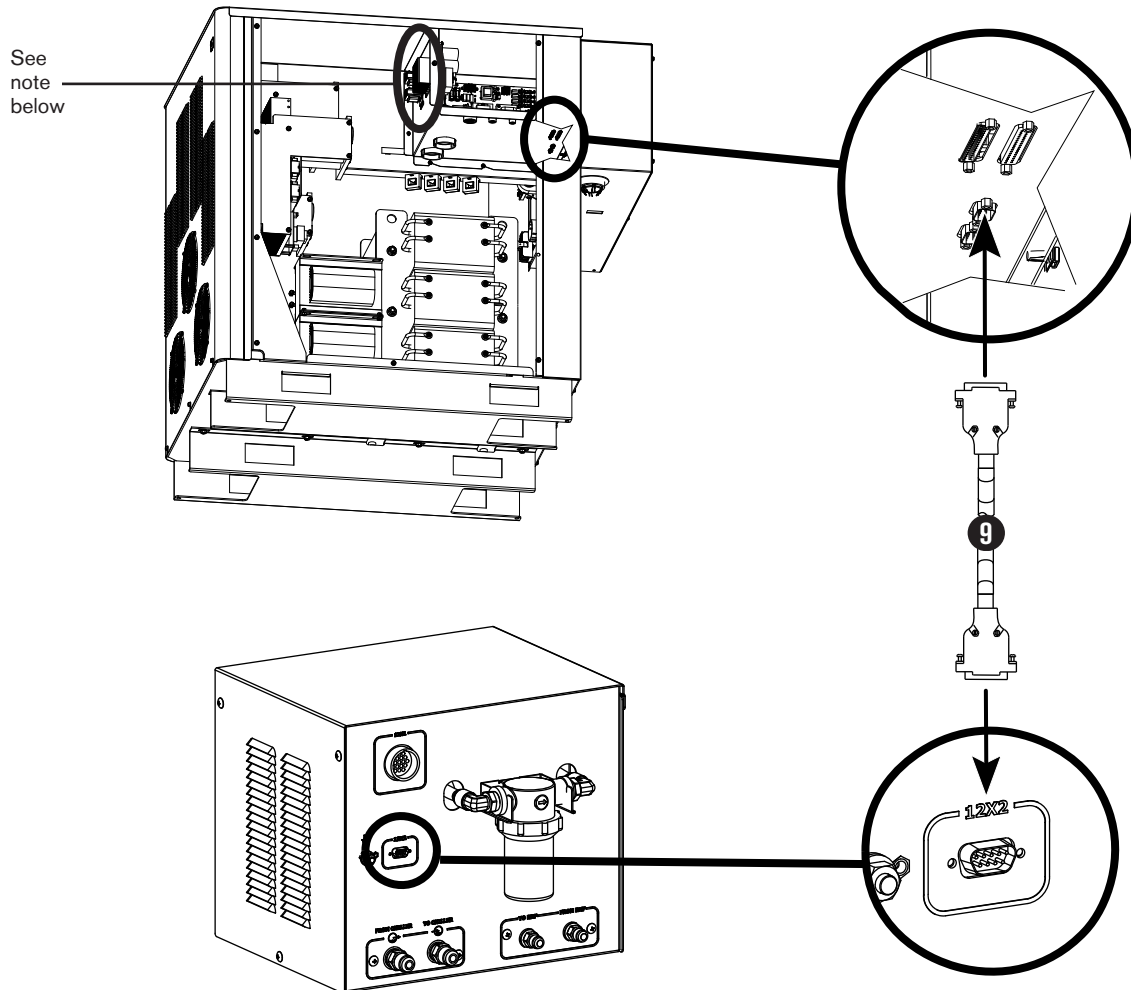

Primary Power supply to selection console cables

10 Selection console communication cable

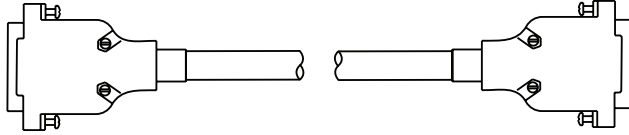

Part no.	Length	Part no.	Length
123784*	3 m (10 ft)	123841	20 m (65 ft)
123839	4.5 m (15 ft)	123737	25 m (82 ft)
123963	6 m (20 ft)	123738	35 m (115 ft)
123691	7.5 m (25 ft)	123739	45 m (150 ft)
123840	10 m (35 ft)	123842	60 m (200 ft)
123711	15 m (50 ft)	123843	75 m (250 ft)

Cable signal list – primary power supply to selection console (9-pin DSUB connectors)						
Power supply end				Selection console end		
Pin No.	Wire color	Input/Output	Description	Pin No.	Input/Output	Function
2	Black	Input/Output	CAN L	2	Input/Output	CAN communication
3	Black	Input	CAN ground	3	Output	Power ground
7	Red	Input/Output	CAN H	7	Input/Output	CAN communication
9	Red	Output	Not used	9	Output	Not used

11 Selection console power cable



Part no.	Length	Part no.	Length
123785*	3 m (10 ft)	123848	20 m (65 ft)
123846	4.5 m (15 ft)	123740	25 m (82 ft)
123964	6 m (20 ft)	123676	35 m (115 ft)
123674	7.5 m (25 ft)	123677	45 m (150 ft)
123847	10 m (35 ft)	123849	60 m (200 ft)
123675	15 m (50 ft)	123850	75 m (250 ft)

Cable signal list – primary power supply to gas console		
Power supply end	Description	Gas console end
Pin No.		Pin No.
1	120 VAC-hot	1
2	120 VAC-return	2
3	Ground	3
4	Not used	4
5	Not used	5
6	24 VAC-hot	6
7	24 VAC-return	7

* Cable numbers 123784 and 123785 are for use with systems that have the gas console mounted on the power supply

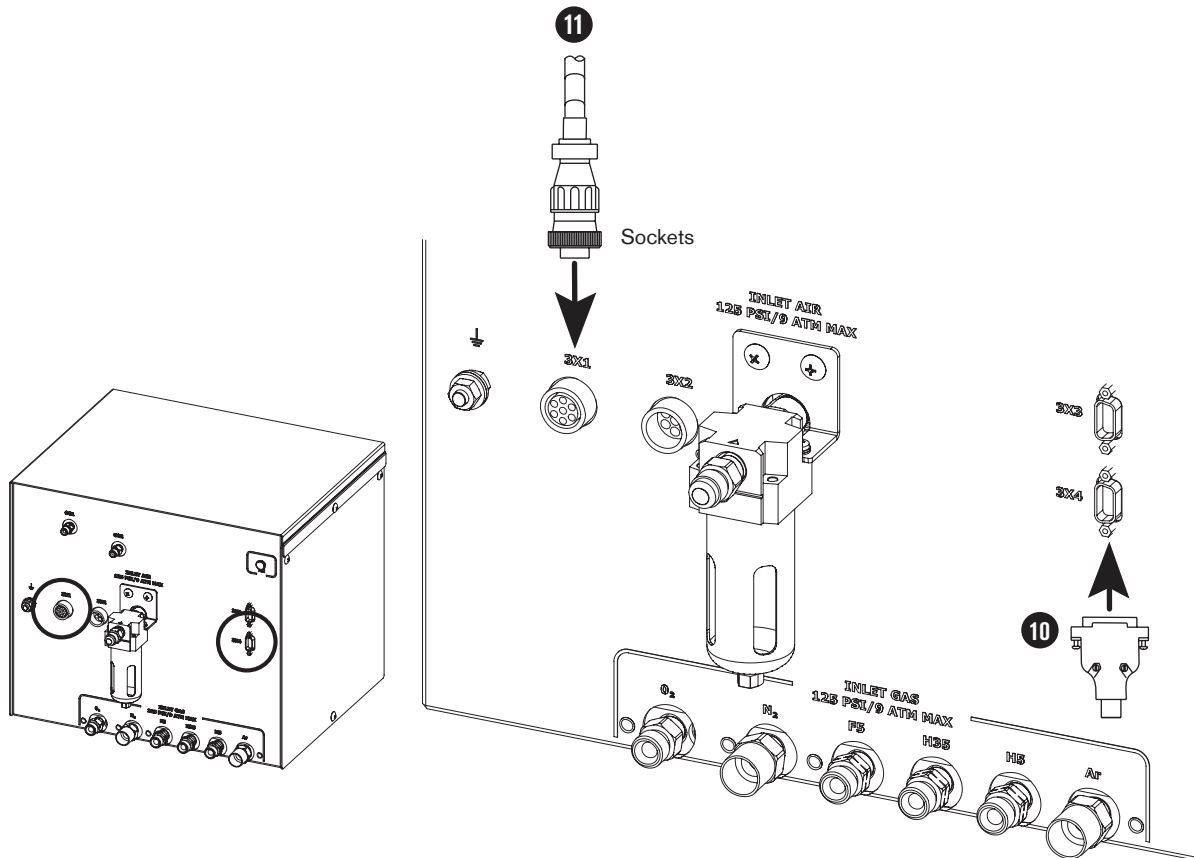
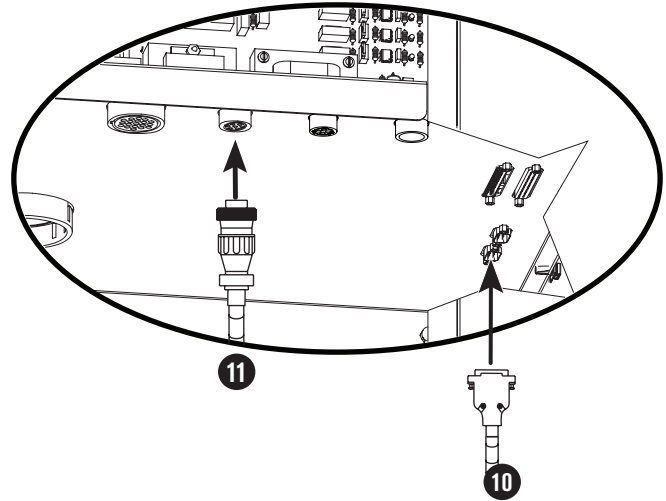
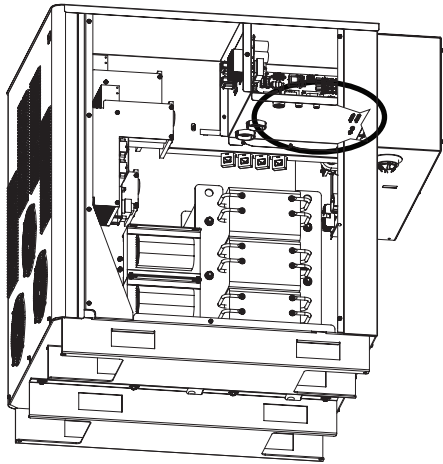

Selection console to metering console hose and lead assembly

12 Cable and gas hose assembly

Part no.	Length
128992	3 m (10 ft)
128993	4.5 m (15 ft)
228338	6 m (20 ft)
128952	7.5 m (25 ft)
128994	10 m (35 ft)
128930	15 m (50 ft)
128995	20 m (65 ft)

Power cable signal list – 9-pin connectors					
Metering console end			Selection console end		
Pin No.	Input/Output	Description	Pin No.	Input/Output	Function
1	Input	120 VAC power	1	Output	AC in, return
2	Input	120 VAC power	2	Output	AC in, hot
3	Input	Chassis ground	3	Output	Chassis ground
4		Not used	4		Not used
5		Not used	5		Not used
6		Not used	6		Not used
7		Not used	7		Not used

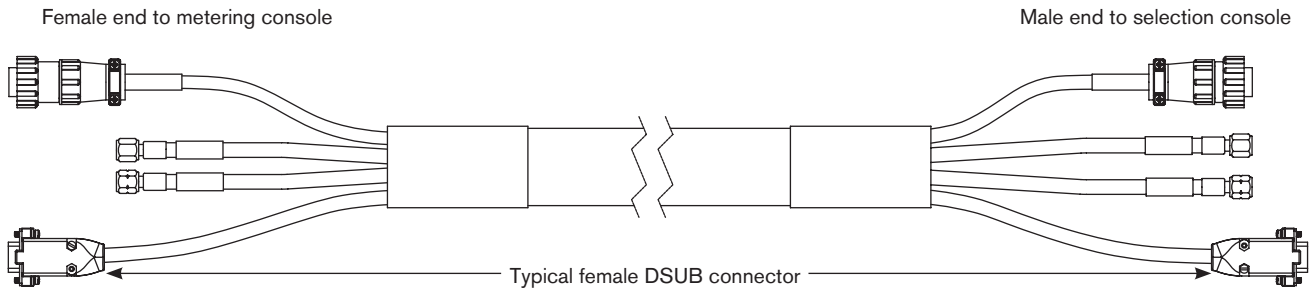

Communication cable signal list – 9-pin DSUB connectors					
Metering console end			Selection console end		
Pin No.	Input/Output	Description	Pin No.	Input/Output	Function
2	Input/Output	CAN L	2	Input/Output	CAN communication
3	Input	CAN ground	3	Output	Power ground
7	Input/Output	CAN H	7	Input/Output	CAN communication
9	Input	Not used	9	Output	Not used

Caution: Never use PTFE tape on any joint preparation.

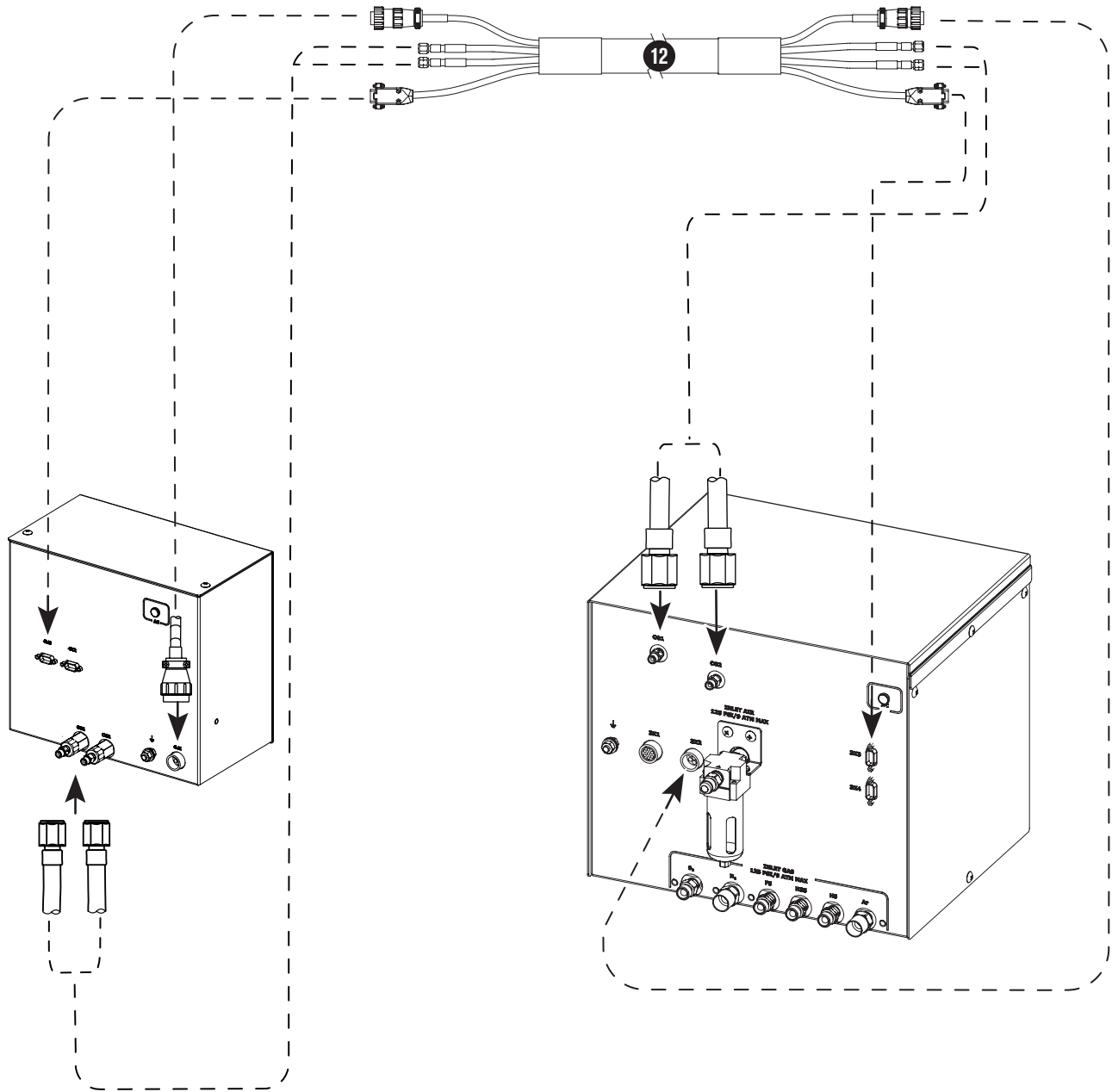

INSTALLATION

13 Power supply to CNC interface cable

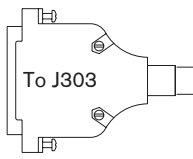

Part no.	Length	Part no.	Length	Part no.	Length
123210	3 m (10 ft)	123216	13.5 m (45 ft)	123742	35 m (115 ft)
123211	4.5 m (15 ft)	123023	15 m (50 ft)	123219	37.5 m (125 ft)
123212	6 m (20 ft)	123494	16.5 m (55 ft)	123220	45 m (150 ft)
123022	7.5 m (25 ft)	123851	20 m (65 ft)	123852	60 m (200 ft)
123213	9 m (30 ft)	123217	22.5 m (75 ft)	123853	75 m (250 ft)
123214	10 m (35 ft)	123741	25 m (82 ft)		
123215	12 m (40 ft)	123218	30 m (100 ft)		

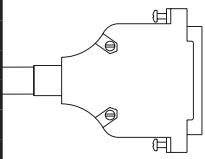

14 Optional multi-system CNC interface cable (see schematics for installation information)

Power supply end				CNC end		
Wire color	Pin no.	Input/ Output	Signal name	Function	Input/ Output	Notes
Black	1	Input	RX -	RS-422 serial receiver	Output	
Red	20	Input	RX +	RS-422 serial receiver	Output	
Black	2	Output	TX -	RS-422 serial transmitter	Input	
Green	21	Output	TX +	RS-422 serial transmitter	Input	
Black	3		RS-422 ground	RS-422 serial ground		
Blue	22		None	Not used		
Black	4	Output	Motion 1 E (-)	Notifies the CNC that an arc transfer has occurred and to begin machine motion once the CNC's pierce delay has timed out	Input	2 & 3
Yellow	23	Output	Motion 1 C (+)		Input	
Black	5	Output	Error E (-)	Notifies the CNC that an error has occurred	Input	2
Brown	24	Output	Error C (+)		Input	
Black	6	Output	Rampdown error E (-)	Notifies the CNC that a rampdown error has occurred	Input	2
Orange	25	Output	Rampdown error C (+)		Input	
Red	7	Output	Not ready E (-)	Notifies the CNC that the plasma system is not ready to fire an arc	Input	2
White	26	Output	Not ready C (+)		Input	
Red	8	Output	Motion 2 E (-)	Notifies the CNC that an arc transfer has occurred and to begin machine motion once the CNC's pierce delay has timed out	Input	2 & 3
Green	27	Output	Motion 2 C (+)		Input	
Red	9	Output	Motion 3 E (-)	Notifies the CNC that an arc transfer has occurred and to begin machine motion once the CNC's pierce delay has timed out	Input	2 & 3
Blue	28	Output	Motion 3 C (+)		Input	
Red	10	Output	Motion 4 E (-)	Notifies the CNC that an arc transfer has occurred and to begin machine motion once the CNC's pierce delay has timed out	Input	2 & 3
Yellow	29	Output	Motion 4 C (+)		Input	
Red	11		None	Not used		
Brown	30		None	Not used		
Red	12	Input	Corner (-)	The CNC Notifies the plasma system that a corner is approaching and to reduce cut current (Cut current is CNC selectable or defaults to 50% of cut current)	Output	1
Orange	31	Input	Corner (+)		Output	
Green	13	Input	Pierce (-)	The CNC Notifies the plasma system to maintain the shield preflow until the CNC releases the signal	Output	1
White	32	Input	Pierce (+)		Output	
Green	14	Input	Hold (-)	Not required without CommandTHC. CommandTHC requires signal to preflow gases during IHS	Output	1
Blue	33	Input	Hold (+)		Output	
Green	15	Input	Start (-)	The CNC initiates the plasma arc	Output	1
Yellow	34	Input	Start (+)		Output	
Green	16		None	Not used		
Brown	35		None	Not used		
Green	17		None	Not used		
Orange	36		Power ground	Ground		
White	18		Power ground	Ground Available 24 VDC (200 milliamps maximum) see notes		4
Black	37		CNC +24 VDC			
	19		CNC +24 VDC	Not connected		

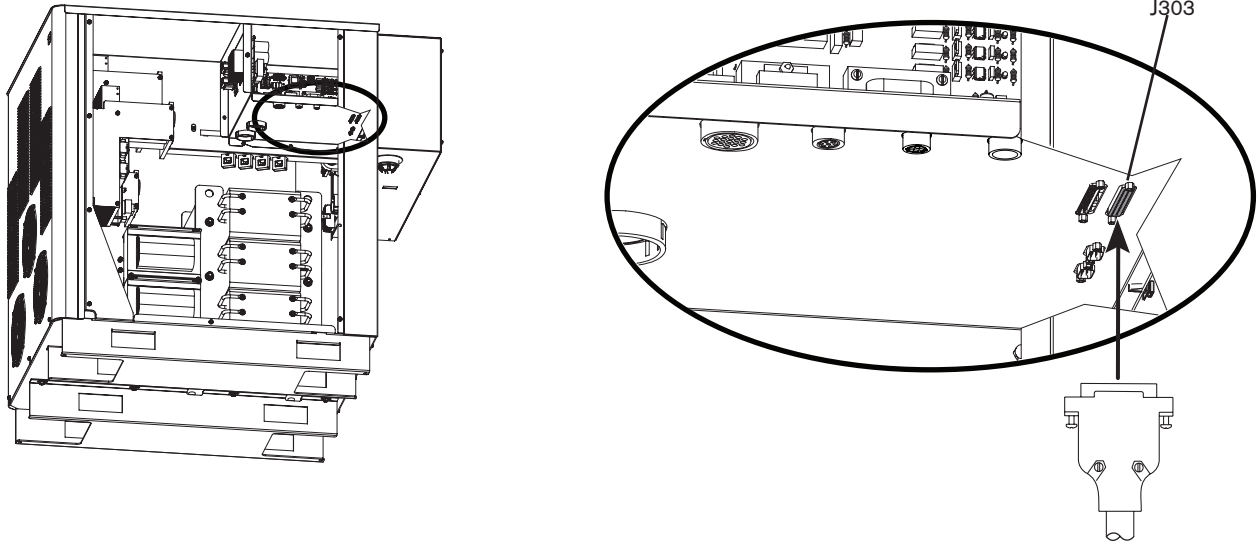

Notes to CNC interface cable run list

- Note 1. Inputs are optically isolated. They require 24 VDC at 7.3 mA, or dry-contact closure. The external relay's life may be improved by adding a metallized-polyester capacitor (0.022 μ F 100 V or higher) in parallel with the relay contacts.
- Note 2. Outputs are optically isolated, open collector, transistors. The maximum rating is 24 VDC at 10 mA.
- Note 3. Machine motion is selectable and is used for configurations with multiple plasma systems.
- Note 4*. CNC +24 VDC provides 24 VDC at 200 mA maximum. A jumper is required on J301 to use 24 V power.



Caution: The CNC cable must be constructed using cable with 360 degree shielding and metal housing connectors at each end. The shielding must be terminated to the metal housings at each end to ensure proper grounding and to provide the best shielding.

* See examples on pages 3-36 and 3-37

Examples of output circuits

1. Logic interface, active-high

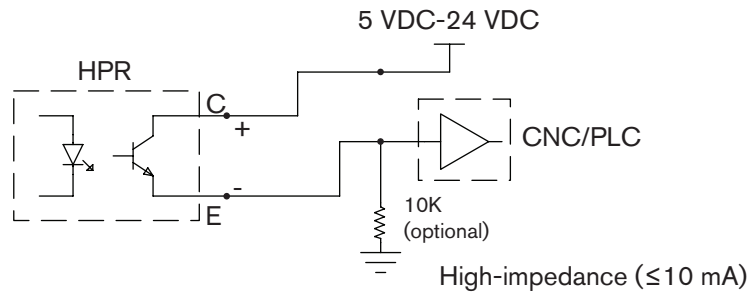

2. Logic interface, active-low

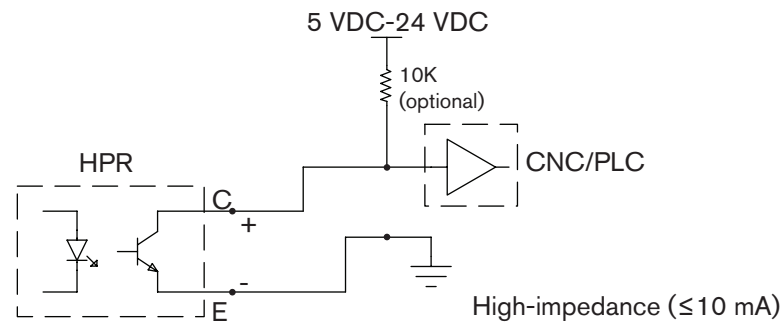

3. Relay interface

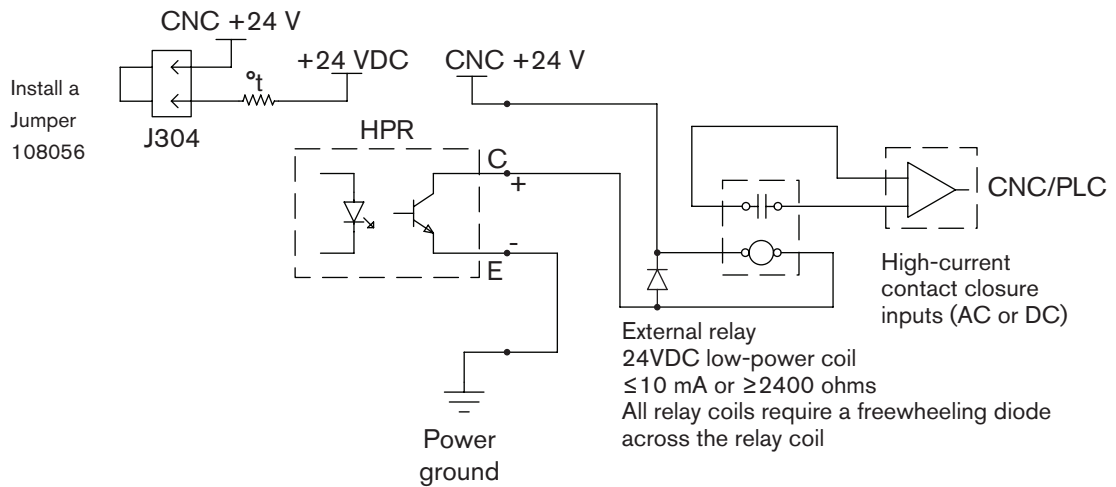

4. Do not use this configuration. Warranty will be void.

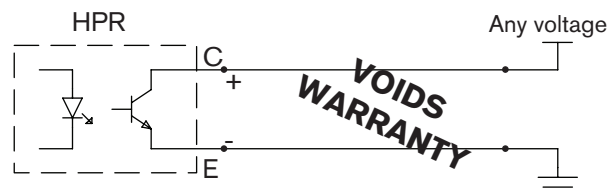

Examples of input circuits

1. Relay interface

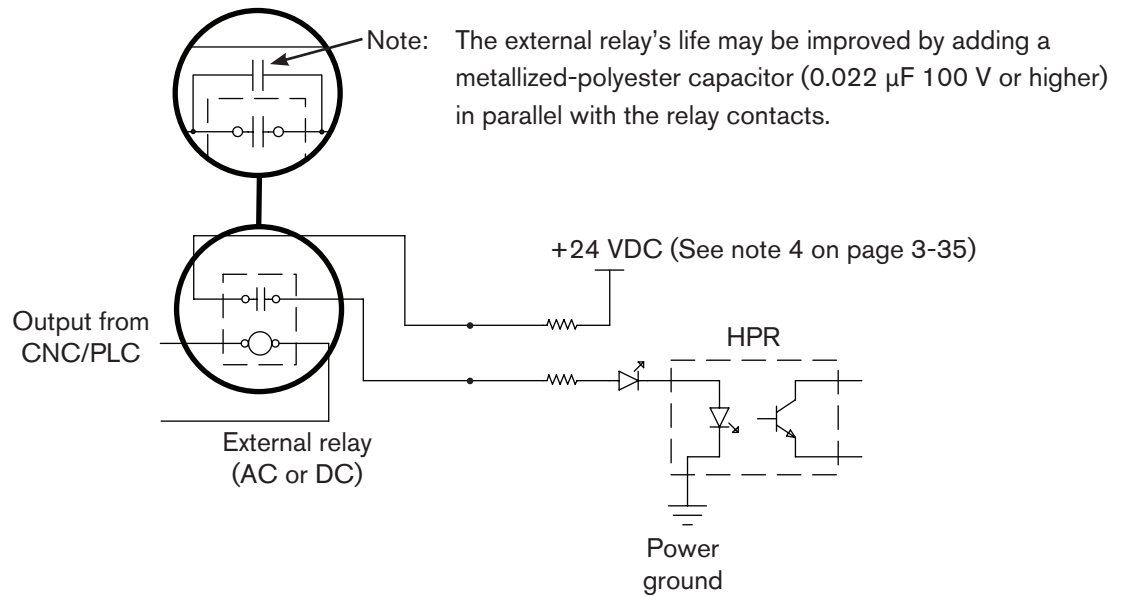

2. Optocoupler interface

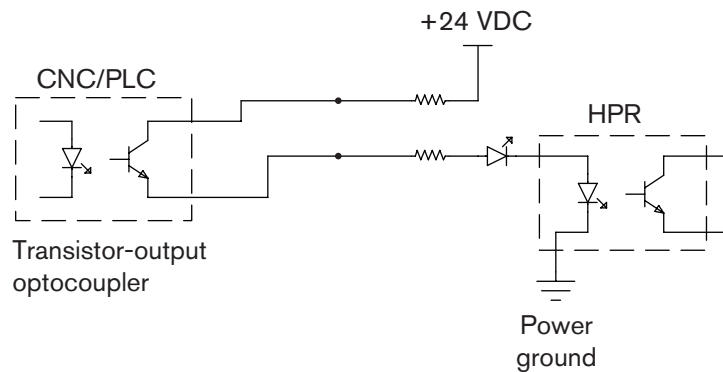

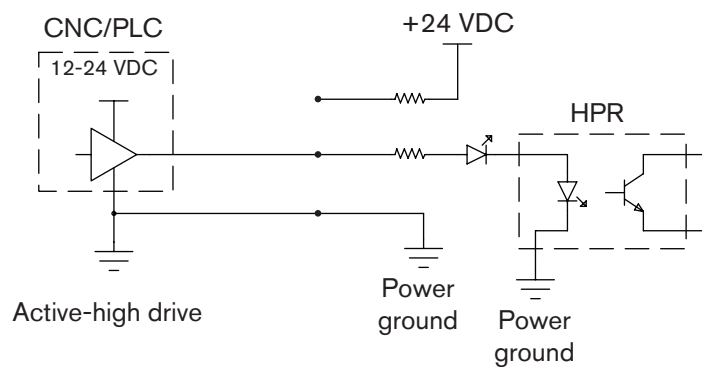

3. Amplified-output interface



INSTALLATION

Remote ON/OFF switch (provided by customer)

		<p style="text-align: center;">DANGER ELECTRIC SHOCK CAN KILL</p>
<p style="text-align: center;">Disconnect electrical power before performing any maintenance. See the <i>Safety Section</i> in this Manual for more safety precautions.</p>		

1. Locate terminal block 2 (TB2) in the power supply.

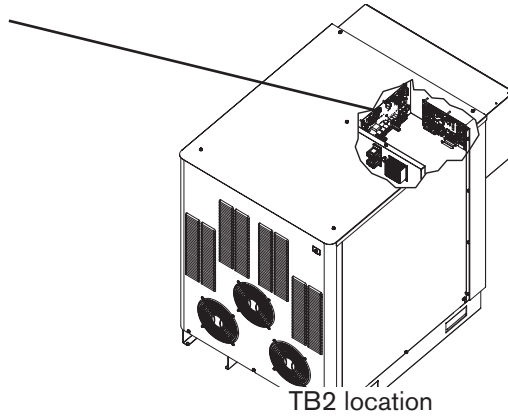

2. Remove wire 1 and wire 3 as shown. These wires do not need to be reconnected.

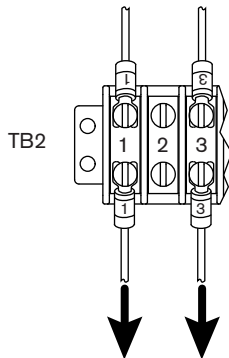

3. Connect switch to terminals 1 and 3 as shown.

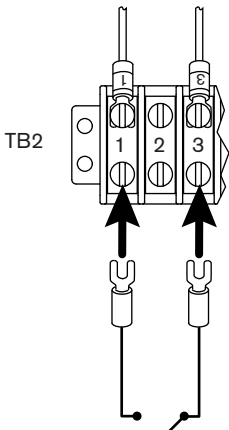



Note: Use a switch, relay or solid-state relay that is compatible with 24 VAC @ 100 mA. It must be a maintained contact switch, not a momentary contact switch.

15 Torch lead assembly

Part no.	Length
228291	2 m (6 ft)
228292	3 m (10 ft)
228293	4.5 m (15 ft)
228294	6 m (20 ft)
228295	7.5 m (25 ft)
228296	10 m (35 ft)
228297	15 m (50 ft)

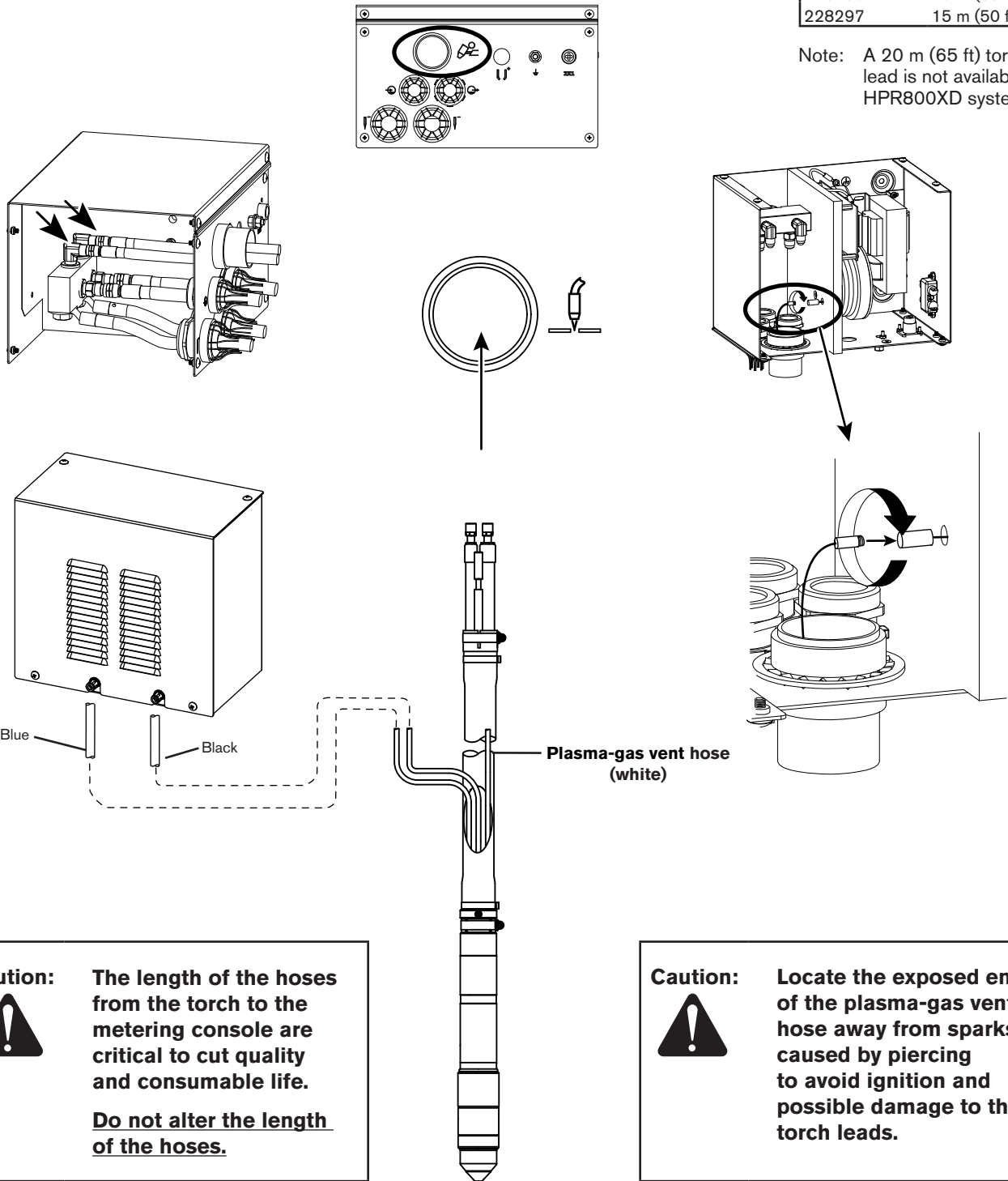
Note: A 20 m (65 ft) torch lead is not available for HPR800XD systems



Caution:  The length of the hoses from the torch to the metering console are critical to cut quality and consumable life. **Do not alter the length of the hoses.**

Caution:  Locate the exposed end of the plasma-gas vent hose away from sparks caused by piercing to avoid ignition and possible damage to the torch leads.

Torch lead junction box (Optional)

Note: See the *Parts list* for part numbers

Caution:



Total lead length from the ignition console to the torch must be less than or equal to:
20 m (65 feet) for HPR130XD / HPR260XD
15 m (50 feet) for HPR400XD / HPR800XD

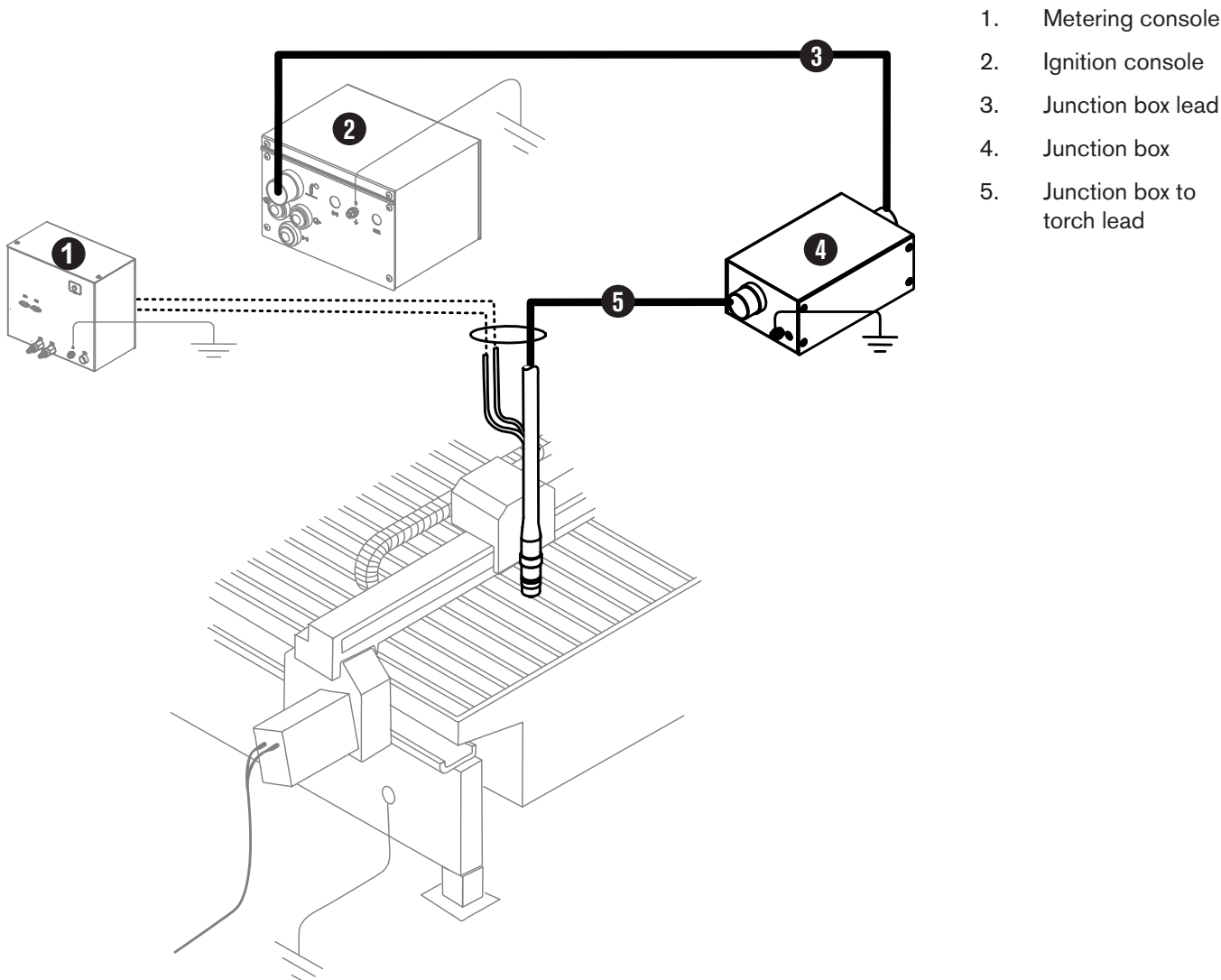

Install the junction box

1. Remove the cover from the junction box

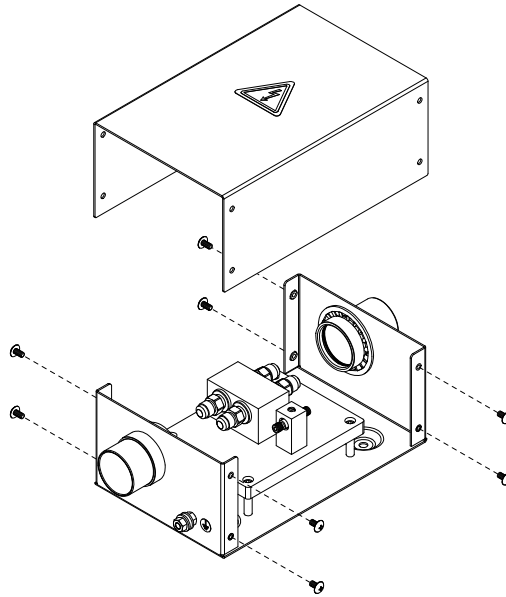

2. Mount the junction box near the cutting location. (See *Specification* – for Junction box mounting dimensions)

Note: Allow space to install and remove the cover of the box for servicing.

3. Ground the junction box to the bus bar on the cutting table or equivalent. See *Recommended grounding and shielding* in the *Installation* section in your system's instruction manual for more information.

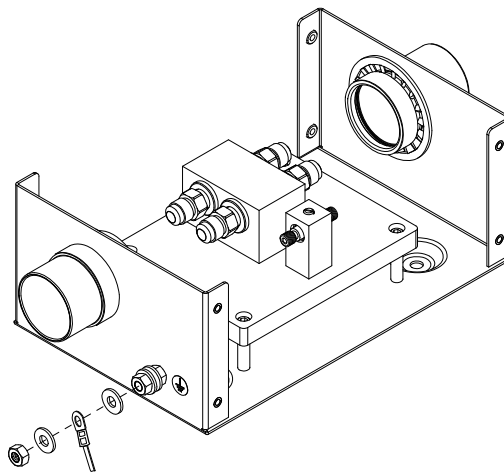

INSTALLATION

Connect the leads

Note: Do not overtighten the connections

Junction box to the ignition console

1. Connect one end of the junction box lead to the junction box.

Note: The lead can go in either end of the junction box.

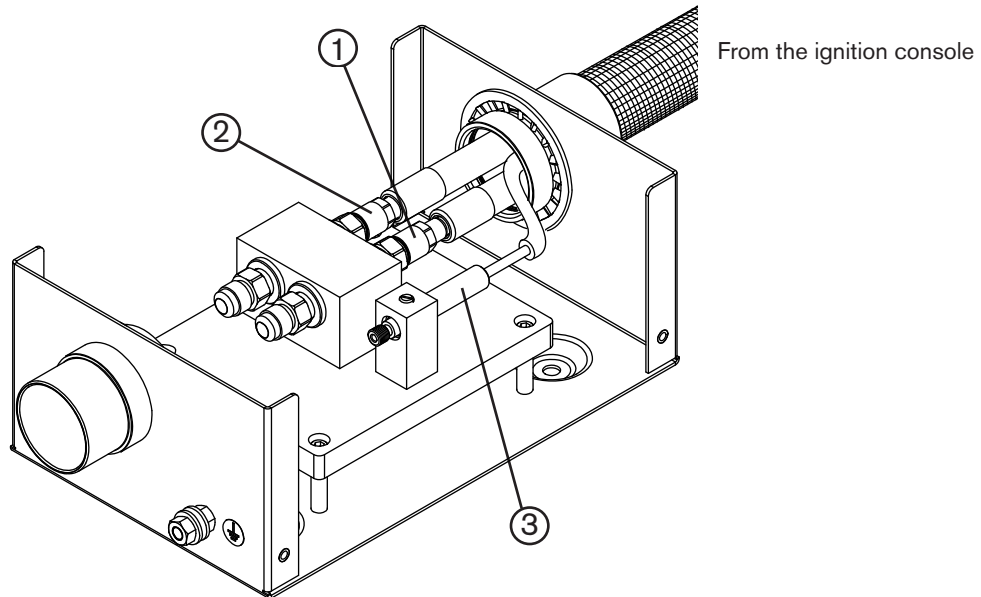

- 1 Coolant supply hose (green)
- 2 Coolant return hose (red)

- 3 Pilot arc lead (yellow)

2. Connect the other end of the junction box lead to the ignition console.

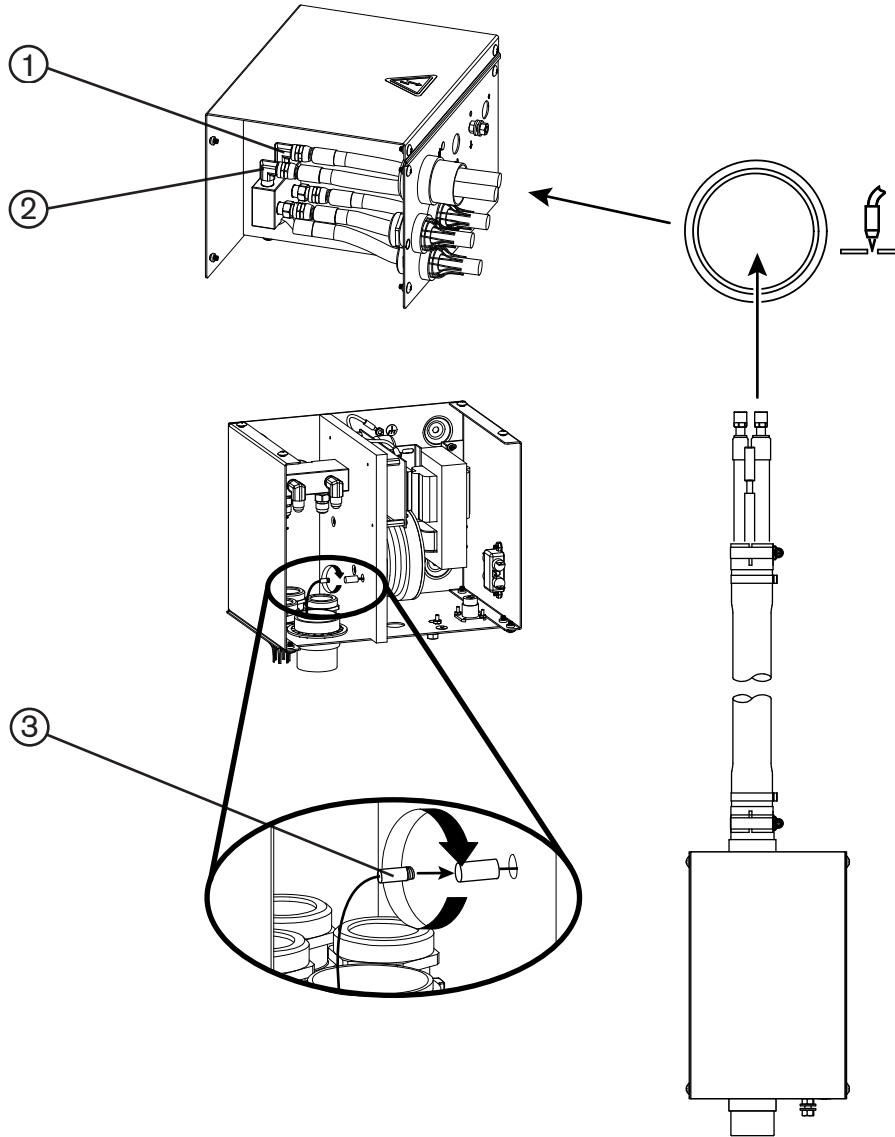

1 Coolant supply hose (green)

2 Coolant return hose (red)

3 Pilot arc lead (yellow)

INSTALLATION

Lead from the torch to the junction box

1. Connect the lead from the torch to the junction box.

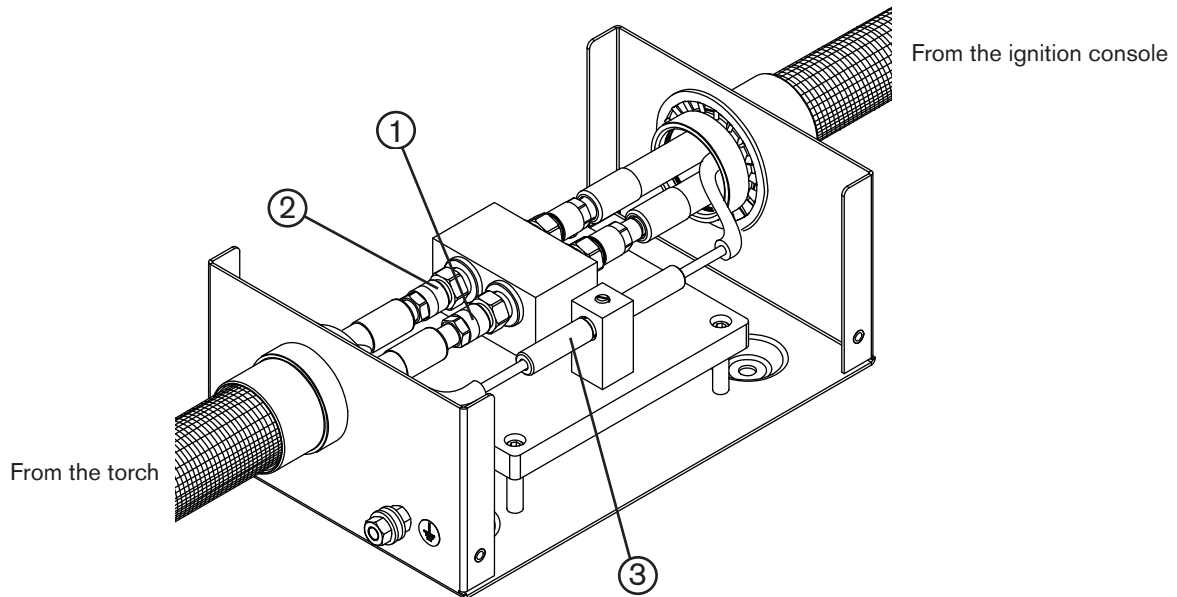

- 1 Coolant supply hose (green)
- 2 Coolant return hose (red)

- 3 Pilot arc lead (yellow)

2. Install the junction box cover.

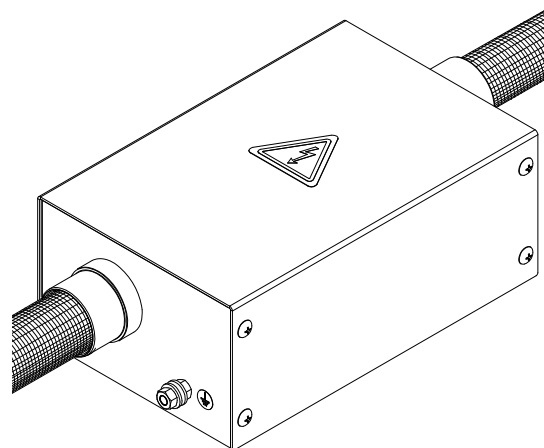

3. Connect the torch hoses to the metering console.

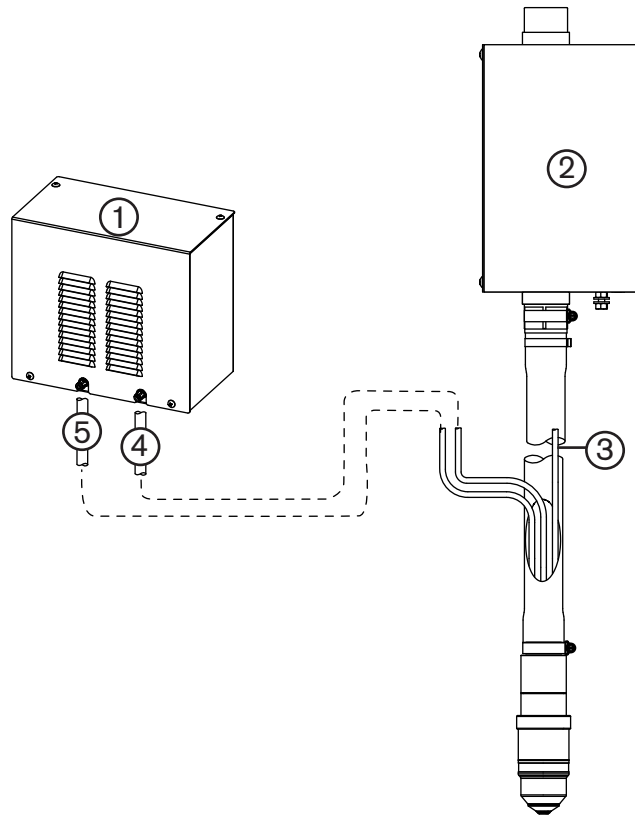

- 1 Metering console
- 2 Junction box
- 3 Plasma gas vent hose (white)
- 4 Plasma gas hose (black)
- 5 Shield hose (blue)

16 Work lead

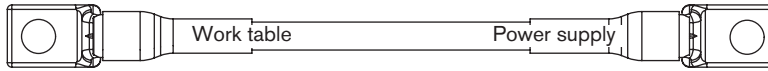

Part no.	Length	Part no.	Length
123418	3 m (10 ft)	123996	25 m (82 ft)
023382	4.5 m (15 ft)	123997	35 m (115 ft)
023078	7.5 m (25 ft)	023081	45 m (150 ft)
123994	10 m (35 ft)	023188	60 m (200 ft)
023079	15 m (50 ft)	023815	75 m (250 ft)
123995	20 m (65 ft)		

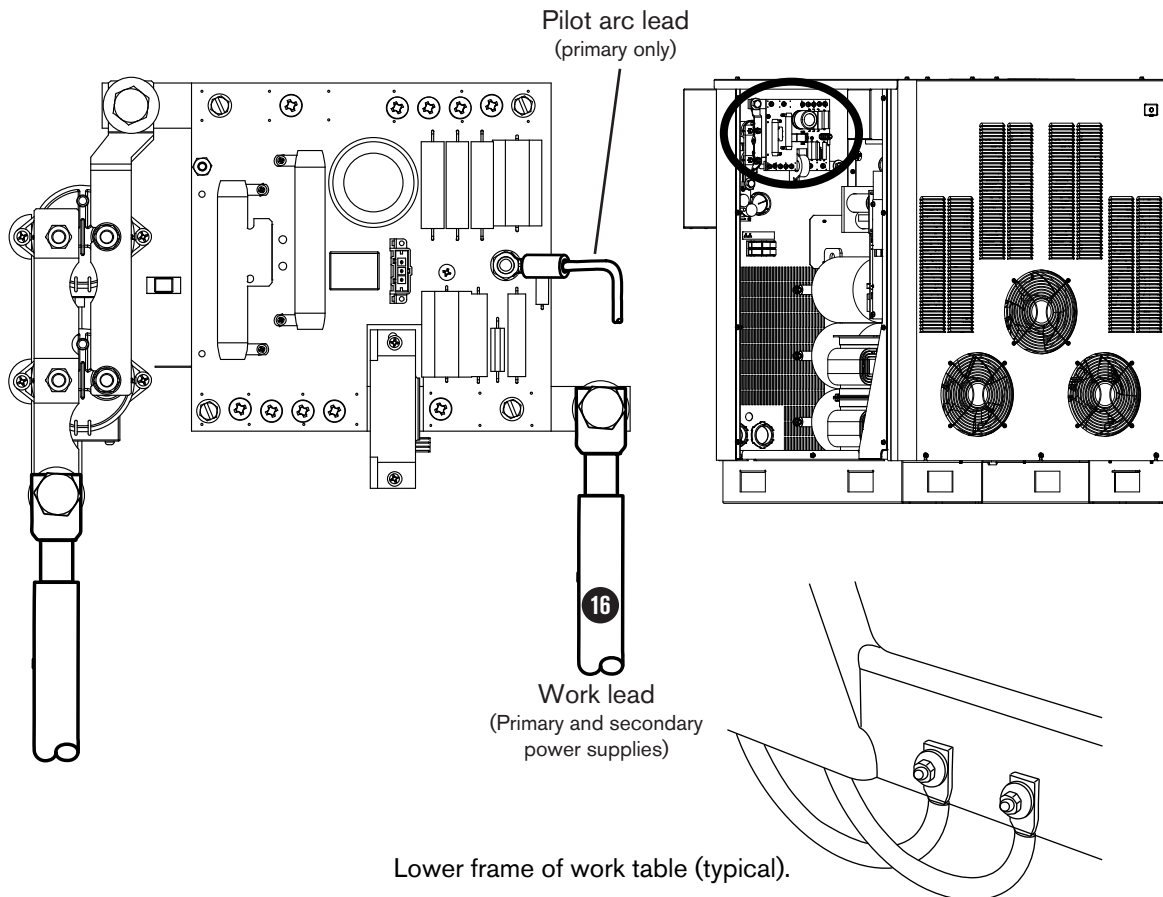
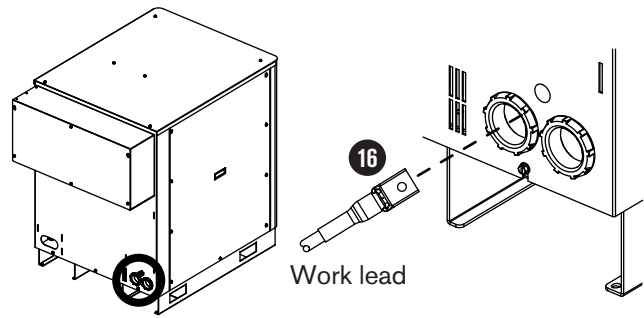
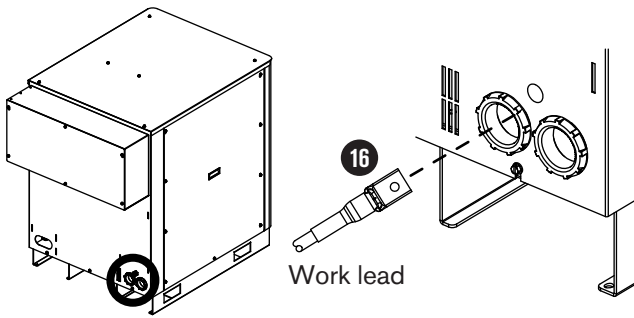

H Torch connections

Connect the torch to the torch lead assembly

1. Uncoil the first 2 meters (6.5 ft) of the leads on a flat surface.

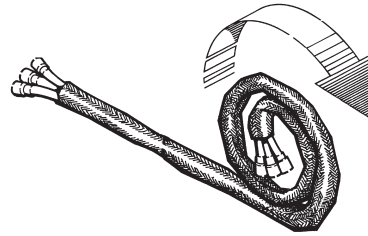

2. Hold the torch assembly in place with the spanner wrench (104269) and remove the mounting sleeve from the torch assembly.

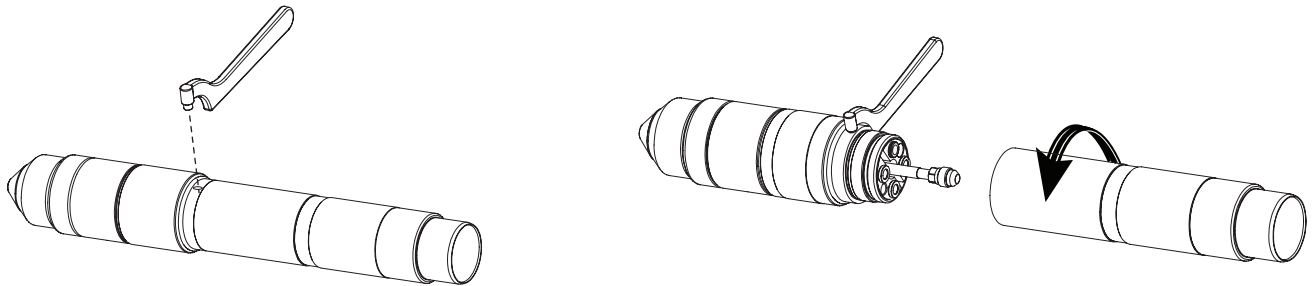

3. Push back the braided cover and slide the sleeve over the leads. Align the torch with the hoses in the lead assembly. The hoses must not be twisted. They are taped together to help prevent twisting.

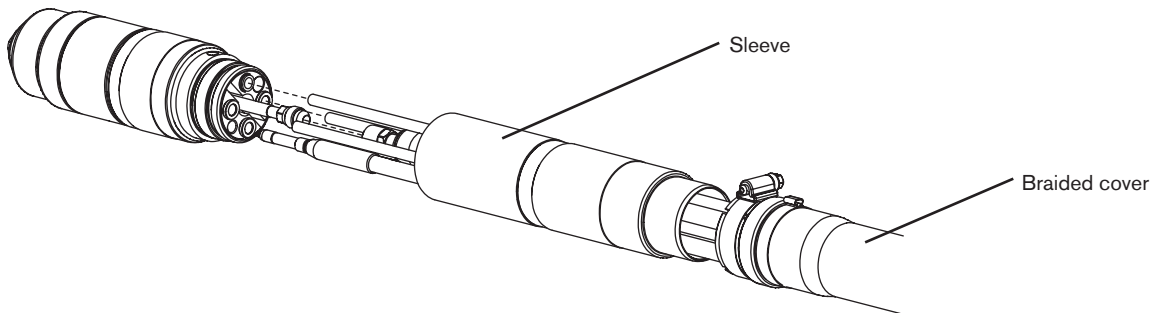

4. Connect the coolant return hose (red).

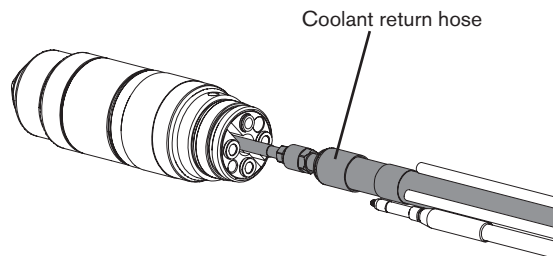
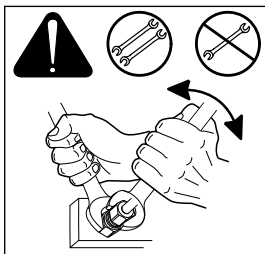

Caution: Never use PTFE tape on any joint preparation.



INSTALLATION

5. Connect the pilot arc lead (yellow). Insert the connector into the torch receptacle and turn it by hand until it is tight.

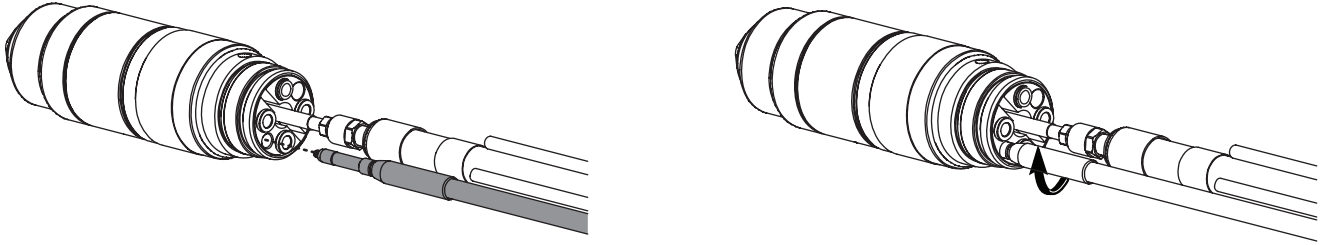

6. Connect the optional ohmic contact wire.

6a. Route the ohmic contact wire through the opening in the braided cover and the torch sleeve.

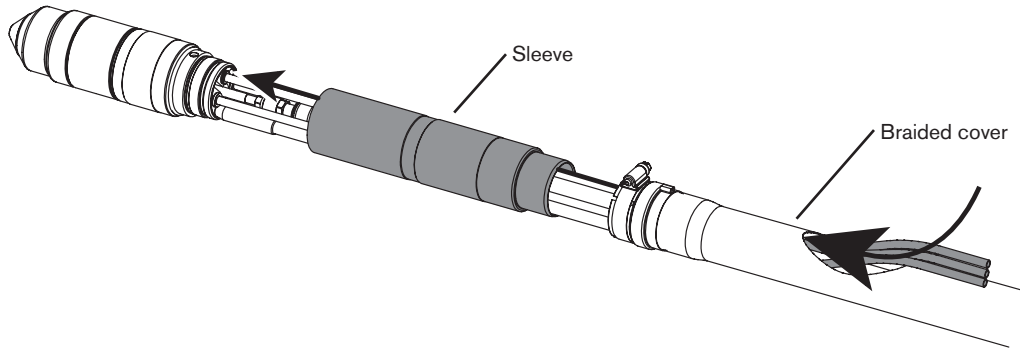

6b. Insert the connector into the torch receptacle and turn it by hand until it is tight.

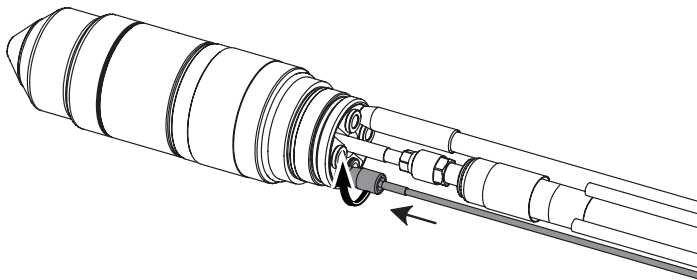

Ohmic contact wire part numbers (Not included with the HPR Torch Leads – order separately.)

Note: The Ohmic extension wire found in appendix C is for robotic applications only

Part no.	Length
123983	3 m (10 ft)
123984	6 m (20 ft)
123985	7.5 m (25 ft)
123986	9 m (30 ft)
123987	12 m (40 ft)
123988	15 m (50 ft)
123989	23 m (75 ft)
123990	30 m (100 ft)
123991	45 m (150 ft)

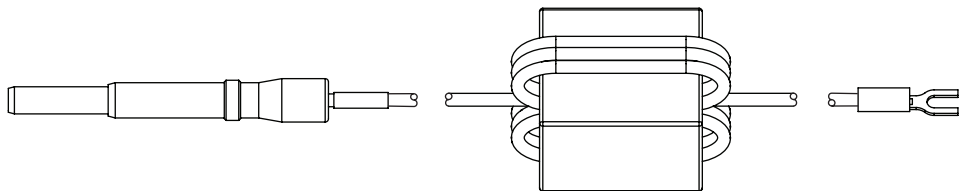

7. Connect the plasma-gas vent hose (white).

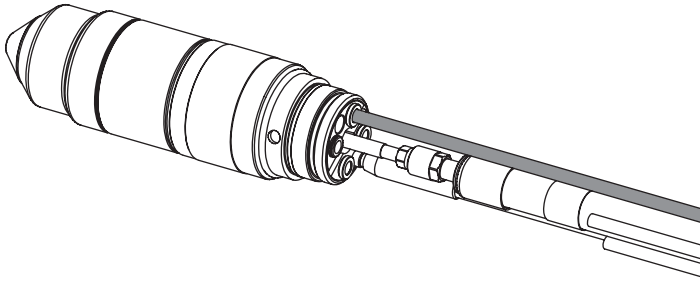

8. Connect the coolant supply hose (green).

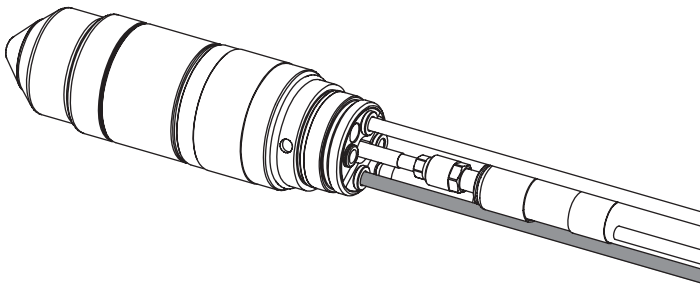

9. Connect the plasma gas hose (black).

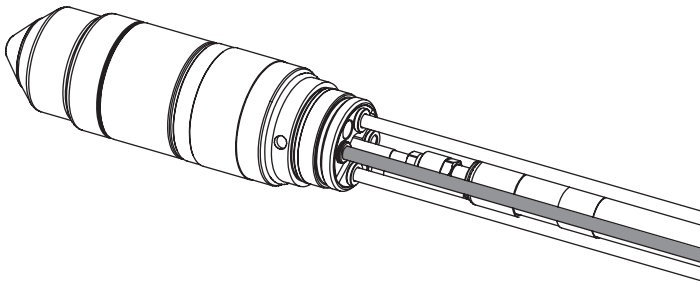

10. Connect the shield gas hose (blue).

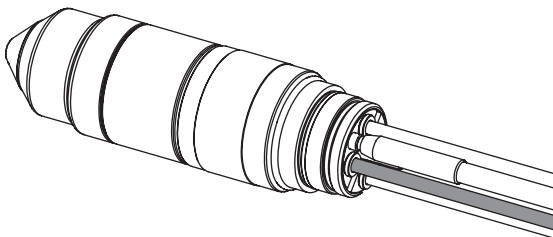

Note: The connectors in steps 7–10 are push-to-connect fittings.

To make a connection, push the hose fitting into the appropriate connector until it stops, 13 mm (0.5 in.).

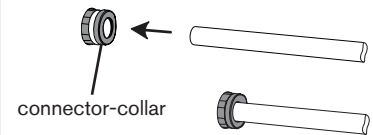

To disconnect a fitting, push the connector-collar toward the torch, and pull the hose away from the torch.



INSTALLATION

11. Slide the torch sleeve over the connections and screw it onto the torch assembly.

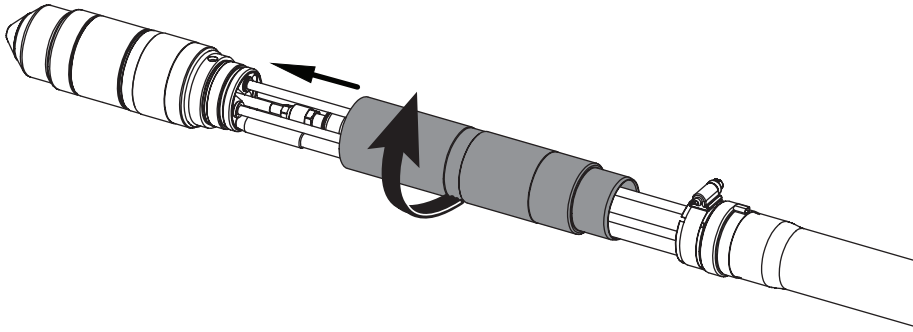

12. Slide the braided cover up to the torch sleeve. Make sure that the plasma, shield and vent hoses are routed through the hole in the braided cover. Loosen the hose clamp on the braided cover, slide the braided cover and clamp over the sleeve and tighten the clamp.

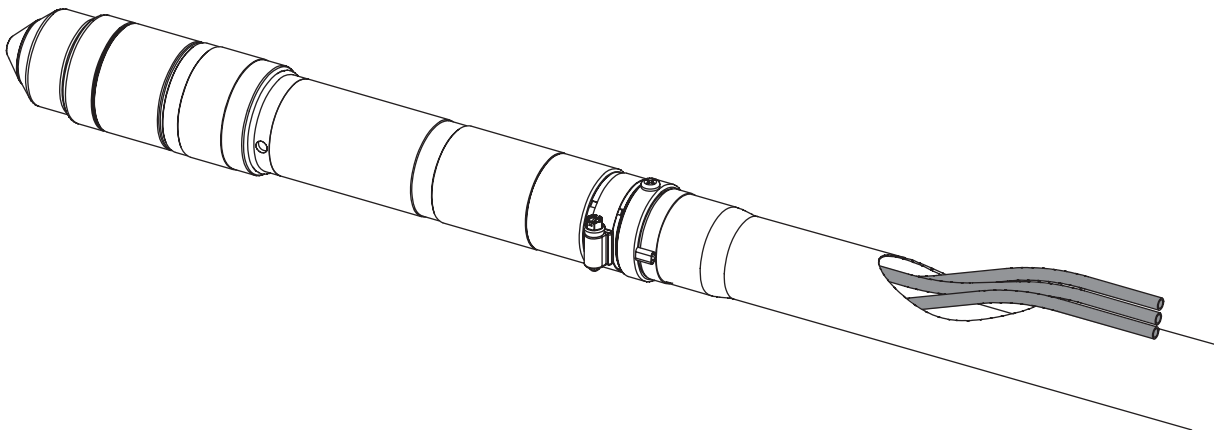

Connect the torch to the quick-disconnect

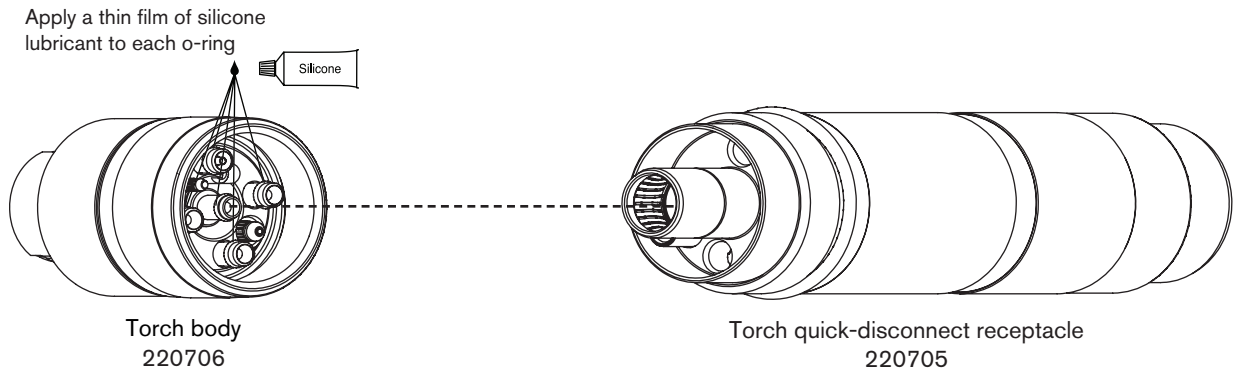

Installation note

Align the torch body to the torch leads and secure by screwing completely together. Be certain that there is no space between the torch body and the o-ring on the torch leads. See also *Torch connections* earlier in this section for torch lead connections to ignition console.

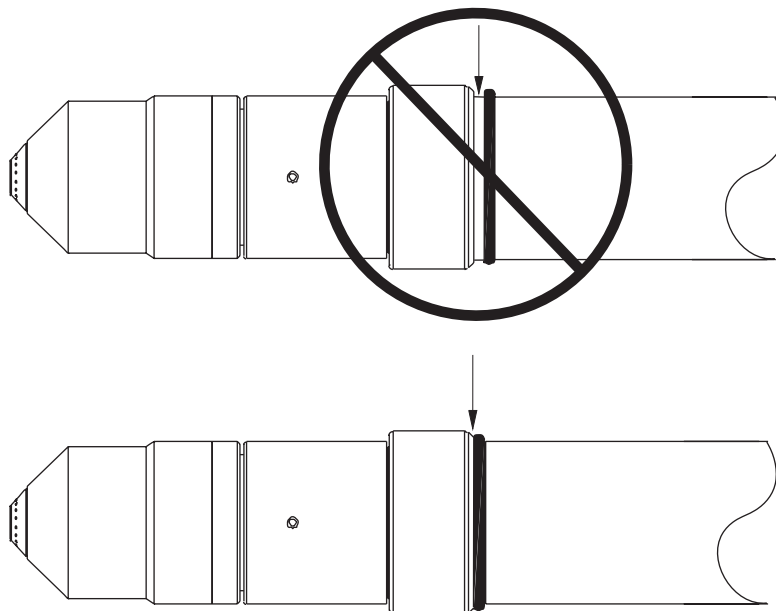

Torch mounting and alignment

Mounting the torch

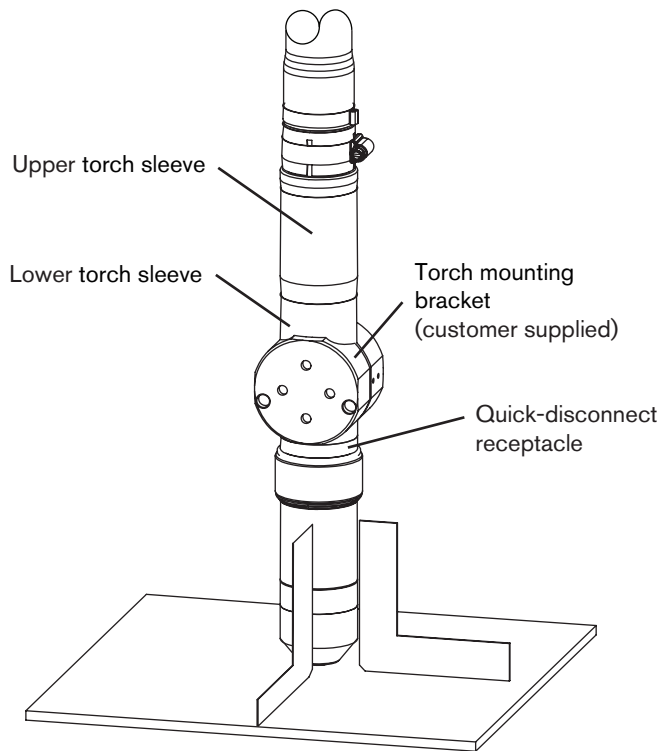

Installation

1. Install the torch (with torch leads attached) in the torch mounting bracket.
2. Position the torch below the mounting bracket, so that the bracket is around the lower portion of the torch sleeve but not touching the torch quick-disconnect.
3. Tighten the securing screws.

Note: The bracket should be as low on the torch sleeve as possible to minimize vibration at the tip of the torch.

Torch alignment

To align the torch at right angles to the workpiece, use a square. See figure above.

Torch lifter requirement

The system requires a high-quality, motorized torch lifter with sufficient travel to cover all cutting thickness requirements. The lifter must provide 203 mm (8 in) of vertical travel. The unit should have the capability of maintaining a constant speed of up to 5080 mm/min (200 ipm) with positive braking. A unit which drifts through the stop point is not acceptable.

HyperNet

An HPRXD system can be connected to the ArcGlide® torch height control, and an EDGE® Pro or MicroEDGE® Pro CNC using an ethernet hub and cable. The HyperNet PCB provides communication between components, including the divided arc voltage needed for the torch height control. See the ArcGlide instruction manual (806450), the EDGE Pro instruction manual (806360) or the MicroEDGE Pro CNC instruction manual (807290) for more information.

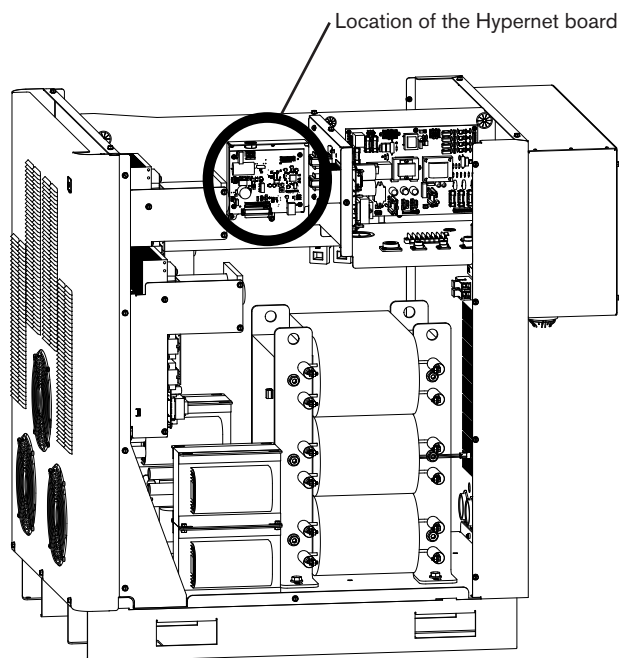

INSTALLATION

Power requirements (for each power supply)

General

All switches, slow-blow fuses and power cables are customer-supplied and must be chosen as outlined by applicable national and local electrical codes. Installation must be performed by a licensed electrician. Use a separate, primary, line disconnect switch for the power supply. Recommendations on fuse and circuit breaker sizing are listed below, however actual sizes required will vary based on individual site electrical line conditions (including but not limited to: source impedance, line impedance, and line voltage fluctuation), product inrush characteristics, and regulatory requirements.

The main feed protection device (circuit breaker or fuse) must be sized to handle all branch-feed loads for both inrush and steady-state current. The power supply must be wired into one of the branch-feed circuits. The power supply has a steady-state current listed in the table below.

Use a motor-start circuit breaker or equivalent if time delay high inrush fuses are not permitted by local and national codes. Time delay fuses and circuit breakers must be capable of withstanding inrush current that is up to 30 times the rated input current (FLA) for 0.01 seconds and up to 12 times the rated input current (FLA) for 0.1 seconds.

Note: The table below is for reference only. All local and national electrical code must be followed.

Input voltage	Phase	Rated input current @ 80 kW output	Recommended high inrush, time delay, fuse size	Recommended cable size for 15 m (50 ft) maximum length
				Rated for 90° C (194° F)
200/208 VAC	3	262/252 amps	325 amps	235 mm ² (350 MCM)
220 VAC	3	238 amps	300 amps	201.1 mm ² (300 MCM)
240 VAC	3	219 amps	275 amps	167.5 mm ² (250 MCM)
380 VAC	3	138 amps	175 amps	67.5 mm ² (2/0 AWG)
400 VAC	3	131 amps	175 amps	67.5 mm ² (2/0 AWG)
440 VAC	3	120 amps	150 amps	53.5 mm ² (1 AWG)
480 VAC	3	110 amps	150 amps	53.5 mm ² (1 AWG)
600 VAC	3	88 amps	110 amps	26.7 mm ² (3 AWG)

Note: Cable AWG recommendations taken from table 310-16 of the National Electric Code handbook (USA).

Line disconnect switch

The line disconnect switch serves as the supply-voltage disconnecting (isolating) device. Install this switch near the power supply for easy access by the operator.

Installation must be performed by a licensed electrician and according to applicable national and local codes.

The switch should:

- Isolate the electrical equipment and disconnect all live conductors from the supply voltage when in the “OFF” position
- Have one “OFF” and one “ON” position clearly marked with “O” (OFF) and “I” (ON)
- Have an external operating handle capable of being locked in the “OFF” position
- Contain a power-operated mechanism that serves as an emergency stop
- Have slow-blow fuses installed for the proper breaking capacity (see table above).

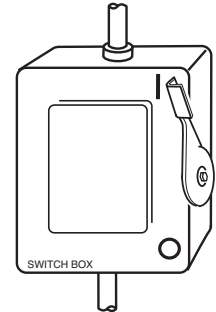

17 Main power cable (power supplies)



Wire sizes vary based on the distance of the receptacle from the main box. The wire sizes listed in the table on the previous page were taken from the National Electric Code 1990 handbook, table 310.16 (USA). Use a 4-conductor Type SO input power cable with a conductor temperature rating of 90° C (194° F). Installation must be performed by a licensed electrician.

18 Main power cable (chiller)

See the Chiller manufacturer manual for more information.

INSTALLATION

Connect the power

		<p style="text-align: center;">DANGER ELECTRIC SHOCK CAN KILL</p>
<p>The line disconnect switch must be in the OFF position before making the power cable connections. In the U.S., use a “lock-out/tag-out” procedure until installation is complete. In other countries, follow appropriate national and local safety procedures.</p>		

1. Insert the power cable through the strain relief at the rear of the power supply.
2. Connect the ground lead (PE) to the GROUND terminal () of TB1 as shown below.
3. Connect the power leads to the terminals of TB1 as shown below.
4. Verify that the line disconnect switch is in the OFF position and remains in the OFF position for the remainder of the installation of the system.
5. Connect the power cord leads to the line disconnect switch following national and local electrical codes.

North American wire colors

U = Black

V = White

W = Red

(PE) Earth ground = Green/Yellow

European wire colors

U = Black

V = Blue

W = Brown

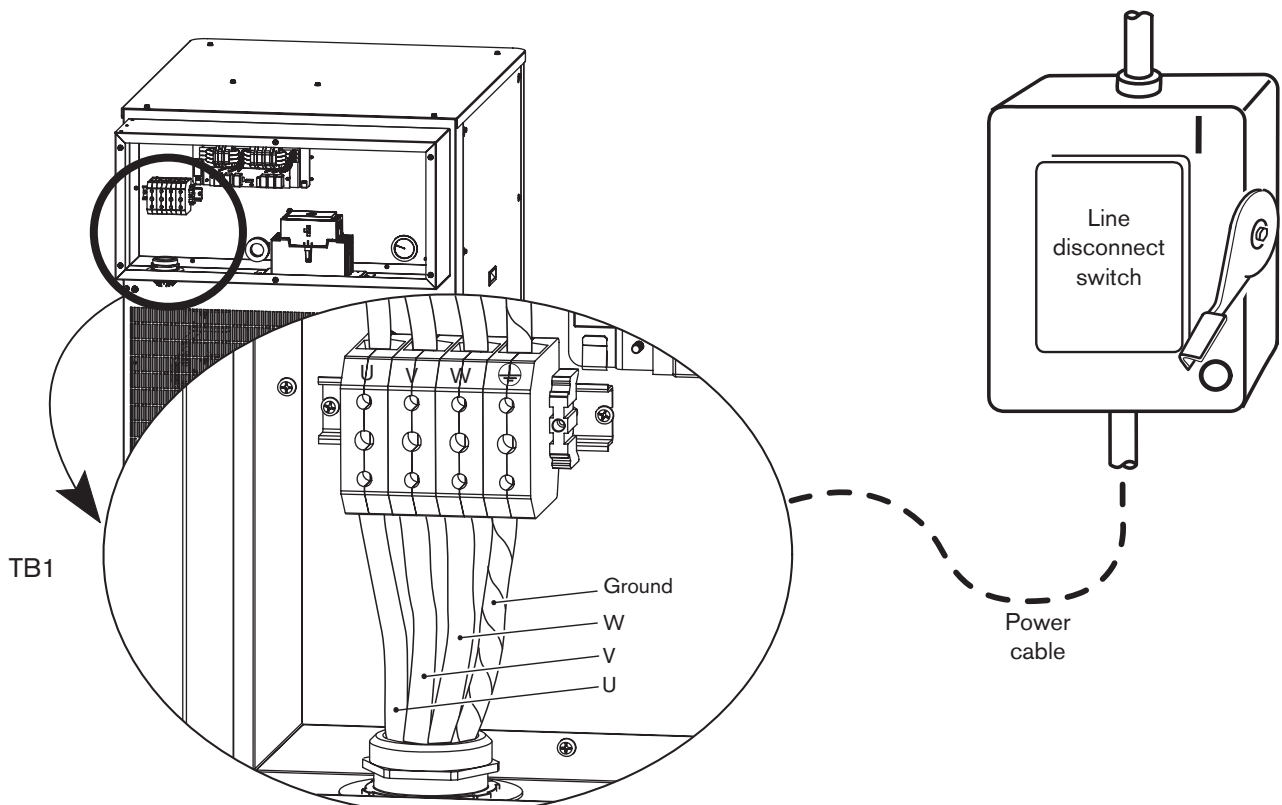

(PE) Earth ground = Green/Yellow



Torch coolant requirements

The system is shipped without any coolant in the tank. Before filling the coolant system, determine what coolant mix is correct for your operating conditions.

Observe the warning and cautions below. Refer to the *Material Safety Data Sheets* appendix for data on safety, handling, and storage of propylene glycol and benzotriazole.

		<p>DANGER COOLANT CAN BE IRRITATING TO SKIN AND EYES AND HARMFUL OR FATAL IF SWALLOWED</p>
<p>Propylene glycol and benzotriazole are irritating to skin and eyes, and harmful or fatal if swallowed. Upon contact, flush skin or eyes with water. If swallowed, seek immediate medical attention.</p>		

	<p>CAUTION</p>
<p>Never use automotive anti-freeze in place of propylene glycol. Antifreeze contains corrosion inhibitors that will damage the torch coolant system.</p> <p>Always use purified water in the coolant mixture in order to prevent damage to the pump and corrosion in the torch coolant system.</p>	

Definitions

Ambient temperature – The temperature of the room in which the chiller is being used.

Chiller operating temperature – The temperature of the coolant inside the chiller.

Premixed coolant for standard operating temperatures

Use Hypertherm premixed coolant (028872) when operating in an ambient temperature range of -12° C to 40° C (10° F to 104° F), and when operating at chiller process temperatures of 4° C to 35° C (59° F to 95° F). Refer to the custom coolant mix recommendations, if temperatures during operation are ever outside of this range.

Hypertherm premixed coolant consists of 69.8% water, 30% propylene glycol, and 0.2% benzotriazole.

INSTALLATION

Custom Coolant mix for cold operating temperatures

- Ambient temperature below -12° C / 10° F
- Chiller process temperature below 4° C / 39° F



CAUTION

For operating temperatures colder than the temperature stated above, the percentage of propylene glycol must be increased. Failure to do so could result in a cracked torch head, hoses, or other damage to the torch coolant system due to freezing.

Use the chart below to determine what percentage of propylene glycol to use in the mixture.

Mix 100% glycol (028873) with the premixed Hypertherm coolant (028872) to increase the percentage of glycol. The 100% glycol solution can also be mixed with purified water (see the chart below for water purity requirements) to achieve the required protection from freezing.

Note: The maximum percentage of glycol should never exceed 50%. Increasing the percentage of glycol reduces the capacity of the cooling system.

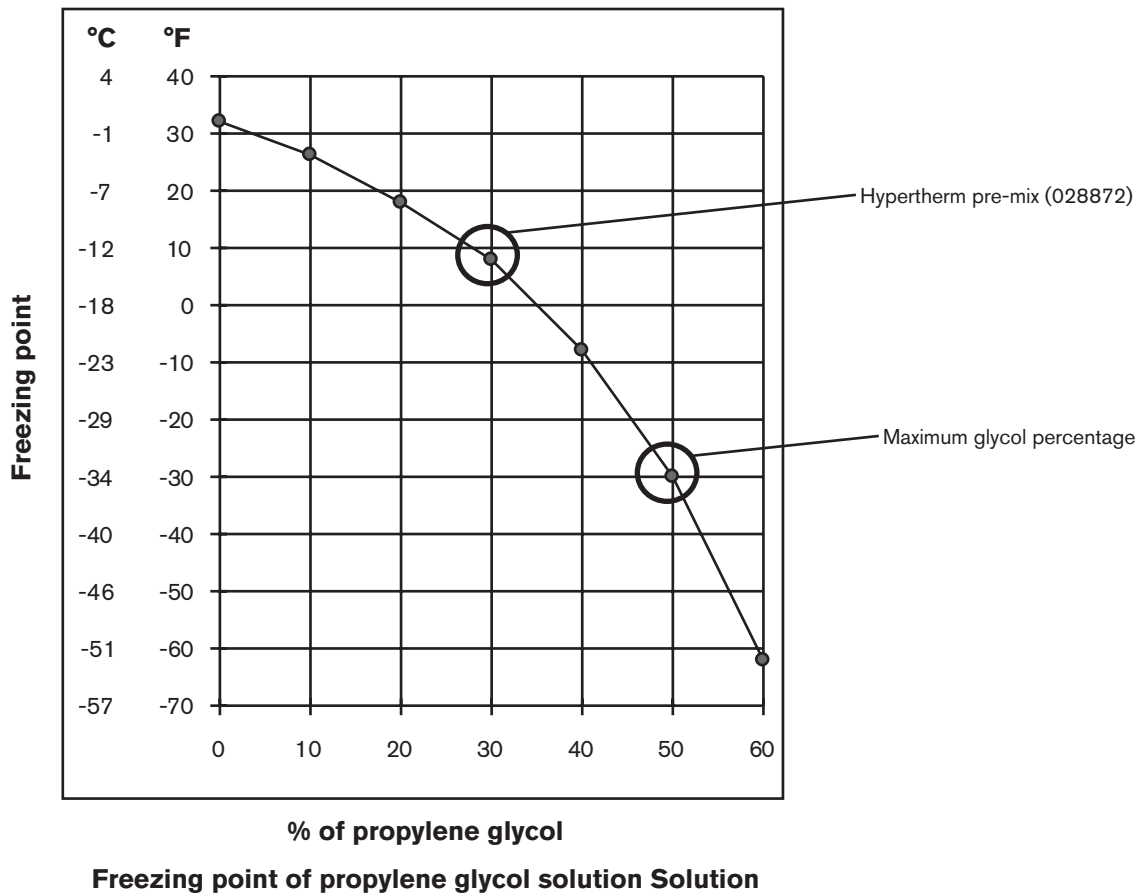

Custom Coolant mix for hot operating temperatures (above 38° C / 100° F)

Treated water (with no propylene glycol) can only be used as coolant when ambient temperatures are **never** below 0° C (32° F), and chiller process temperatures are never below 14° C (57° F). For operations in very warm temperatures, treated water will provide the best cooling properties.

	<p>CAUTION</p>
<p>When using treated water the chiller default settings must be changed to prevent damage to the chiller. See the chiller manufacturer manual for more details.</p>	

Treated water refers to a mixture of purified water, that meets the specifications below, and 1 part benzotriazole (BZT) to 300 parts of water. BZT (128020) acts as a corrosion inhibitor for the copper based coolant system contained in the plasma system.

Water purity requirements

It is critical to maintain a low level of calcium carbonate in the coolant to avoid reduced performance of the torch or cooling system.

Always use water that meets the minimum and maximum specifications in the table below when using a custom coolant mix.

Water that does not meet the minimum purity specifications below can cause excessive deposits on the nozzle that will alter the water flow and produce an unstable arc.

Water that does not meet the maximum purity specifications below can also cause problems. Deionized water that is too pure will cause leaching problems with the coolant system plumbing.

Use water purified by any method (deionization, reverse osmosis, sand filters, water softeners, etc.) as long as the water purity meets the specifications in the table below. Contact a water specialist for advice in choosing a water filtration system.

Water purity	Water purity measurement method			
	Conductivity μS/cm at 25° C (77° F)	Resistivity mΩ-cm at 25° C (77° F)	Dissolved solids (ppm of NaCl)	Grains per gallon (gpg of CaCO ₂)
Pure water (for reference only)	0.055	18.3	0	0
Maximum purity	0.5	2	0.206	0.010
Minimum purity	18	0.054	8.5	0.43
Maximum potable water (for reference only)	1000	0.001	495	25

Fill the chiller with coolant

See the chiller manufacturer manual for details

Caution: The first time the chiller is operated it should be run according to the chiller manufacturer manual.



Caution: Do not turn ON the power to the controller until the chiller reservoir has been filled. When the power to the controller is turned ON the pump automatically begins pumping. If the reservoir has not been filled, the pump could be damaged.



Caution: Using the wrong coolant can cause damage to the system. Refer to *torch coolant requirements* in this section for more information.



Do not over fill the coolant tank.

Gas requirements

The customer must furnish all gases and gas-supply regulators for the system. Use a high-quality, 2-stage pressure regulator located within 3 m (10 ft) of the selection console. See *gas regulators* in this section for recommendations. See the *Specifications* section for gas and flow specifications. See *Supply gas hoses* at the end of this section for recommendations.

Caution: **Gas supply pressures not within the specifications in Section 2 can cause poor cut quality, poor consumable life and operational problems.**

 **If the purity level of the gas is too low or if there are leaks in the supply hoses or connections,**

- **Cut speeds can decrease**
- **Cut quality can deteriorate**
- **Cutting thickness capability can decrease**
- **Parts life can shorten**

Setting the supply regulators

1. Turn OFF the power to the system. Set all gas regulator pressures to 8 bar (115 psi).
2. Turn ON the power to the system using the remote ON/OFF switch or the CNC.
3. Set to Test Preflow.
4. While gas is flowing adjust the supply regulator for the shield gas to 8 bar (115 psi).



5. Turn OFF Test Preflow.
6. Set system to Test Cutflow.
7. While gas is flowing adjust the supply regulator for the plasma gas to 8 bar (115 psi).

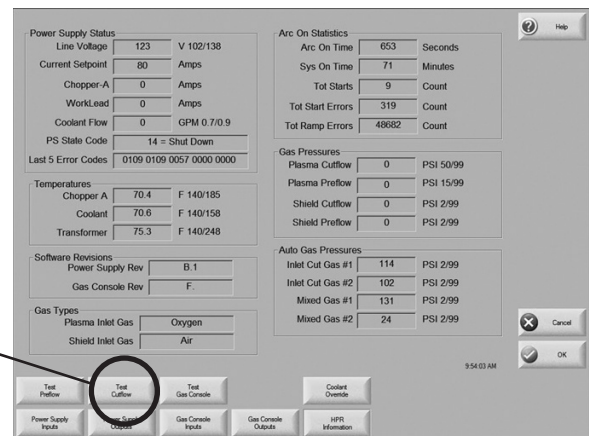

8. Turn OFF Test Cutflow.

INSTALLATION

Gas regulators

Low-quality gas regulators do not provide consistent supply pressures and can result in poor cut quality and system operation problems. Use a high-quality, 1-stage, gas regulator to maintain consistent gas supply pressure, if using liquid cryogenic or bulk storage. Use a high-quality, 2-stage, gas regulator to maintain consistent gas supply pressure from high pressure gas cylinders.

The high-quality gas regulators listed below are available from Hypertherm and meet U.S. Compressed Gas Association (CGA) specifications. In other countries, select gas regulators that conform to national and local codes.

2-stage regulator



Single stage regulator



Part Number	Description	Qty.
128544	Kit: Oxygen, 2-stage *	1
128545	Kit: Inert Gas, 2-stage	1
128546	Kit: Hydrogen (H5, H35 and methane) 2-stage	1
128547	Kit: Air, 2-stage	1
128548	Kit: 1-stage (for use with cryogenic liquid nitrogen or oxygen)	1
022037	Oxygen, 2-stage	1
022038	Inert gas, 2-stage	1
022039	Hydrogen/methane, 2-stage	3
022040	Air, 2-stage	1
022041	Line regulator, 1-stage	1

* Kits include appropriate fittings

Supply gas plumbing

Rigid copper plumbing or suitable flexible hose may be used for all gas supplies. Do not use steel or aluminum pipe. After installation, pressurize the entire system and check for leaks.

Recommended hose diameters are 9.5 mm (3/8 in) for lengths < 23 m (75 ft) and 12.5 mm (1/2 in) for lengths > 23 m (75 ft).

For flexible-hose systems, use a hose designed for inert gas to carry air, nitrogen or argon-hydrogen. See the last page of this section for hose part numbers.

Caution: Never use PTFE tape on any joint preparation.



Caution: When connecting the selection console to the supply gases, make sure that all hoses, hose connections and fittings are acceptable for use with oxygen and argon-hydrogen. Installation must be made in accordance with national and local codes.



Note: When cutting with oxygen as the plasma gas, air must also be connected to the selection console to achieve the proper mixtures in the preflow and cutflow modes.



WARNING
CUTTING WITH OXYGEN CAN CAUSE FIRE OR EXPLOSION

Cutting with oxygen as the plasma gas can cause a potential fire hazard due to the oxygen-enriched atmosphere that it creates. As a precaution, Hypertherm recommends that an exhaust ventilation system be installed when cutting with oxygen.

Flashback arrestors are required (unless not available for specific gases or required pressures) to prevent fire from propagating back to supply gas.

INSTALLATION

Connect the supply gases

Connect the supply gases to the selection console. Torch leads must be purged between gas changes.

Caution: Synthetic lubricants containing esters that are used in some air compressors will damage polycarbonates used in the air regulator bowl.



Fitting	Size
N ₂ / Ar	5/8 – 18, RH, internal (inert gas) "B"
Air	9/16 – 18, JIC, no. 6
H35 / F5 / H5	9/16 – 18, LH, (fuel gas) "B"
O ₂	9/16 – 18, RH, (oxygen) "B"

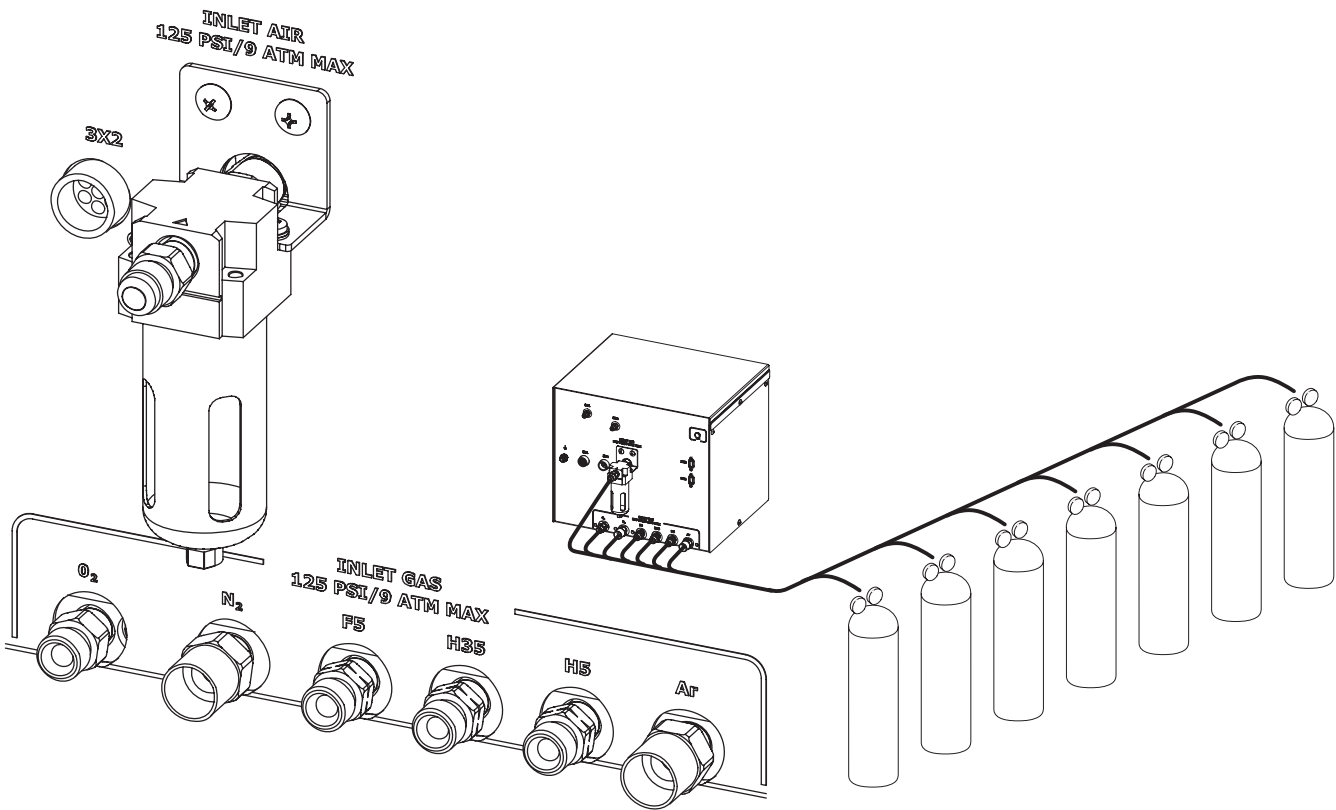

Caution: Replacing the fittings on the selection console may cause the internal valves to malfunction, because particulates can migrate into the valves.



Supply gas hoses

19 Oxygen hose

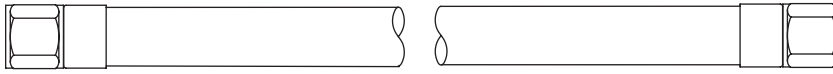

Caution: Never use PTFE tape on any joint preparation.

Part no.	Length	Part no.	Length
024607	3 m (10 ft)	024738	25 m (82 ft)
024204	4.5 m (15 ft)	024450	35 m (115 ft)
024205	7.5 m (25 ft)	024159	45 m (150 ft)
024760	10 m (35 ft)	024333	60 m (200 ft)
024155	15 m (50 ft)	024762	75 m (250 ft)
024761	20 m (65 ft)		

20 Nitrogen or argon hose



Part no.	Length	Part no.	Length
024210	3 m (10 ft)	024739	25 m (82 ft)
024203	4.5 m (15 ft)	024451	35 m (115 ft)
024134	7.5 m (25 ft)	024120	45 m (150 ft)
024211	10 m (35 ft)	024124	60 m (200 ft)
024112	15 m (50 ft)	024764	75 m (250 ft)
024763	20 m (65 ft)		

21 Air hose

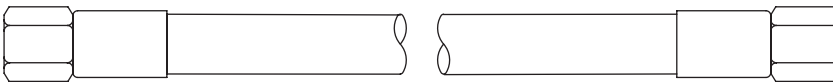

Part no.	Length	Part no.	Length
024671	3 m (10 ft)	024740	25 m (82 ft)
024658	4.5 m (15 ft)	024744	35 m (115 ft)
024659	7.5 m (25 ft)	024678	45 m (150 ft)
024765	10 m (35 ft)	024680	60 m (200 ft)
024660	15 m (50 ft)	024767	75 m (250 ft)
024766	20 m (65 ft)		

22 Argon-hydrogen (H35) or nitrogen-hydrogen (F5)

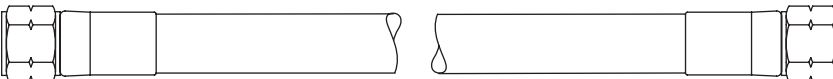

Part no.	Length	Part no.	Length
024768	3 m (10 ft)	024741	25 m (82 ft)
024655	4.5 m (15 ft)	024742	35 m (115 ft)
024384	7.5 m (25 ft)	024743	45 m (150 ft)
024769	10 m (35 ft)	024771	60 m (200 ft)
024656	15 m (50 ft)	024772	75 m (250 ft)
024770	20 m (65 ft)		

This page is blank intentionally

Section 4

OPERATION

In this section:

Daily start-up.....	4-3
Check torch	4-3
Power indicators	4-4
General	4-4
Power supply.....	4-4
Selection console.....	4-4
Chiller interface console	4-4
Metering console.....	4-4
CNC controller requirements.....	4-5
CNC screen examples.....	4-6
Main (control) screen.....	4-6
Diagnostic screen	4-7
Test screen	4-8
Cut chart screen.....	4-9
Consumable selection	4-10
Standard cutting (0°).....	4-10
Bevel cutting (0° to 45°).....	4-10
PowerPierce technology.....	4-10
Marking	4-10
Consumables for mirror-image cutting.....	4-10
SilverPlus electrodes	4-10
Mild steel	4-11
Stainless steel	4-12
Aluminum.....	4-13
Mild steel bevel cutting	4-14
Mild steel, thick piercing, bevel cutting	4-14
Stainless steel bevel cutting	4-15
Install and Inspect consumables	4-16
Torch maintenance	4-20
Routine maintenance	4-20
Quick-disconnect maintenance	4-20
Maintenance kit.....	4-20

OPERATION

Torch connections	4-21
Replace torch water tube.....	4-21
Common cutting faults	4-22
How to optimize cut quality	4-23
Tips for table and torch.....	4-23
Plasma set-up tips.....	4-23
Maximize the life of consumable parts.....	4-23
Additional factors of cut quality.....	4-24
Additional improvements	4-26
Cut charts.....	4-27
Thin stainless steel with HDi technology.....	4-27
Overview.....	4-27
Thick stainless steel piercing technique.....	4-28
Overview.....	4-28
Fine Feature cutting.....	4-30
Overview.....	4-30
Recommendations	4-30
Bevel cutting	4-31
Consumables	4-31
Bevel compensation tables.....	4-31
Bevel cutting definitions	4-32
Cutting thick material	4-33
Underwater cut charts	4-34
Overview.....	4-34
Estimated kerf-width compensation	4-36

Daily start-up

Prior to start-up, ensure that your cutting environment and that your clothing meet the safety requirements outlined in the *Safety* section of this manual.

Check torch

		<p>DANGER ELECTRIC SHOCK CAN KILL</p>
<p>Before operating this system, you must read the <i>Safety</i> section thoroughly. Turn OFF the power supply's main disconnect switch before proceeding with the following steps.</p>		

1. Turn main disconnect switch to the power supply OFF.
2. Remove the consumables from the torch and check for worn or damaged parts. **Always place the consumables on a clean, dry, oil-free surface after removing. Dirty consumables can cause the torch to malfunction.**
 - Refer to *Install and inspect consumables* later in this section for details and for parts inspection tables.
 - Refer to the *Cut charts* to choose the correct consumables for your cutting needs.
3. Replace consumable parts. Refer to *Install and inspect consumables* later in this section for details.
4. Ensure that the torch is perpendicular to the workpiece.

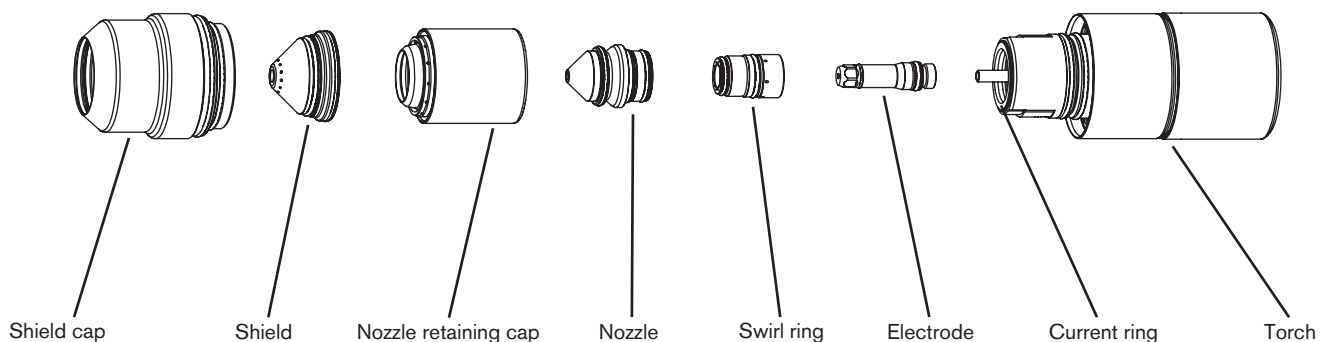

Power indicators

General

When the HPR receives a "Remote On" signal from the CNC, the HPR800XD, selection console, and the metering console controls are powered on and initialized. The green indicator lights will also come on.

Power supply

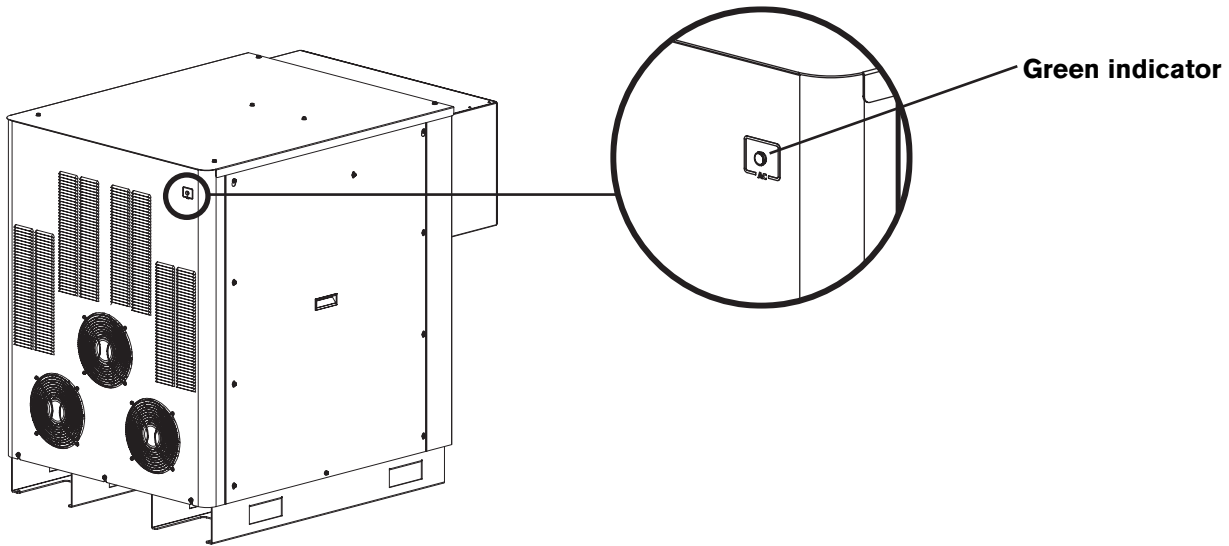

Selection console

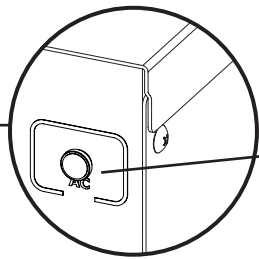
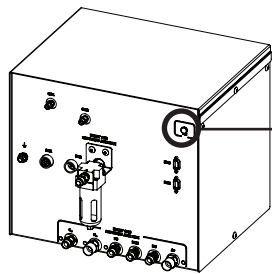

Metering console

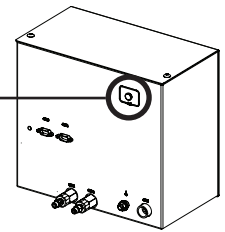
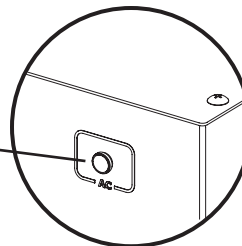

Chiller interface console

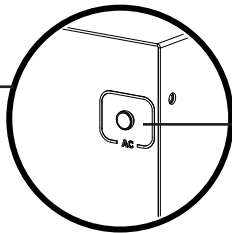
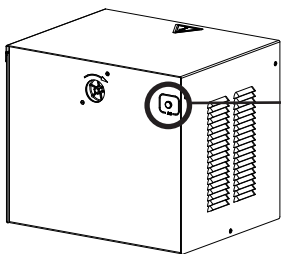

Green
indicator

CNC controller requirements

Note: See appendix B, *CNC interface protocol*, for more detailed information.

Base required elements

The following elements should be able to be displayed and adjusted on the CNC for setup and basic system information. The plasma system needs this group for basic setup and operation capability.

1. Remote ON/OFF
2. Ability to display and adjust the basic plasma process set-points (command ID no. 95)
 - a. Current set point
 - b. Plasma preflow
 - c. Plasma cutflow
 - d. Shield preflow
 - e. Shield cutflow
 - f. Plasma gas type
 - g. Shield gas type
 - h. Gas mixing set-points
3. Display basic system information
 - a. System error code
 - b. Gas and PS firmware version
4. Manual pump control

Required real time elements

Note: These elements are not available for the secondary power supply.

The following elements should be able to be displayed in real time while cutting. This is necessary for troubleshooting and diagnostic purposes.

5. Display line voltage
6. Display chopper current
7. Display work lead current
8. Display system status code
9. Display chopper temperature
10. Display transformer temperature
11. Display coolant temperature
12. Display coolant flow
13. Display pressure transducers

Required diagnostic elements

These elements provide additional diagnostic capability to the system for troubleshooting gas-delivery problems. The CNC should be capable of executing these commands and displaying the relevant information for the respective test according to the serial protocol guidelines.

14. Test preflow gases
15. Test cutflow gases
16. Inlet leak test
17. System leak test
18. System flow test

CNC screen examples

The screens shown are for reference. The screens you work with may be different, but should include the functions listed on the previous page.

Main (control) screen

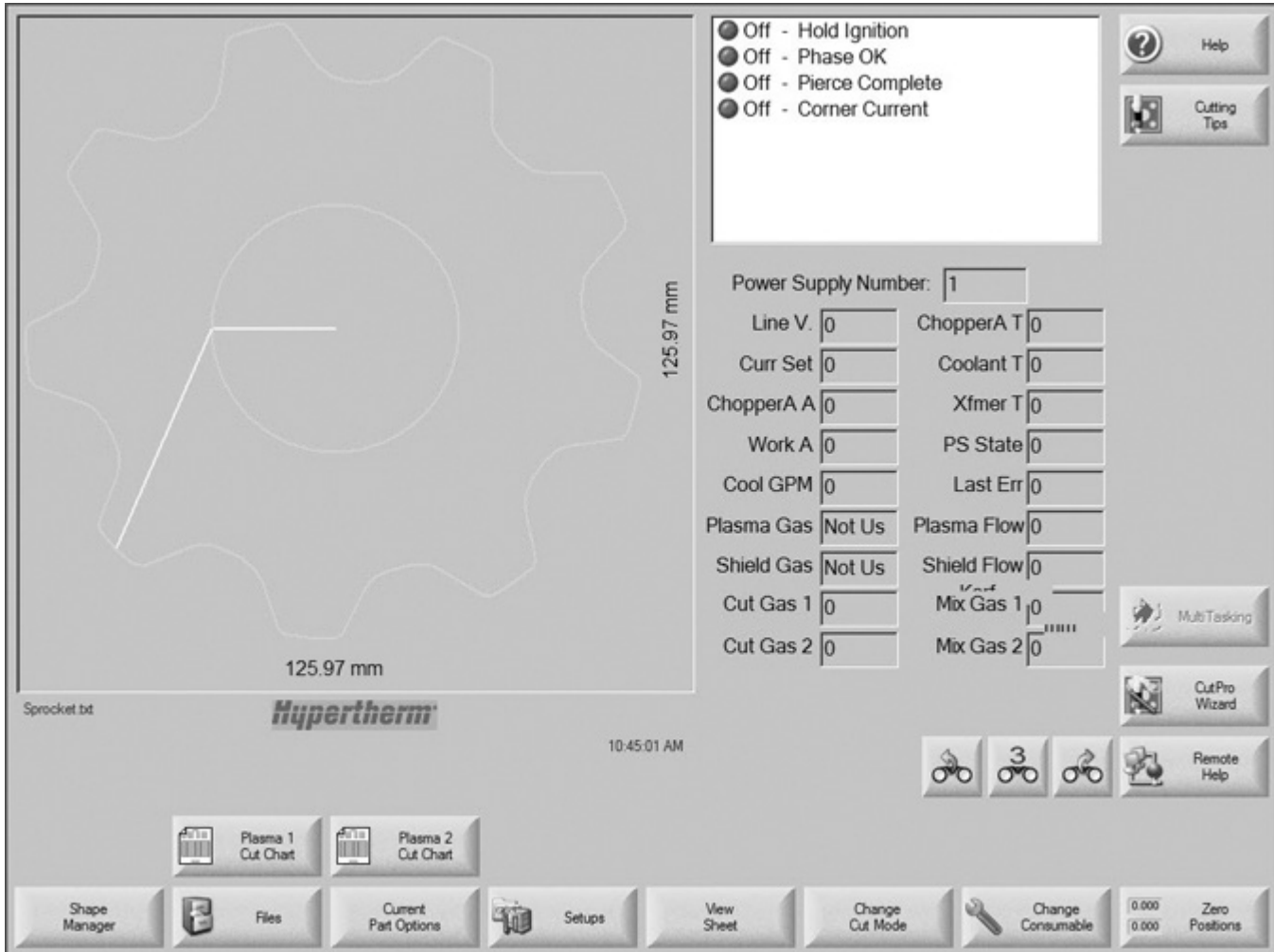

Diagnostic screen

 Help

Power Supply Status		
Line Voltage	123	V 102/138
Current Setpoint	80	Amps
Chopper-A	0	Amps
WorkLead	0	Amps
Coolant Flow	0	GPM 0.7/0.9
PS State Code	14 = Shut Down	
Last 5 Error Codes	0109 0109 0057 0000 0000	

Arc On Statistics		
Arc On Time	653	Seconds
Sys On Time	71	Minutes
Tot Starts	9	Count
Tot Start Errors	319	Count
Tot Ramp Errors	48682	Count

Temperatures		
Chopper A	70.4	F 140/185
Coolant	70.6	F 140/158
Transformer	75.3	F 140/248

Software Revisions		
Power Supply Rev	B.1	
Gas Console Rev	F.	

Gas Types		
Plasma Inlet Gas	Oxygen	
Shield Inlet Gas	Air	

Gas Pressures		
Plasma Cutflow	0	PSI 50/99
Plasma Prewflow	0	PSI 15/99
Shield Cutflow	0	PSI 2/99
Shield Prewflow	0	PSI 2/99

Auto Gas Pressures		
Inlet Cut Gas #1	114	PSI 2/99
Inlet Cut Gas #2	102	PSI 2/99
Mixed Gas #1	131	PSI 2/99
Mixed Gas #2	24	PSI 2/99

9:54:03 AM

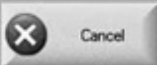

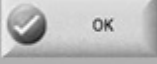

Test Prewflow	Test Cutflow	Test Gas Console	Coolant Override
Power Supply Inputs	Power Supply Outputs	Gas Console Inputs	Gas Console Outputs
			HPR Information

Test screen

The screenshot displays the 'Station 1' test screen with the following components:

- Power Supply Status:** Line Voltage (0 Volts), Current Setpoint (0 Amps), ChopperA (0 Amps), WorkLead (0 Amps), Coolant Flow (0 GPM), PS State Code (0 = Idle), Last Error Code.
- Arc On Statistics:** Arc On Time (0 Seconds), Sys On Time (0 Minutes), Tot Starts (0 Count), Tot Start Errors (0 Count), Tot Ramp Errors (0 Count).
- Temperatures:** ChopperA (0), Coolant (0), Transformer (0).
- Software Revisions:** Power Supply Rev, Gas Console Rev.
- Gas Types:** Plasma Inlet Gas (Not Used), Shield Inlet Gas (Not Used).
- Buttons:** Test Prewlow, Test Outflow, Test Gas Console, Coolant Override, Power Supply Inputs, Power Supply Outputs, Gas Console Inputs, Gas Console Outputs, HPR Information.
- Dialog Box (EDGE Pro):** HPR Gas System Tests with radio buttons for Inlet Leak Check (1 minute) and System Leak Check (1 minute). Includes OK and Cancel buttons.
- Other UI Elements:** Help button, OK/Cancel buttons on the right, and a timestamp of 10:47:22 AM.

Cut chart screen

Plasma 1 Cut Chart - Rev 80006N

HPR - Cut Process Selection

Torch Type **HPR XD**

Material Type **Mild Steel**

Specific Material **None**

Process Current **260A**

Plasma / Shield Gases **O2 / Air**

Material Thickness **10mm**

	Plasma		Shield		
	Auto	Manual	Auto	Manual	
Preflow Setting	<input type="text" value="22"/>	<input type="text" value="24"/>	<input type="text" value="49"/>	<input type="text" value="75"/>	%
Cutflow Setting	<input type="text" value="76"/>	<input type="text" value="70"/>	<input type="text" value="46"/>	<input type="text" value="70"/>	%
	Gas 1		Gas 2		
Mixed Gas	<input type="text" value="0"/>	<input type="text" value="0"/>			%
Cut Speed	<input type="text" value="4572"/>				mmpm
Kerf	<input type="text" value="2.5"/>				mm
Pierce Time	<input type="text" value="0.3"/>				sec
Cut Height Delay	<input type="text" value="0"/>				sec
Creep Time	<input type="text" value="0"/>				sec
Cut Height	<input type="text" value="2.7"/>				mm
Transfer Height	<input type="text" value="300"/>	%	<input type="text" value="8.1"/>	mm	
Pierce Height	<input type="text" value="300"/>	%	<input type="text" value="8.1"/>	mm	
Set Arc Voltage	<input type="text" value="150"/>				volts
Set Arc Current	<input type="text" value="260"/>				amps

10:48:19 AM

Save Process
Reset Process
Save Cut Charts
Load Cut Charts
Change Consumables

Help
Cutting Tips
Cancel
OK
Send Process to HPR

Consumable selection

Standard cutting (0°)

Most of the consumables on the following pages are designed for standard (straight) cutting, when the torch is perpendicular to the workpiece.

Bevel cutting (0° to 45°)

The 80 amp, 130 amp, and 260 amp bevel cutting processes have consumables that are specifically designed for bevel applications. The 400 amp, 600 amp, and 800 amp processes have one set of consumables for both straight cutting and bevel cutting. These consumables use a tapered design that allows them to be used in other applications such as robotic cutting and thick material piercing. Bevel-specific cut charts are provided for all bevel cutting processes.

PowerPierce technology

All bevel consumables have been optimized for PowerPierce, which uses the tapered design to increase pierce capabilities. The 200 amp and 260 amp standard consumables have also been optimized for PowerPierce. Note that the 130 amp standard consumables have not been optimized for PowerPierce. If you wish to pierce thicker material with the 130 amp process, use the 130 amp **bevel-specific** consumables.

Marking

Any of the consumable sets can also be used for marking with argon or nitrogen. Marking parameters are shown at the bottom of each cut chart. The quality of the marks will vary depending on the marking process, cut process, material type, material thickness, and material surface finish. For best mark quality, use the argon marking process settings. For all marking processes the depth of the mark can be increased by reducing the marking speed, or the depth can be decreased by increasing the marking speed. Argon marking currents can be increased by up to 30% to increase the depth of the mark. When marking with an argon process at 25 amps or greater, the process will start with air before changing to argon, and a thicker, darker mark will be seen at the start of the mark. When using the argon marking processes, mark and cut individual parts. Marking the entire nest prior to cutting may lead to reduced consumable life. For better results intersperse cuts and marks. Poor quality marking or burn-through may occur with material less than 1.5 mm (0.06 in or 16 gauge).

Consumables for mirror-image cutting

See the *Parts List* section in this manual for part numbers.

SilverPlus electrodes

SilverPlus electrodes provide increased life when the average cut duration is short (< 60 Seconds), and cut quality is not the most critical requirement. SilverPlus electrodes are available for 80 amp, 130 amp, 200 amp, 260 amp, and 400 amp mild steel O₂ / Air cutting. Part numbers can be found on the following page.

Mild steel

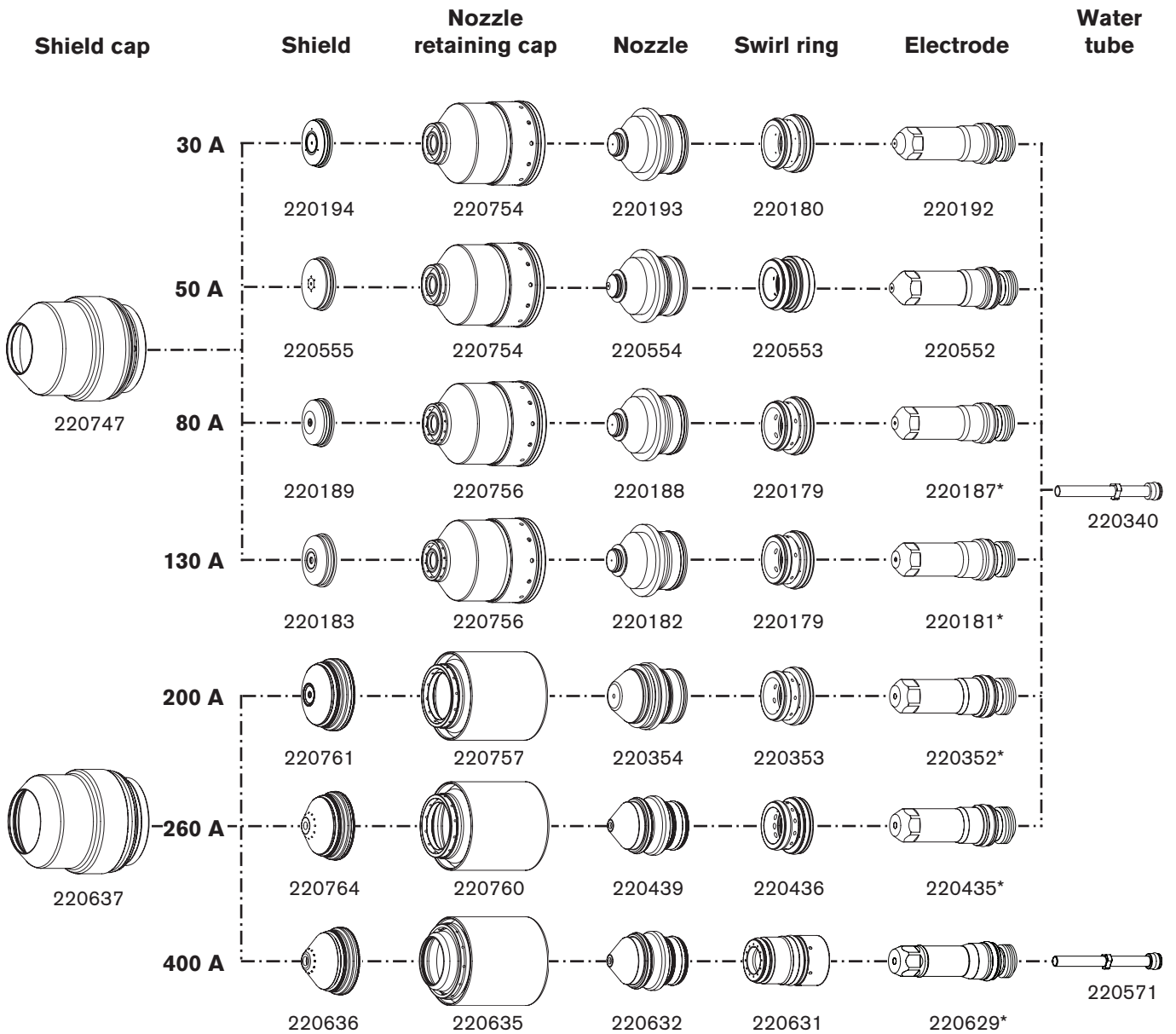

* SilverPlus electrodes are available for these processes:

- Mild steel, 80 amp, O₂ / Air – 420566
- Mild steel, 130 amp, O₂ / Air – 220665
- Mild steel, 200 amp, O₂ / Air – 220666
- Mild steel, 260 amp, O₂ / Air – 220668
- Mild steel, 400 amp, O₂ / Air – 420530

OPERATION

Stainless steel

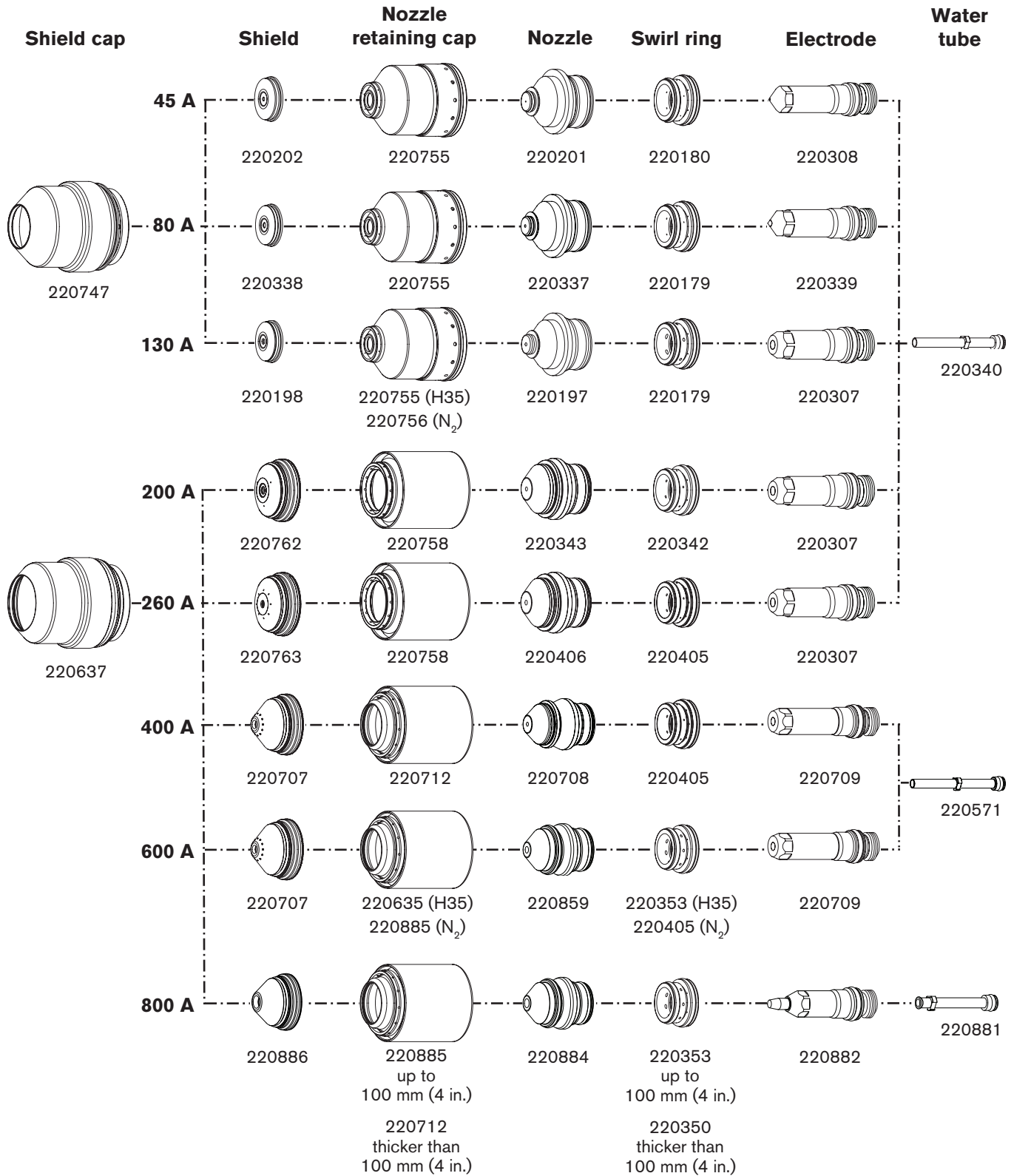

Aluminum

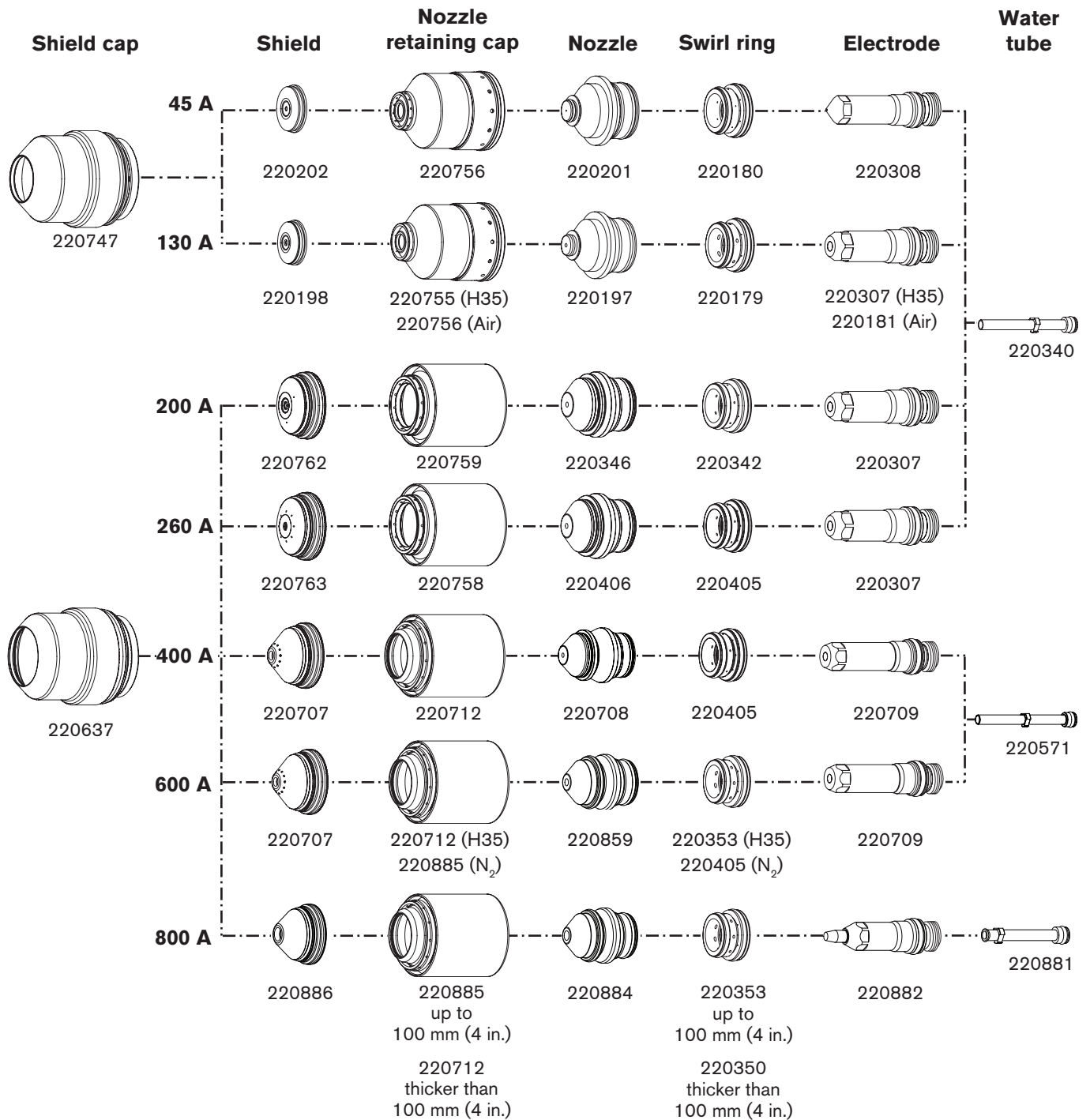

Mild steel bevel cutting

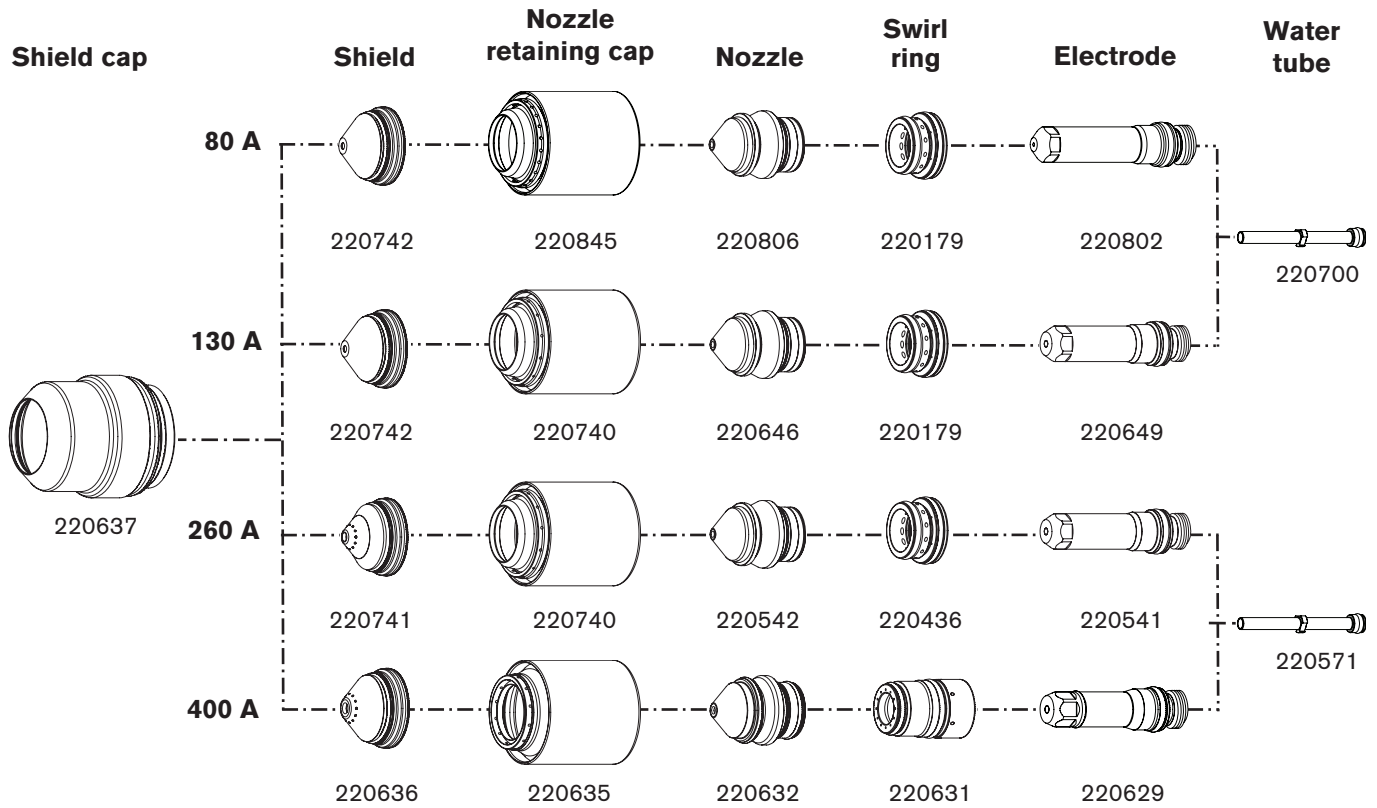

Mild steel, thick piercing, bevel cutting

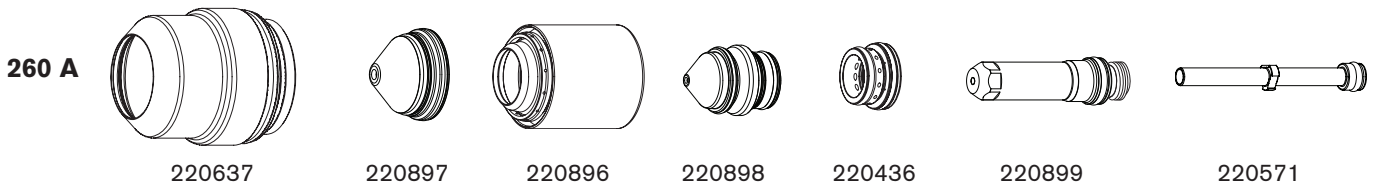

Stainless steel bevel cutting

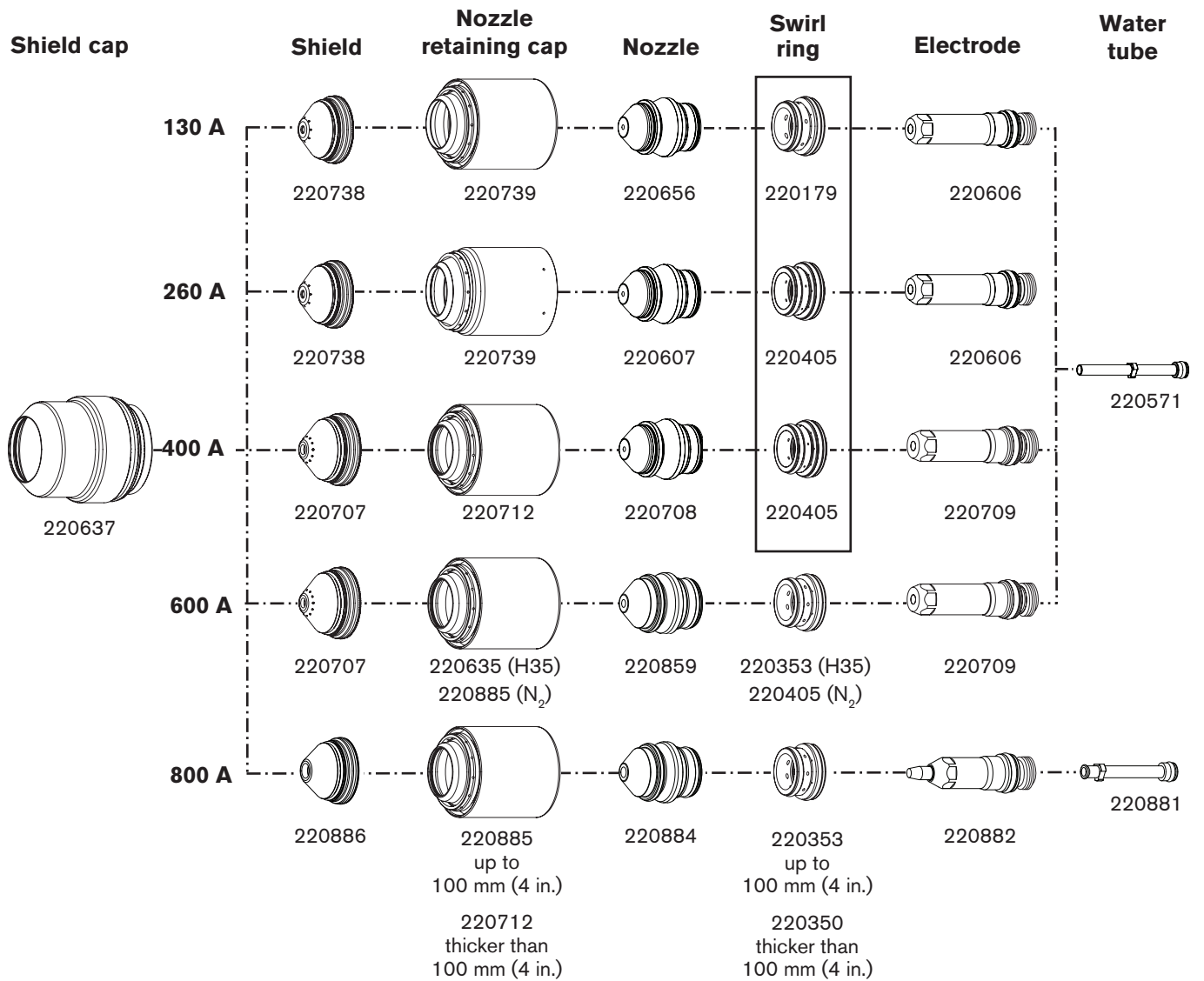

Install and Inspect consumables

		WARNING
<p>The system is designed to go into an idle mode if the retaining cap is removed. However, DO NOT CHANGE CONSUMABLE PARTS WHILE IN THE IDLE MODE. <u>Always</u> disconnect power to the power supply before inspecting or changing torch consumable parts. Use gloves when removing consumables. The torch might be hot.</p>		

Install consumables

Check the consumable parts daily for wear before cutting. Before removing consumables, bring the torch to the edge of the cutting table, with the torch lifter raised to its highest point to prevent the consumables from dropping into the water of the water table.

Note: Do not overtighten parts! Only tighten until mating parts are seated.

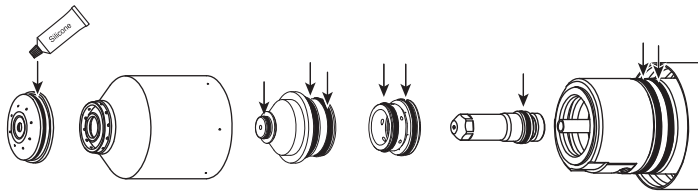

Apply a thin film of silicone lubricant on each o-ring. The o-ring should look shiny, but there should not be any excess or built-up grease.

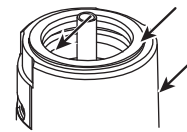

Wipe the internal and external surfaces of the torch with a clean cloth or paper towel.

Tool: 104119

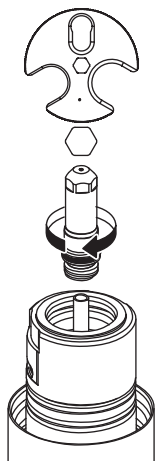

1. Install the electrode



2. Install the swirl ring

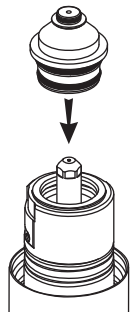

3. Install the nozzle and swirl ring

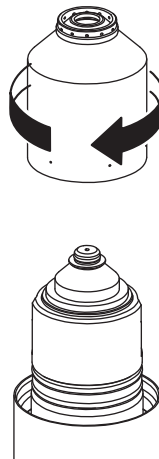

4. Install the nozzle retaining cap

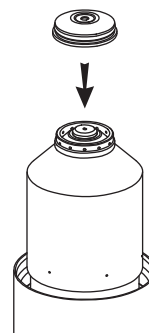

5. Install the shield

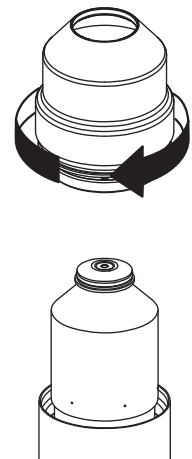

6. Install the shield cap

Remove consumables

Check the consumable parts daily for wear before cutting. Before removing consumables, bring the torch to the edge of the cutting table, with the torch lifter raised to its highest point to prevent the consumables from dropping into the water of the water table.

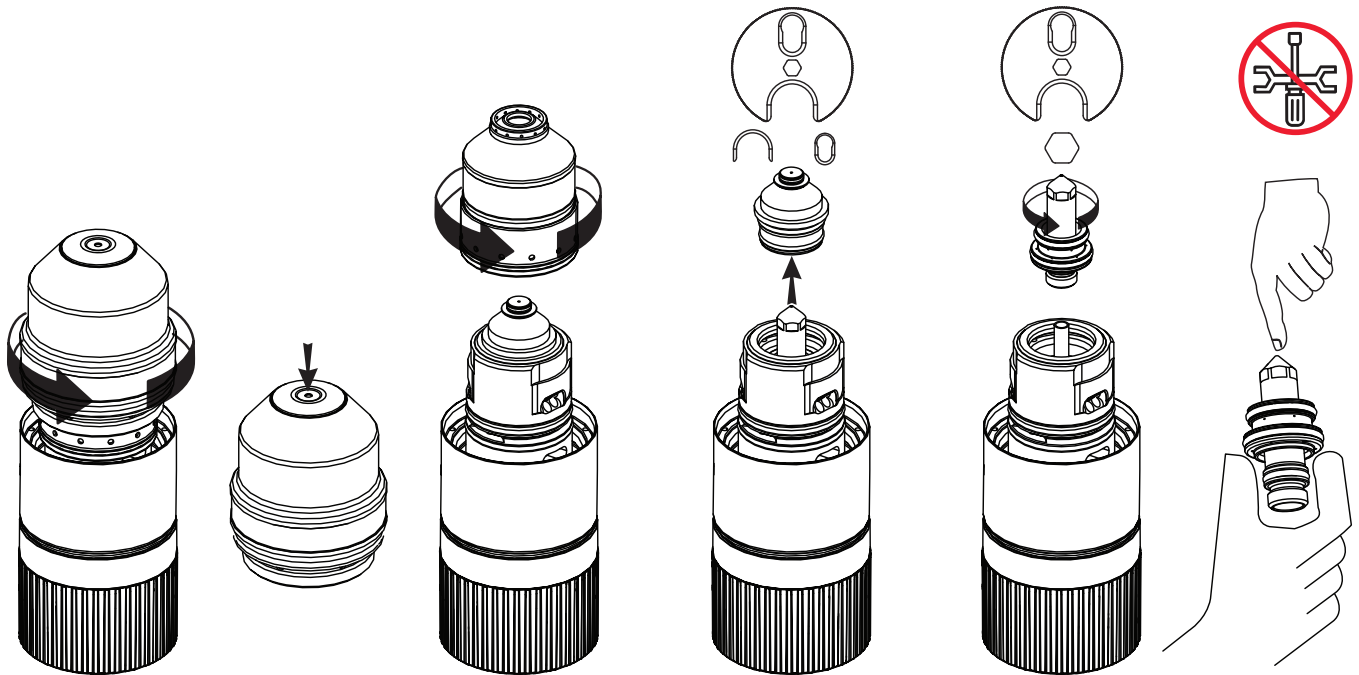

1. Remove the shield and retaining cap assembly.

2. Push the shield out of the retaining cap.

3. Remove the nozzle retaining cap.

4. Remove the nozzle from the torch.

5. Remove the electrode and swirl ring assembly.

6. Hold the base of the swirl ring and push on the electrode to separate the consumables.

OPERATION

Inspect consumables

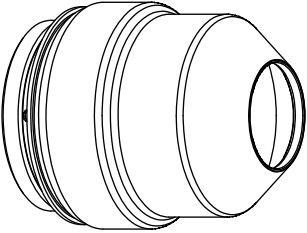
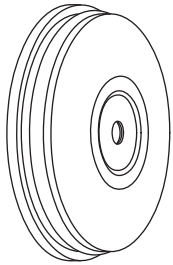
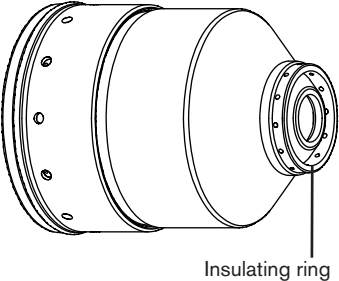
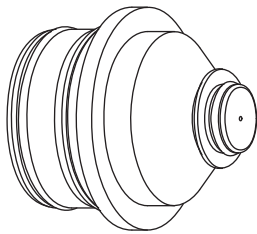
Inspect	Look for	Action
<p>Shield cap</p> 	<p>Erosion, missing material</p> <p>Cracks</p> <p>Burned surface</p>	<p>Replace shield cap</p> <p>Replace shield cap</p> <p>Replace shield cap</p>
<p>Shield</p> 	<p>General: Erosion or missing material</p> <p>Molten material attached</p> <p>Blocked gas holes</p> <p>Center hole: Must be round</p> <p>O-rings: Damage</p> <p>Lubricant</p>	<p>Replace shield</p> <p>Replace shield</p> <p>Replace shield</p> <p>Replace the shield when the hole is no longer round</p> <p>Replace shield</p> <p>Apply a thin film of silicone lubricant if the o-rings are dry</p>
<p>Nozzle retaining cap</p>  <p>Insulating ring</p>	<p>General: Damage to insulating ring</p> <p>Poor cut quality after replacing other consumables</p>	<p>Replace nozzle retaining cap</p> <p>Replace nozzle retaining cap</p>
<p>Nozzle</p> <p>Always replace the nozzle and electrode as a set.</p> 	<p>General: Erosion or missing material</p> <p>Blocked gas holes</p> <p>Center hole: Must be round</p> <p>Signs of arcing</p> <p>O-rings: Damage</p> <p>Lubricant</p>	<p>Replace nozzle</p> <p>Replace nozzle</p> <p>Replace the nozzle when the hole is no longer round</p> <p>Replace nozzle</p> <p>Replace nozzle</p> <p>Apply a thin film of silicone lubricant if the o-rings are dry</p>

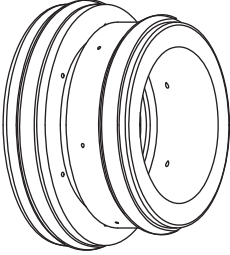
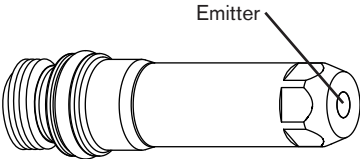
Inspect	Look for	Action
<p>Swirl ring</p> 	<p>General: Chips or cracks Blocked gas holes Dirt or debris</p> <p>O-rings: Damage Lubricant</p>	<p>Replace swirl ring</p> <p>Replace swirl ring</p> <p>Clean and check for damage; replace when damaged</p> <p>Replace swirl ring</p> <p>Apply a thin film of silicone lubricant if the o-rings are dry</p>
<p>Electrode Always replace the nozzle and electrode as a set.</p> 	<p>Center surface: Emitter wear – a pit forms as the emitter wears.</p> <p>O-rings: Damage Lubricant</p>	<p>In general, replace the electrode when the pit depth is 1 mm (0.04 in.) or greater. For the 400 amp mild steel electrode and all SilverPlus electrodes, replace the electrode when the pit depth is 1.5 mm (0.06 in.) or greater. See Electrode pit depth gauge below.</p> <p>Replace electrode</p> <p>Apply a thin film of silicone lubricant if the o-rings are dry</p>

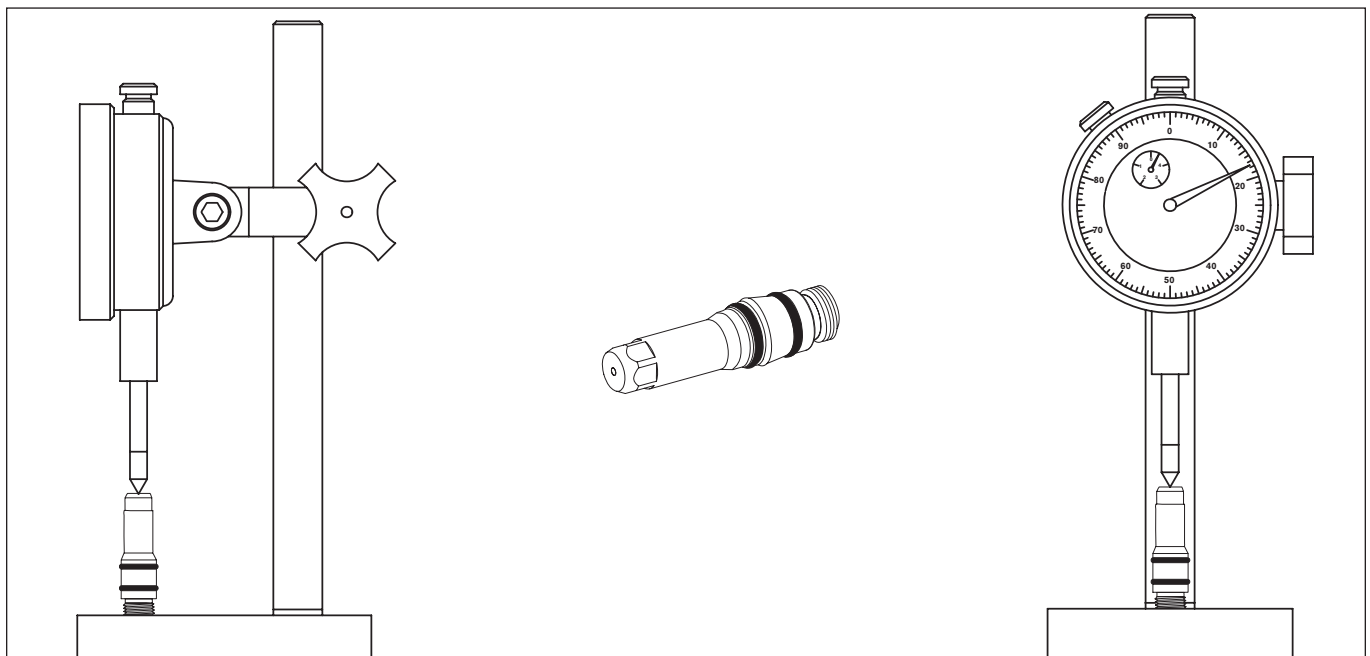

Electrode pit depth gauge (004147)

OPERATION

Torch maintenance

Poor cut quality and premature failure may occur if the HPR torch is not maintained properly.

The torch is manufactured to very tight tolerances to maximize cut quality. The torch should not be subjected to hard impacts that can cause critical features to become misaligned.

The torch should be stored in a clean location when not in use, to avoid contamination of critical surfaces and passages.

Routine maintenance

The following steps should be completed each time consumables are changed:

1. Use a clean cloth to wipe off the torch inside and outside. A cotton swab can be used to access hard-to-reach internal surfaces.
2. Use compressed air to blow away any remaining dirt and debris from internal and external surfaces.
3. Apply a thin film of silicone lubricant on each external o-ring. The o-rings should look shiny, but there should not be any excess or built-up grease.
4. If consumables will be reused, use a clean cloth to wipe them off, and use compressed air to blow them off before they are installed again. This is especially critical for the nozzle retaining cap.

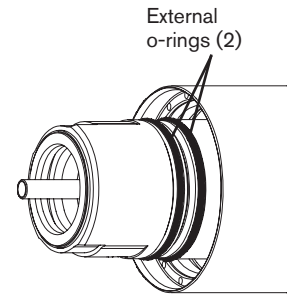

Front view of the torch

Quick-disconnect maintenance

The following steps should be completed every 5-10 times consumables are changed:

1. Remove the torch from the quick-disconnect assembly.
2. Use compressed air to blow off all internal surfaces and the external threads.
3. Use compressed air to blow off all internal surfaces at the rear of the torch.
4. Inspect each of the 5 o-rings at the rear of the torch for nicks or cuts. Replace any damaged o-rings. If they are not damaged, apply a thin film of silicone lubricant on each o-ring. The o-rings should look shiny, but there should not be any excess or built-up grease.

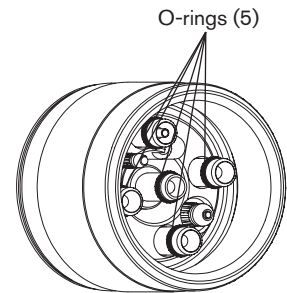
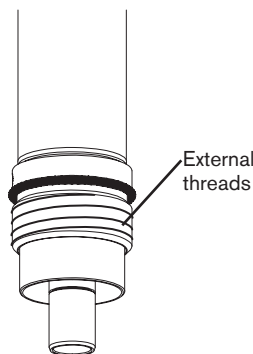

Rear view of the torch

Maintenance kit

Even with proper care, the o-rings at the rear of the torch will need to be replaced periodically. Hypertherm provides a kit (128879) of replacement parts. The kit contains o-rings, a seal, and 2 water tubes. Kits should be kept in stock and be used as part of your routine maintenance schedule.

Torch connections

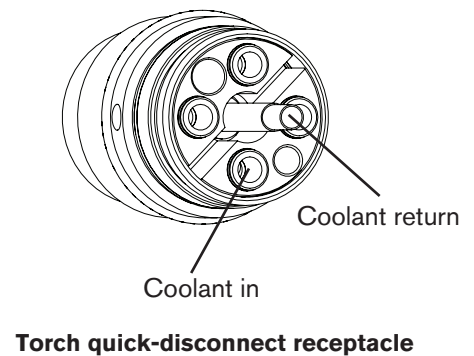
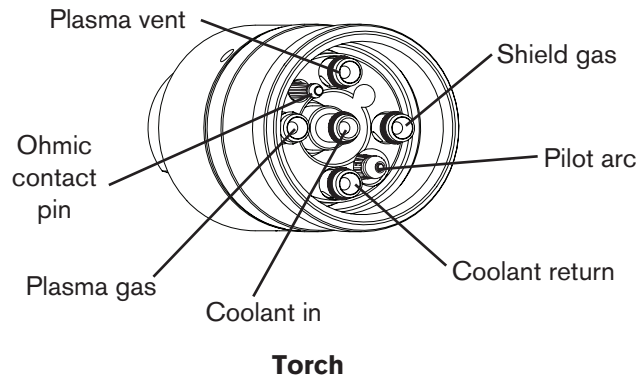

Replace torch water tube

		WARNING
<p>The system is designed to go into an idle mode if the retaining cap is removed. However, DO NOT CHANGE CONSUMABLE PARTS WHILE IN THE IDLE MODE. Always disconnect power to the power supply before inspecting or changing torch consumable parts. Use gloves when removing consumables. The torch might be hot.</p>		

Note: The water tube may seem loose when correctly inserted, but any side-to-side looseness will disappear after the electrode is installed.

1. Turn OFF all power to the system.
2. Remove consumables from torch. See *Install and inspect consumables* in this section.
3. Remove the old water tube.
4. Apply a thin film of silicone lubricant on the o-ring, and install a new water tube. The o-ring should look shiny, but there should not be any excess or built-up grease.
5. Replace consumables. See *Install and inspect consumables* in this section.

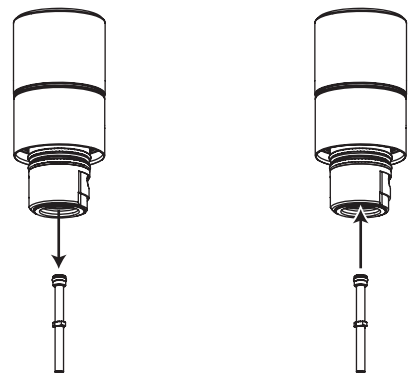

Common cutting faults

- Torch pilot arc will initiate, but will not transfer. Causes can be:
 1. Work cable connection on the cutting table is not making good contact.
 2. Malfunction in the system. See Section 5.
 3. Torch-to-work distance is too high.
- The workpiece is not totally penetrated, and there is excessive sparking on top of the workpiece. Causes can be:
 1. Current is set too low (check *Cut chart* information).
 2. Cut speed is too high (check *Cut chart* information).
 3. Torch parts are worn (see *Install and inspect consumables*).
 4. Metal being cut is too thick.
- Dross forms on the bottom of the cut. Causes can be:
 1. Cutting speed is not correct (check *Cut chart* information).
 2. Arc current is set too low (check *Cut chart* information).
 3. Torch parts are worn (see *Install and inspect consumables*).
- Cut angle is not square. Causes can be:
 1. Wrong direction of machine travel.
High-quality side is on the right with respect to the forward motion of the torch.
 2. Torch-to-work distance is not correct (check *Cut chart* information).
 3. Cutting speed is not correct (check *Cut chart* information).
 4. Arc current is not correct (check *Cut chart* information).
 5. Damaged consumable parts (see *Install and inspect consumables*).
- Short consumable life. Causes can be:
 1. Arc current, arc voltage, travel speed, motion delay, gas flow rates, or initial torch height not set as specified in the *Cut charts*.
 2. Attempting to cut highly magnetic metal plate, such as armor plate with a high nickel content, will shorten consumable life. Long consumable life is difficult to achieve when cutting plate that is magnetized or becomes magnetized easily.
 3. Beginning or ending the cut off the plate surface. **To achieve consumable long life, all cuts must begin and end on the plate surface.**

How to optimize cut quality

The following tips and procedures will help produce square, straight, smooth and dross-free cuts.

Tips for table and torch

- Use a square to align the torch at right angles to the workpiece.
- The torch may travel more smoothly if you clean, check and “tune” the rails and drive system on the cutting table. Unsteady machine motion can cause a regular, wavy pattern on the cut surface.
- The torch must not touch the workpiece during cutting. Contact can damage the shield and nozzle, and affect the cut surface.

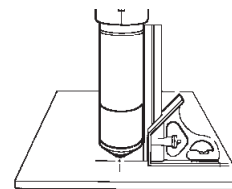

Plasma set-up tips

Follow carefully each step in the *Daily start-up* procedure described earlier in this section.

Purge the gas lines before cutting.

Maximize the life of consumable parts

Hypertherm’s LongLife® process automatically “ramps up” the gas and current flows at the start and ramps them down at the end of each cut, to minimize erosion of the electrode’s center surface. The LongLife process also requires that cuts start and stop on the workpiece.

- The torch should never fire into the air.
 - Starting the cut at the edge of the workpiece is acceptable, as long as the arc is not fired in the air.
 - To start with a pierce, use a pierce height that is 1.5 to 2 times the torch-to-work distance. See *Cut charts*.
- Each cut should end with the arc still attached to the workpiece, to avoid arc blow-outs (ramp-down errors).
 - When cutting drop parts (small parts that drop down after being cut from the workpiece), check that the arc stays attached to the edge of the workpiece, for proper ramp-down.
- If arc blow-outs occur, try one or more of the following:
 - Reduce the cutting speed during the final part of the cut.
 - Stop the arc before the part is completely cut, to allow completion of the cut during the ramp-down.
 - Program the path of the torch into the scrap area for ramp-down.

Note: Use a “chain cut” if possible, so the path of the torch can lead directly from one cut part into the next, without stopping and starting the arc. However, do not allow the path to lead off the workpiece and back on, and remember that a chain cut of long duration will cause electrode wear.

Note: It may be difficult to achieve the full benefits of the LongLife process in some conditions.

Additional factors of cut quality

Cut angle

Note: The squarest cut angle will be on the right side with respect to the forward motion of the torch.

Note: To determine whether a cut-angle problem is being caused by the plasma system or the drive system, make a test cut and measure the angle of each side. Next, rotate the torch 90° in its holder and repeat the process. If the angles are the same in both tests, the problem is in the drive system.

If a cut-angle problem persists after “mechanical causes” have been eliminated (see *Tips for table and torch*, previous page), check the torch-to-work distance, especially if cut angles are all positive or all negative.

- A positive cut angle results when more material is removed from the top of the cut than from the bottom.
- A negative cut angle results when more material is removed from the bottom of the cut.

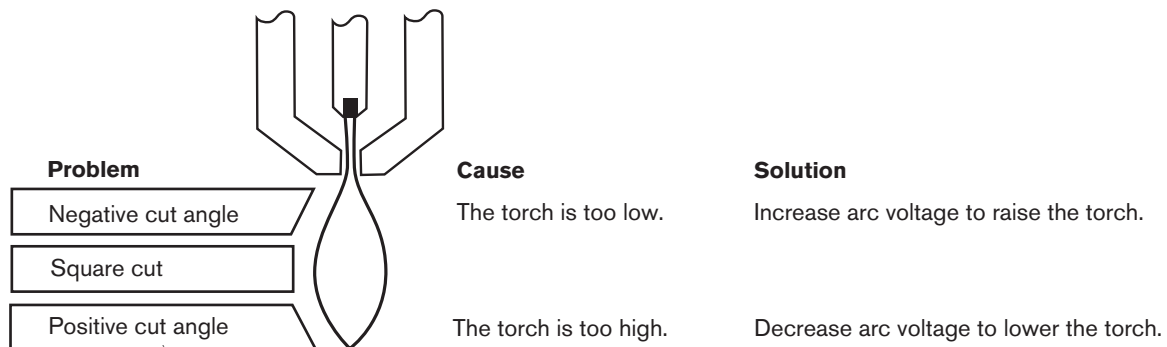

Dross

Low-speed dross forms when the torch's cutting speed is too slow and the arc shoots ahead. It forms as a heavy, bubbly deposit at the bottom of the cut and can be removed easily. Increase the speed to reduce the dross.

High-speed dross forms when the cutting speed is too fast and the arc lags behind. It forms as a thin, linear bead of solid metal attached very close to the cut. It is welded to the bottom of the cut and is difficult to remove. To reduce high-speed dross:

- Decrease the cutting speed.
- Decrease arc voltage, to decrease the torch-to-work distance.

Notes: Dross is more likely to form on warm or hot metal than on cool metal. For example, the first cut in a series of cuts will likely produce the least dross. As the workpiece heats up, more dross may form on subsequent cuts.

Dross is more likely to form on mild steel than on stainless steel or aluminum.

Worn or damaged consumables may produce intermittent dross.

Straightness of the cut surface



A typical plasma cut surface is slightly concave.

The cut surface may become more concave, or convex. Correct torch height is required to keep the cut surface acceptably close to straight.



A strongly concave cut surface occurs when the torch-to-work distance is too low. Increase the arc voltage to increase the torch-to-work distance and straighten the cut surface.



A convex cut surface occurs when the torch-to-work distance is too great or the cutting current is too high. First, reduce the arc voltage, then reduce the cutting current. If there is overlap between different cutting currents for that thickness, try the consumables designed for the lower current.

Additional improvements

Some of these improvements involve trade-offs, as described.

Piercing

The pierce delay should allow sufficient time to penetrate the full thickness of the material, but not so long that it allows the arc to “wander” while trying to find the edge of a large pierce hole. As consumables wear, this delay time may need to be increased. Pierce delay times given in the cut charts are based on average delay times throughout the life of the consumables.

Using the “pierce complete” signal during piercing maintains the shield-gas pressure at the higher preflow pressure, which provides additional protection for the consumables (for example: 30 amp O₂/O₂ and 50 amp O₂/O₂ processes). The pierce complete signal must be turned off for processes with shield gas preflow pressures that are lower than the cutflow pressures (for example: 600 amp and 800 amp processes).

When piercing materials close to the maximum thickness for a specific process, there are several important factors to consider:

- Allow a lead-in distance that is about the same as the thickness of the material being pierced. 50 mm (2 in) material requires a 50 mm lead-in.
- To avoid damage to the shield from the build up of molten material created by the pierce, do not allow the torch to descend to cut height until it has cleared the puddle of molten material.
- When pre-piercing with the 400 amp O₂/air process, the arc should be on for a minimum of 4 seconds or the electrode may experience rapid wear. This 4 seconds allows the current to properly ramp-up and ramp-down which is required for the long life process. A small torch movement may be necessary if the pierce time is less than 4 seconds to keep the arc transferred to the plate.
- Different material chemistries can have an adverse effect on the pierce capability of the system. In particular, high-strength steel and steel with a high manganese or silicon content can reduce the maximum pierce capability. Hypertherm calculates mild steel pierce parameters with certified A-36 plate.
- If the system has difficulty piercing a specific material or thickness, increasing the shield preflow pressure can help in some cases.
Trade-off: This may reduce starting reliability.
- Using a “moving pierce” or “flying pierce” (starting torch motion immediately after transfer and during the pierce process) can extend the piercing capability of the system in some cases. Because this can be a complex process that can damage the torch, lifter, or other components, an edge start is recommended unless the operator is experienced with this technique.

How to increase cutting speed

- Decrease the torch-to-work distance.
Trade-off: This will increase the negative cut angle.

Note: The torch must not touch the workpiece while piercing or cutting.

Cut charts

The following *Cut charts* show the consumable parts, cutting speeds and the gas and torch settings required for each process.

The numbers shown in the *Cut charts* are recommended to provide high-quality cuts with minimal dross. Because of differences between installations and material composition, adjustments may be required to obtain desired results.

Thin stainless steel with HDi technology

Overview

The HPRXD family of plasma cutting systems offers a HyDefinition inox (HDi) 60 A cutting process for thin stainless steel that produces high quality cuts with minimal dross. Specifically, it enables operators to achieve:

- A sharp, top edge of the cut
- A shiny surface finish
- Good cut-edge angularity

You can use these 60 A stainless steel settings with your existing HPRXD system along with the following three new consumables:

- 220814 (nozzle retaining cap)
- 220815 (shield)
- 220847 (nozzle)

The cut charts and consumables for the 60 A stainless steel process can be used with both automatic and manual gas consoles.

Recommendations

Hypertherm develops stainless steel processes using SAE grade 304L. When cutting other grades of stainless steel, you may need to adjust the cut chart parameters to obtain optimal cut quality. In order to reduce the amount of dross, the first recommended adjustment is to adjust the cut speed. Dross can also be reduced by increasing the shield cut flow setting. Both of these adjustments may change the angle of the cut edge.

Cut charts

The HDi charts are listed by amperage with the other stainless steel cut charts.

Thick stainless steel piercing technique

Overview

Hypertherm has developed a technique for extending the stainless steel piercing capability of the HPR400XD and HPR800XD systems:

- The HPR400XD can now perform a moving pierce on stainless steel workpieces 75 mm (3 inches) thick.
- The HPR800XD can now perform a moving pierce on stainless steel workpieces 100 mm (4 inches) thick.

The moving pierce technique (sometimes referred to as a “flying pierce” or “running pierce”) enables operators to cut through thick plates using their plasma systems, without having to resort to other methods such as drilling. It starts torch motion immediately after transfer and during the pierce process.

While the parameters for this moving pierce process are built into Hypertherm’s CNC software and nesting software, the information is available to all HPRXD customers and can be used with other compatible CNCs and nesting software programs.

How moving pierce works



The moving pierce method uses a combination of torch height control, table motion, and plasma current adjustments to form a path in the plate through which the molten metal can flow safely away from the torch. This is accomplished through a series of defined segment lengths and speeds that are synchronized with torch lifter motion. In this way, the molten material can be kept as far from the torch as possible while also maintaining a sustainable arc voltage.

Operators should plan the direction of the moving pierce in their part geometry so that this “rooster tail” of molten metal and hot gases does not get directed at themselves or at the gantry, torch lifter, controller, other torches, or other sensitive equipment. As the molten metal is fed to the side of the torch in the opposite direction of the table motion, most of it gets deposited on top of the plate. Once the arc penetrates the plate, operators can use the standard settings for cutting.

Note: Different material chemistries can have an adverse effect on the pierce capability of the system. The moving pierce settings detailed in this document were developed using 304L stainless steel.

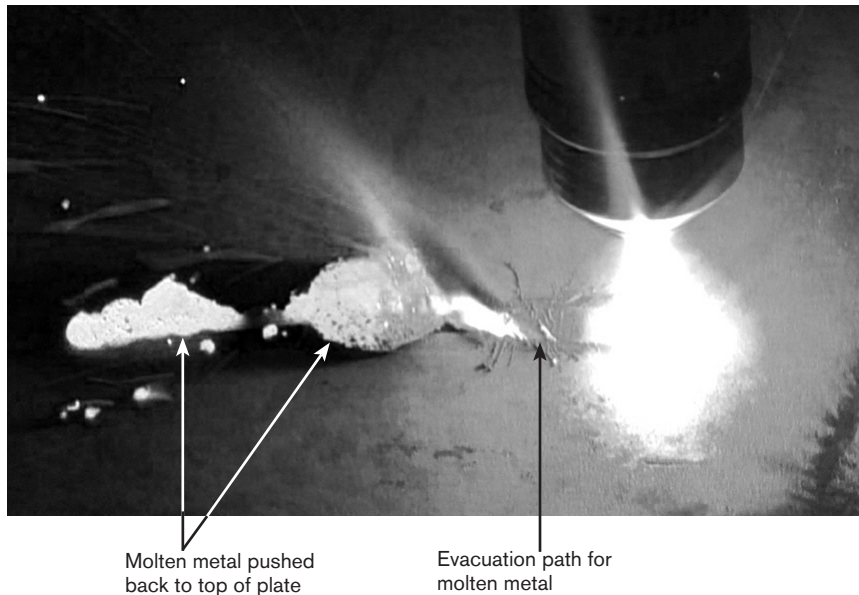
For details on the sequencing involved in coordinating the torch height and table motion in order to perform this type of moving pierce, refer to the *Moving Pierce Technique* white paper (part number 807840), which can be found in the “Downloads library” on the Hypertherm website at www.hypertherm.com. There you can also find a *Thick Metal Cutting Techniques* white paper (part number 807850), which contains technical details on other techniques for cutting thick metal, including the dogleg lead-out technique, that Hypertherm offers as enhancements to its HPRXD systems.



		WARNING
<p>The “rooster tail” of molten material and hot gases produced by this moving pierce technique can result in injury, fire, and damage to equipment if appropriate precautions are not taken.</p> <p>You may be required to use guards to protect operators and to prevent the molten metal from reaching any flammable materials.</p>		

Requirements

- This stainless steel moving pierce technique is specific to the HPR400XD and HPR800XD systems.
- Using this technique with the HPR400XD requires an automatic gas console.
- The “pierce complete” (or “pierce control”) signal must be turned off for these processes when the shield gas preflow pressure is lower than the shield gas outflow pressure.
- This moving pierce technique requires a torch height control (THC) system that is controllable through the CNC.

Moving pierce cut charts

The moving pierce cut charts are listed by amperage with the other stainless steel cut charts. They show the consumable parts, the segment lengths and speeds, and the torch, motion, and plasma current settings that are used to perform the moving pierce for each process.

Once the pierce is complete, cutting can continue with the standard cut chart settings for the 400 A or 800 A stainless steel process as defined in the *Operation* section of your *HPR400XD Instruction Manual* or *HPR800XD Instruction Manual*.

Fine Feature cutting

Overview

Hypertherm has developed the following processes specifically for cutting mild steel in the 3 mm to 25 mm (0.135 to 1 inch) range of thicknesses. These cut chart settings offer a set of optimal parameters for each thickness and are designed to achieve:

- Minimum angle deviation
- A sharp top edge
- A visibly smooth, low-gloss finish

Note: All of these Fine Feature cut chart processes were developed for the automatic gas console.

Benefits and trade-offs

These Fine Feature processes are ideally suited for jobs in which the greatest importance is placed on achieving the best possible finish on the cut surface, a sharp top edge, and tighter control on angle deviation.

When these Factors are not critical, refer to the standard quality cut charts in your HPRXD Instruction Manual, which provide the greatest balance between cut quality and productivity.

In a few cases, two processes are given for a single thickness when performance trade-offs should be considered, such as between the top-edge quality and the angle of the cut. In general, use the lower amperage process for the best edge quality and the higher amperage process for the best dross-free cutting performance.

The Fine Feature processes use standard (straight) cutting consumables designed to work best when the torch is perpendicular to the workpiece. Operators can expect to achieve the same consumable life they currently get using comparable amperage processes with the standard quality cut charts.

Note: The “pierce complete” (or “pierce control”) signal must be turned off when the shield gas preflow pressure is lower than the shield gas cutflow pressure (for example, the 80 A processes in the following cut chart).

Recommendations

- Looping corners can be helpful in achieving sharper corners and in some cases minimizing or eliminating low-speed dross.
- In most cases, these Fine Feature processes employ lower torch-to-work distances than those in the standard quality cut charts, so a flat and properly leveled workpiece will produce optimal results. Pre-piercing and subsequent cleaning of the pierce puddles is recommended, whenever possible.

Cut charts

The Fine Feature cut chart is listed at the beginning of the mild steel cut charts because it has a range of 30 A to 260 A. It is displayed in two separate tables and is sorted by material thickness: the first table lists the consumable part numbers to use for each process (metric and English); the second table shows the cutting speeds and the gas and torch settings required for each process (metric and English).

Note: The marking parameters for the Fine Feature processes covered in this section will be the same as those detailed in the standard quality mild steel cut charts, which are found in the *Operation* section of your HPRXD Instruction Manual.

Bevel cutting

Cut charts

The bevel cut charts are slightly different from the standard cut charts. The torch-to-work distance is a range rather than a single value, material thickness is given as an equivalent value, a column for minimum clearance has been added, and there is no column for arc voltage.

Equivalent thicknesses and the arc voltages will vary depending on the angle of the cut. The angle for bevel cutting can range from 0° to 45°.

Consumables

Bevel cutting processes use separate sets of consumables that are specially designed for bevel applications. These consumables have been optimized for PowerPierce™, which uses the tapered design to increase pierce capabilities.

See the *Parts list* for mirror-image consumable part numbers.

Bevel compensation tables

Customers using bevel heads with an HPRXD plasma-cutting system are now able to use dynamic cut charts (or compensation tables) with compatible CNC and nesting software to achieve more accurate bevel cutting results with mild steel. These specialized cut charts enable operators to retrieve bevel cut settings that are specially tailored for making V cuts, A cuts, and Y Top cuts.

The bevel compensation tables require an HPRXD plasma-cutting system and are intended to be used for cutting mild steel. While these tables are built into Hypertherm's CNC software and nesting software, the information is available to all HPRXD customers and can be used with other compatible CNCs and nesting software programs. For technical details on how to use these compensation tables for mild steel bevel cutting, refer to the HPRXD *Bevel Compensation Cut Charts* white paper (part number 807830), which can be found in the "Downloads library" on the Hypertherm website at www.hypertherm.com.

See *Bevel cutting definitions* on the next page for more detailed information.

Bevel cutting definitions

Bevel angle	The angle between the center line of the torch and a line that is perpendicular to the workpiece. If the torch is perpendicular to the workpiece, the bevel angle is zero. The maximum bevel angle is 45°.
Nominal thickness	The vertical thickness of the workpiece.
Equivalent thickness	The length of the cut edge, or the distance the arc travels through the material while cutting. Equivalent thickness is equal to the nominal thickness divided by the cosine of the bevel angle. Equivalent thicknesses are listed in the cut chart.
Clearance	The vertical distance from the lowest point of the torch to the surface of the workpiece.
Torch-to-work distance	The linear distance from the center of the torch outlet to the workpiece surface along the torch center-line. A range of torch-to-work distances are listed in the cut chart. The smallest number is for a straight cut (bevel angle = 0°). The largest number is for a 45° bevel cut with a clearance of 3 mm (0.120 in).
Arc voltage	The arc voltage setting is dependent on the bevel angle and the setup of the cutting system. The arc voltage setting on one system may be different from a second system even if the workpiece is the same thickness. The arc voltages for bevel cutting are not supplied in the bevel cut charts.

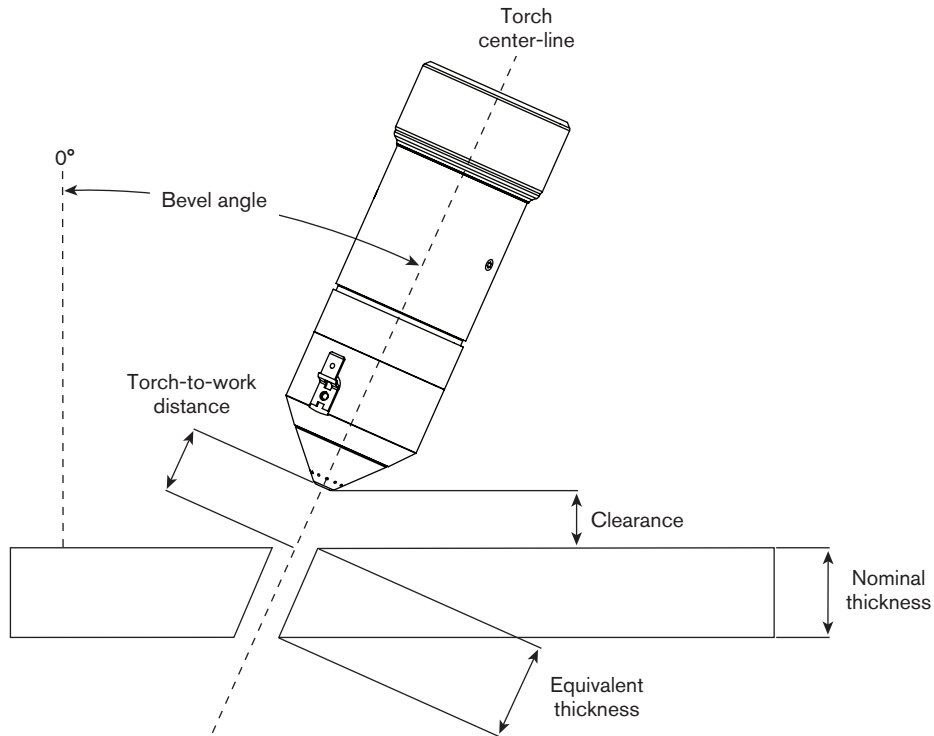

Cutting thick material

There are several important Factors to consider when cutting material that is 100 mm (4 in.) thick or greater:

- **Torch position:** The torch should be positioned just beyond the edge of the plate for best results in attaching the arc to the full edge of the plate
- **Motion delay:** Provide sufficient motion delay to allow the arc and molten material to extend down the majority of the cut edge prior to beginning torch motion
- **Reduced cut speed:** A reduced cut speed may be necessary at the start and at the end of the cut to ensure the arc fully penetrates the entire thickness of the plate
- **Cornering:** A reduced cut speed or a dwell may be necessary when cutting corners of 90 degrees or less to maintain optimum edge flatness
- **Edge quality:** To improve edge flatness when cutting materials over 100 mm (4 in.) with the 800 Amp H35/N₂ process, use the 220350 swirl ring instead of the 220353 and the 220712 nozzle retaining cap instead of the 220885

Underwater cut charts



Overview

Hypertherm has developed underwater cut charts for 80 A, 130 A, 200 A, 260 A, and 400 A mild steel processes. These underwater cut charts are designed to produce optimal results for cutting mild steel up to 75 mm (3 inches) below the surface of the water.

Benefits and trade-offs

Underwater cutting can significantly reduce the level of noise and smoke generated by normal plasma cutting, as well as the glare of the plasma arc. Underwater operation provides the maximum possible noise suppression over the widest possible range of current levels. For example, you can expect noise levels to stay below 70 decibels for many processes when cutting up to 75 mm (3 inches) below the surface of the water. Operators can expect exact noise levels to vary depending on the table design and the cutting application being used.

However, underwater cutting can limit the visual and auditory signals that experienced operators may use while cutting to ensure they are getting a high quality cut and the cutting process is proceeding as it should. Underwater cutting can also affect the cut edge quality, resulting in a rougher surface finish with increased cross levels.

		<p style="text-align: center;">WARNING!</p> <p style="text-align: center;">Explosion hazard – underwater cutting with fuel gases or aluminum</p>
<p>Do not cut under water with fuel gases containing hydrogen. Do not cut aluminum alloys underwater or on a water table unless you can prevent the accumulation of hydrogen gas.</p> <p>Doing so can result in an explosive condition that can detonate during plasma cutting operations.</p>		

All underwater processes (80–400 A) use consumables that are designed for standard (straight) cutting, when the torch is perpendicular to the workpiece.

Requirements and restrictions

- These processes are specifically designed for cutting mild steel up to 75 mm (3 inches) below the surface of the water. Do not attempt to cut in water if the surface of the workpiece is deeper than 75 mm (3 inches).
- The True Hole™ process is not compatible with underwater cutting. If you are using a water table with the True Hole process, the water level should be at least 25 mm (1 inch) below the bottom surface of the workpiece.
- Preflow must be on during initial height sense (IHS) for all underwater cutting.
- Ohmic contact cannot be used for underwater cutting.

Operators should disable ohmic contact from the CNC. For example, if you are using a Hypertherm CNC and torch height control (THC) system, you can disable ohmic contact sensing by switching the Nozzle Contact IHS setting to OFF. The system then defaults to stall force sensing as a backup for torch height control.

The use of stall force sensing is not as accurate as ohmic contact sensing, so operators may need to optimize the stall force setting and/or the cut height setting (or torch-to-work distance) to compensate for possible workpiece deflection. That is, the stall force value should be set high enough to avoid false stall detection but not so high that the excess force causes a deflection of the workpiece and inaccurate IHS operation. In this example, the cut height value can be adjusted from the cut chart, while the stall force value can be adjusted from the THC setup parameters.

Refer to the instruction manuals for your Hypertherm CNC and THC systems for more details on setting the stall force threshold or on disabling ohmic contact. Alternative CNCs and THC systems can also be set up for underwater cutting.

Cut charts

The underwater cut charts are listed by amperage with the other mild steel cut charts.

OPERATION

Estimated kerf-width compensation

The widths in the chart below are for reference. Differences between installations and material composition may cause actual results to vary from those shown in the table.

Metric	Thickness (mm)																											
	1.5	3	5	6	8	10	12	15	20	25	30	32	38	40	45	50	60	65	70	75	80	100	125	150	160			
Mild steel																												
400A O ₂ / Air	N/A	N/A	N/A	N/A	N/A	N/A	N/A	3.40	3.50	3.68	3.76	4.06	N/A	N/A	4.88	5.94	6.60	N/A	7.80	N/A	9.10	N/A	N/A	N/A	N/A	N/A		
260A O ₂ / Air	N/A	N/A	N/A	2.54	2.54	2.54	2.79	3.43	3.56	3.91	3.91	4.32	4.45	N/A	N/A	5.72	N/A	N/A	N/A	N/A	N/A	N/A	N/A	N/A	N/A	N/A		
200A O ₂ / Air	N/A	N/A	1.93	1.98	2.09	2.20	2.26	2.61	2.95	3.16	3.16	4.19	4.87	N/A	N/A	5.45	N/A	N/A	N/A	N/A	N/A	N/A	N/A	N/A	N/A	N/A		
130A O ₂ / Air	N/A	1.64	1.77	1.81	1.92	2.04	2.11	2.22	2.65	3.43	N/A	4.26	4.59	N/A	N/A	N/A	N/A	N/A	N/A	N/A	N/A	N/A	N/A	N/A	N/A	N/A		
80A O ₂ / Air	N/A	1.37	1.53	1.73	1.79	1.91	2.00	2.11	2.72	N/A	N/A	N/A	N/A	N/A	N/A	N/A	N/A	N/A	N/A	N/A	N/A	N/A	N/A	N/A	N/A	N/A		
50A O ₂ / O ₂	1.52	1.74	1.86	1.86	2.09	N/A	N/A	N/A	N/A	N/A	N/A	N/A	N/A	N/A	N/A	N/A	N/A	N/A	N/A	N/A	N/A	N/A	N/A	N/A	N/A	N/A		
30A O ₂ / O ₂	1.35	1.45	1.54	1.56	N/A	N/A	N/A	N/A	N/A	N/A	N/A	N/A	N/A	N/A	N/A	N/A	N/A	N/A	N/A	N/A	N/A	N/A	N/A	N/A	N/A	N/A		
Stainless steel																												
800A H35 / N ₂	N/A	N/A	N/A	N/A	N/A	N/A	N/A	N/A	N/A	N/A	N/A	N/A	N/A	N/A	N/A	11.02	N/A	11.60	N/A	11.90	N/A	13.01	13.43	17.27	17.78	N/A		
600A H35 / N ₂	N/A	N/A	N/A	N/A	N/A	N/A	N/A	N/A	N/A	N/A	N/A	N/A	N/A	8.45	8.67	8.78	9.23	N/A	N/A	N/A	10.78	8.65	N/A	N/A	N/A	N/A		
600A N ₂ / N ₂	N/A	N/A	N/A	N/A	N/A	N/A	N/A	N/A	N/A	N/A	N/A	N/A	N/A	7.33	7.52	7.41	9.29	N/A	N/A	N/A	N/A	N/A	N/A	N/A	N/A	N/A		
400A N ₂ / Air	N/A	N/A	N/A	N/A	N/A	N/A	3.00	2.90	2.80	3.10	3.30	N/A	N/A	5.00	6.00	N/A	N/A	N/A	N/A	N/A	N/A	N/A	N/A	N/A	N/A	N/A		
400A H35 / N ₂	N/A	N/A	N/A	N/A	N/A	N/A	N/A	N/A	5.10	5.30	5.45	N/A	N/A	5.50	N/A	5.80	6.35	N/A	N/A	N/A	N/A	N/A	N/A	N/A	N/A	N/A		
400A H35 & N ₂ / N ₂	N/A	N/A	N/A	N/A	N/A	N/A	3.90	4.00	4.20	4.45	4.65	N/A	N/A	5.15	N/A	5.65	5.90	N/A	6.35	N/A	6.95	N/A	N/A	N/A	N/A	N/A		
260A H35 & N ₂ / N ₂	N/A	N/A	N/A	2.34	3.02	3.71	3.80	3.82	4.32	4.34	N/A	4.58	4.77	N/A	N/A	5.63	N/A	N/A	N/A	N/A	N/A	N/A	N/A	N/A	N/A	N/A		
260A N ₂ / Air	N/A	N/A	N/A	2.31	2.39	2.46	2.54	2.76	3.08	3.30	N/A	3.64	4.43	N/A	N/A	4.16	N/A	N/A	N/A	N/A	N/A	N/A	N/A	N/A	N/A	N/A		
260A H35 / N ₂	N/A	N/A	N/A	N/A	3.84	3.83	3.81	3.81	4.06	4.32	N/A	4.53	4.70	N/A	N/A	7.46	N/A	N/A	N/A	N/A	N/A	N/A	N/A	N/A	N/A	N/A		
200A N ₂ / N ₂	N/A	N/A	N/A	N/A	2.10	2.16	2.29	2.47	2.92	N/A	N/A	N/A	N/A	N/A	N/A	N/A	N/A	N/A	N/A	N/A	N/A	N/A	N/A	N/A	N/A	N/A		
200A H35 / N ₂	N/A	N/A	N/A	N/A	3.66	3.68	3.81	3.68	3.94	N/A	N/A	N/A	N/A	N/A	N/A	N/A	N/A	N/A	N/A	N/A	N/A	N/A	N/A	N/A	N/A	N/A		
200A H35 & N ₂ / N ₂	N/A	N/A	N/A	N/A	3.05	3.05	3.05	2.88	3.30	N/A	N/A	N/A	N/A	N/A	N/A	N/A	N/A	N/A	N/A	N/A	N/A	N/A	N/A	N/A	N/A	N/A		
130A H35 / N ₂	N/A	N/A	N/A	N/A	2.69	2.72	2.77	3.03	2.90	3.25	N/A	N/A	N/A	N/A	N/A	N/A	N/A	N/A	N/A	N/A	N/A	N/A	N/A	N/A	N/A	N/A		
130A N ₂ / N ₂	N/A	N/A	N/A	1.83	1.89	1.88	2.42	2.51	3.00	N/A	N/A	N/A	N/A	N/A	N/A	N/A	N/A	N/A	N/A	N/A	N/A	N/A	N/A	N/A	N/A	N/A		
130A H35 & N ₂ / N ₂	N/A	N/A	N/A	1.78	2.25	2.73	2.76	3.03	2.90	N/A	N/A	N/A	N/A	N/A	N/A	N/A	N/A	N/A	N/A	N/A	N/A	N/A	N/A	N/A	N/A	N/A		
80A F5 / N ₂	N/A	N/A	1.02	1.20	1.05	0.96	N/A	N/A	N/A	N/A	N/A	N/A	N/A	N/A	N/A	N/A	N/A	N/A	N/A	N/A	N/A	N/A	N/A	N/A	N/A	N/A		
45A F5 / N ₂	0.59	0.38	0.52	0.54	N/A	N/A	N/A	N/A	N/A	N/A	N/A	N/A	N/A	N/A	N/A	N/A	N/A	N/A	N/A	N/A	N/A	N/A	N/A	N/A	N/A	N/A		
45A N ₂ / N ₂	0.49	0.23	N/A	N/A	N/A	N/A	N/A	N/A	N/A	N/A	N/A	N/A	N/A	N/A	N/A	N/A	N/A	N/A	N/A	N/A	N/A	N/A	N/A	N/A	N/A	N/A		

Estimated kerf-width compensation - continued

Metric	Thickness (mm)																									
	1.5	3	5	6	8	10	12	15	20	25	30	32	38	40	45	50	60	65	70	75	80	100	125	150	160	
Aluminum	N/A	N/A	N/A	N/A	N/A	N/A	N/A	N/A	N/A	N/A	N/A	N/A	N/A	N/A	N/A	N/A	N/A	N/A	N/A	N/A	N/A	N/A	N/A	N/A	N/A	N/A
800A H35 / N ₂	N/A	N/A	N/A	N/A	N/A	N/A	N/A	N/A	N/A	N/A	N/A	N/A	N/A	N/A	N/A	10.01	N/A	10.62	N/A	12.02	N/A	14.10	15.39	16.64	17.16	
600A H35 / N ₂	N/A	N/A	N/A	N/A	N/A	N/A	N/A	N/A	N/A	N/A	N/A	N/A	N/A	7.19	7.39	7.59	7.99	N/A	N/A	N/A	8.83	8.51	N/A	N/A	N/A	
600A N ₂ / N ₂	N/A	N/A	N/A	N/A	N/A	N/A	N/A	N/A	N/A	N/A	N/A	N/A	9.16	9.81	10.11	10.62	N/A	N/A	N/A	N/A	11.07	N/A	N/A	N/A	N/A	
400A N ₂ / Air	N/A	N/A	N/A	N/A	N/A	N/A	3.50	3.60	3.70	3.90	4.00	N/A	4.00	4.00	7.60	N/A	N/A	N/A	N/A	N/A	N/A	N/A	N/A	N/A	N/A	
400A H35 / N ₂	N/A	N/A	N/A	N/A	N/A	N/A	N/A	N/A	4.20	4.30	4.30	N/A	4.45	4.45	5.40	7.05	N/A	N/A	8.00	N/A	8.15	N/A	N/A	N/A	N/A	
400A H35 & N ₂ / N ₂	N/A	N/A	N/A	N/A	N/A	N/A	3.55	3.65	3.80	3.80	4.20	N/A	4.45	4.45	4.55	6.15	N/A	N/A	6.85	N/A	7.10	N/A	N/A	N/A	N/A	
260A N ₂ / Air	N/A	N/A	N/A	2.49	2.73	2.97	3.05	2.91	3.05	3.30	N/A	2.87	3.99	N/A	N/A	N/A	N/A	N/A	N/A	N/A	N/A	N/A	N/A	N/A	N/A	
260A H35 / N ₂	N/A	N/A	N/A	2.64	2.64	2.62	2.79	3.09	3.30	3.56	N/A	3.29	3.60	N/A	N/A	N/A	N/A	N/A	N/A	N/A	N/A	N/A	N/A	N/A	N/A	
200A N ₂ / N ₂	N/A	N/A	N/A	N/A	1.78	2.03	2.58	2.54	3.01	N/A	N/A	N/A	N/A	N/A	N/A	N/A	N/A	N/A	N/A	N/A	N/A	N/A	N/A	N/A	N/A	
200A H35 / N ₂	N/A	N/A	N/A	N/A	2.44	2.67	2.92	3.18	3.30	N/A	N/A	N/A	N/A	N/A	N/A	N/A	N/A	N/A	N/A	N/A	N/A	N/A	N/A	N/A	N/A	
200A H35 & N ₂ / N ₂	N/A	N/A	N/A	N/A	2.79	2.92	3.05	3.30	3.81	N/A	N/A	N/A	N/A	N/A	N/A	N/A	N/A	N/A	N/A	N/A	N/A	N/A	N/A	N/A	N/A	
130A H35 / N ₂	N/A	N/A	N/A	N/A	2.70	2.72	2.77	2.36	2.90	1.72	N/A	N/A	N/A	N/A	N/A	N/A	N/A	N/A	N/A	N/A	N/A	N/A	N/A	N/A	N/A	
130A Air / Air	N/A	N/A	N/A	2.09	2.09	2.10	2.19	1.91	1.87	2.23	N/A	N/A	N/A	N/A	N/A	N/A	N/A	N/A	N/A	N/A	N/A	N/A	N/A	N/A	N/A	
130A H35 & N ₂ / N ₂	N/A	N/A	N/A	2.06	2.39	2.73	2.76	2.00	2.90	N/A	N/A	N/A	N/A	N/A	N/A	N/A	N/A	N/A	N/A	N/A	N/A	N/A	N/A	N/A	N/A	
45A Air / Air	1.07	1.10	1.25	1.25	N/A	N/A	N/A	N/A	N/A	N/A	N/A	N/A	N/A	N/A	N/A	N/A	N/A	N/A	N/A	N/A	N/A	N/A	N/A	N/A	N/A	

Estimated kerf-width compensation - continued

English
N/A = not available

		Thickness (in.)																				
		0.060	0.135	1/4	5/16	3/8	1/2	5/8	3/4	1	1-1/4	1-1/2	1-3/4	2	2-1/4	2-1/2	3	4	5	6	6-1/4	
Mild steel	400A O ₂ / Air	N/A	N/A	N/A	N/A	N/A	0.135	0.140	0.145	0.148	0.164	0.183	0.215	0.237	0.250	0.275	0.340	N/A	N/A	N/A	N/A	
	260A O ₂ / Air	N/A	N/A	0.100	0.100	0.100	0.110	0.115	0.135	0.150	0.170	0.175	0.220	0.225	0.240	0.260	N/A	N/A	N/A	N/A	N/A	
	200A O ₂ / Air	N/A	N/A	0.078	0.082	0.086	0.089	0.108	0.116	0.125	0.164	0.192	N/A	0.216	N/A	N/A	N/A	N/A	N/A	N/A	N/A	
	130A O ₂ / Air	N/A	0.066	0.071	0.076	0.080	0.083	0.089	0.104	0.135	0.167	0.181	N/A	N/A	N/A	N/A	N/A	N/A	N/A	N/A	N/A	
	80A O ₂ / Air	N/A	0.054	0.068	0.070	0.075	0.080	0.084	0.102	N/A	N/A	N/A	N/A	N/A	N/A	N/A	N/A	N/A	N/A	N/A	N/A	
	50A O ₂ / O ₂	0.060	0.063	0.073	0.082	N/A	N/A	N/A	N/A	N/A	N/A	N/A	N/A	N/A	N/A	N/A	N/A	N/A	N/A	N/A	N/A	N/A
	30A O ₂ / O ₂	0.053	0.057	0.067	N/A	N/A	N/A	N/A	N/A	N/A	N/A	N/A	N/A	N/A	N/A	N/A	N/A	N/A	N/A	N/A	N/A	N/A
		Thickness (in.)																				
		0.060	0.135	1/4	5/16	3/8	1/2	5/8	3/4	1	1-1/4	1-1/2	1-3/4	2	2-1/4	2-1/2	3	4	5	6	6-1/4	
Stainless steel	800A H35 / N ₂	N/A	N/A	N/A	N/A	N/A	N/A	N/A	N/A	N/A	N/A	N/A	N/A	0.435	N/A	0.455	0.470	0.515	0.530	0.680	0.700	
	600A H35 / N ₂	N/A	N/A	N/A	N/A	N/A	N/A	N/A	N/A	N/A	0.330	0.341	0.346	0.346	N/A	0.370	0.440	0.334	N/A	N/A	N/A	
	600A N ₂ / N ₂	N/A	N/A	N/A	N/A	N/A	N/A	N/A	N/A	N/A	0.285	0.297	0.291	0.291	N/A	0.394	0.331	N/A	N/A	N/A	N/A	
	400A N ₂ / Air	N/A	N/A	N/A	N/A	N/A	0.118	0.116	0.112	0.122	0.132	0.198	0.235	N/A	N/A	N/A	N/A	N/A	N/A	N/A	N/A	
	400A H35 / N ₂	N/A	N/A	N/A	N/A	N/A	N/A	N/A	0.200	0.210	0.215	0.218	0.220	0.230	0.245	0.255	N/A	N/A	N/A	N/A		
	400A H35 & N ₂ / N ₂	N/A	N/A	N/A	N/A	N/A	0.135	0.160	0.165	0.175	0.185	0.200	0.210	0.225	0.230	0.235	0.265	N/A	N/A	N/A	N/A	
	260A H35 & N ₂ / N ₂	N/A	N/A	0.092	0.119	0.145	0.151	0.151	0.170	0.171	0.180	0.188	0.197	0.225	N/A	N/A	N/A	N/A	N/A	N/A	N/A	
	260A N ₂ / Air	N/A	N/A	0.091	0.094	0.100	0.100	0.120	0.120	0.130	0.142	0.175	0.223	0.155	N/A	N/A	N/A	N/A	N/A	N/A	N/A	
	260A H35 / N ₂	N/A	N/A	N/A	0.150	0.151	0.165	0.170	0.177	0.182	0.184	0.185	0.202	0.307	N/A	N/A	N/A	N/A	N/A	N/A	N/A	
	200A N ₂ / N ₂	N/A	N/A	N/A	0.083	0.085	0.090	0.090	0.115	N/A	N/A	N/A	N/A	N/A	N/A	N/A	N/A	N/A	N/A	N/A	N/A	
	200A H35 / N ₂	N/A	N/A	N/A	0.144	0.145	0.150	0.152	0.155	N/A	N/A	N/A	N/A	N/A	N/A	N/A	N/A	N/A	N/A	N/A	N/A	
200A H35 & N ₂ / N ₂	N/A	N/A	N/A	0.120	0.120	0.120	0.120	0.130	N/A	N/A	N/A	N/A	N/A	N/A	N/A	N/A	N/A	N/A	N/A	N/A		
130A H35 / N ₂	N/A	N/A	N/A	0.115	0.121	0.123	0.124	0.125	0.129	N/A	N/A	N/A	N/A	N/A	N/A	N/A	N/A	N/A	N/A	N/A		
130A N ₂ / N ₂	N/A	N/A	0.072	0.074	0.083	0.095	0.100	0.118	N/A	N/A	N/A	N/A	N/A	N/A	N/A	N/A	N/A	N/A	N/A	N/A		
130A H35 & N ₂ / N ₂	N/A	N/A	0.070	0.089	0.107	0.109	0.123	0.114	N/A	N/A	N/A	N/A	N/A	N/A	N/A	N/A	N/A	N/A	N/A	N/A		
80A F5 / N ₂	N/A	0.032	0.047	0.050	0.052	N/A	N/A	N/A	N/A	N/A	N/A	N/A	N/A	N/A	N/A	N/A	N/A	N/A	N/A	N/A		
45A F5 / N ₂	0.023	0.015	0.021	N/A	N/A	N/A	N/A	N/A	N/A	N/A	N/A	N/A	N/A	N/A	N/A	N/A	N/A	N/A	N/A	N/A		
45A N ₂ / N ₂	0.019	0.009	0.006	N/A	N/A	N/A	N/A	N/A	N/A	N/A	N/A	N/A	N/A	N/A	N/A	N/A	N/A	N/A	N/A	N/A		

Estimated kerf-width compensation - continued

English	Thickness (in.)																					
	0.060	0.135	1/4	5/16	3/8	1/2	5/8	3/4	1	1-1/4	1-1/2	1-3/4	2	2-1/4	2-1/2	3	4	5	6	6-1/4		
Aluminum																						
800A H35 / N ₂	N/A	N/A	N/A	N/A	N/A	N/A	N/A	N/A	N/A	N/A	N/A	N/A	0.395	N/A	0.410	0.480	0.560	0.610	0.660	0.673		
600A H35 / N ₂	N/A	N/A	N/A	N/A	N/A	N/A	N/A	N/A	N/A	N/A	0.280	0.290	0.300	N/A	0.320	0.350	0.334	N/A	N/A	N/A		
600A N ₂ / N ₂	N/A	N/A	N/A	N/A	N/A	N/A	N/A	N/A	N/A	N/A	0.350	0.385	0.400	N/A	0.425	0.433	N/A	N/A	N/A	N/A		
400A N ₂ / Air	N/A	N/A	N/A	N/A	N/A	0.140	0.143	0.145	0.155	0.160	0.160	0.230	0.300	N/A	N/A	N/A	N/A	N/A	N/A	N/A		
400A H35 / N ₂	N/A	N/A	N/A	N/A	N/A	N/A	N/A	0.164	0.170	0.170	0.170	0.190	0.215	0.250	0.310	0.318	N/A	N/A	N/A	N/A		
400A H35& N ₂ / N ₂	N/A	N/A	N/A	N/A	N/A	0.140	0.145	0.150	0.150	0.170	0.175	0.175	0.180	0.225	0.263	0.276	N/A	N/A	N/A	N/A		
260A N ₂ / Air	N/A	N/A	0.098	0.107	0.120	0.120	0.120	0.120	0.130	0.145	0.158	0.193	0.227	N/A	N/A	N/A	N/A	N/A	N/A	N/A		
260A H35 / N ₂	N/A	N/A	0.104	0.104	0.105	0.110	0.126	0.130	0.140	0.141	0.142	0.222	0.210	N/A	N/A	N/A	N/A	N/A	N/A	N/A		
200A N ₂ / N ₂	N/A	N/A	N/A	0.070	0.080	0.090	0.100	0.105	N/A	N/A	N/A	N/A	N/A	N/A	N/A	N/A	N/A	N/A	N/A	N/A		
200A H35 / N ₂	N/A	N/A	N/A	0.096	0.105	0.115	0.125	0.130	N/A	N/A	N/A	N/A	N/A	N/A	N/A	N/A	N/A	N/A	N/A	N/A		
200A H35& N ₂ / N ₂	N/A	N/A	N/A	N/A	0.115	0.120	0.130	0.150	N/A	N/A	N/A	N/A	N/A	N/A	N/A	N/A	N/A	N/A	N/A	N/A		
130A H35 / N ₂	N/A	N/A	N/A	0.106	0.107	0.109	0.112	0.114	0.120	N/A	N/A	N/A	N/A	N/A	N/A	N/A	N/A	N/A	N/A	N/A		
130A Air / Air	N/A	N/A	0.082	0.082	0.082	0.086	0.071	0.071	0.089	N/A	N/A	N/A	N/A	N/A	N/A	N/A	N/A	N/A	N/A	N/A		
130A H35& N ₂ / N ₂	N/A	N/A	0.081	0.094	0.107	0.109	0.067	0.114	N/A	N/A	N/A	N/A	N/A	N/A	N/A	N/A	N/A	N/A	N/A	N/A		
45A Air / Air	0.042	0.043	0.049	N/A	N/A	N/A	N/A	N/A	N/A	N/A	N/A	N/A	N/A	N/A	N/A	N/A	N/A	N/A	N/A	N/A		

Mild steel Fine Feature Consumables

30 A to 260 A

Metric		Material Thickness	Current	Select Gases		Shield Cap	Shield	Nozzle Retaining Cap	Nozzle	Swirl Ring	Electrode	Water Tube
				Plasma gas	Shield gas							
		mm	Amps			Part Number						
		3	30	O ₂	O ₂	220747	220194	220754	220193	220180	220192	220340
		4				220747	220194	220754	220193	220180	220192	220340
		5				220747	220194	220754	220193	220180	220192	220340
		6				220747	220194	220754	220193	220180	220192	220340
		5	50	O ₂	O ₂	220747	220555	220754	220554	220553	220552	220340
		6				220747	220555	220754	220554	220553	220552	220340
		7	80	Air	Air	220747	220189	220756	220188	220179	220187	220340
		8				220747	220189	220756	220188	220179	220187	220340
		9				220747	220189	220756	220188	220179	220187	220340
		10				220747	220189	220756	220188	220179	220187	220340
		10	130	O ₂	Air	220747	220183	220756	220182	220179	220181	220340
		12				220747	220183	220756	220182	220179	220181	220340
		15	200	O ₂	Air	220637	220761	220757	220354	220353	220352	220340
		16				220637	220761	220757	220354	220353	220352	220340
		20				220637	220761	220757	220354	220353	220352	220340
		20	260	O ₂	Air	220637	220764	220760	220439	220436	220435	220340
		22				220637	220764	220760	220439	220436	220435	220340
		25				220637	220764	220760	220439	220436	220435	220340

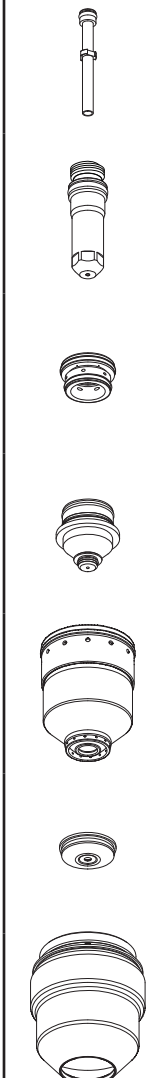

Mild steel Fine Feature Cutting

30 A to 260 A

Metric		Current		Select Gases		Set Preflow		Set Outflow		Arc Voltage	Torch-to-Work Distance	Cutting Speed	Initial Pierce Height		Pierce Delay Time
Material Thickness	mm	Amps	Plasma gas	Shield gas	Plasma gas	Shield gas	Plasma gas	Shield gas	Volts	mm	mm/m	mm	Factor %	Seconds	
3		30	O ₂	O ₂	78	75	94	7	119	1.5	1160	2.7	180	0.5	
4	124														
5	125														
6	128														
5		50	O ₂	O ₂	70	30	81	14	123	1.5	1200	3.0	200	0.4	
6	128														
7		80*	O ₂	Air	48	23	78	25	119	1.5	2286	4.1	267	0.4	
8	121														
9	122														
10	122														
10		130	O ₂	Air	32	32	84	27	129	2.3	2437	6.1	267	0.3	
12	132														
15		200	O ₂	Air	23	42	74	15	130	2.0	1778	8.1	400	0.6	
16	132														
20	157														
20		260	O ₂	Air	22	49	80	47	157	2.3	2032	8.9	389	0.6	
22	162														
25	168														
					84				168		1651		250	0.8	

Note: *The pierce complete signal must be turned off for the 80 A processes.

Mild steel Fine Feature Consumables

30 A to 260 A

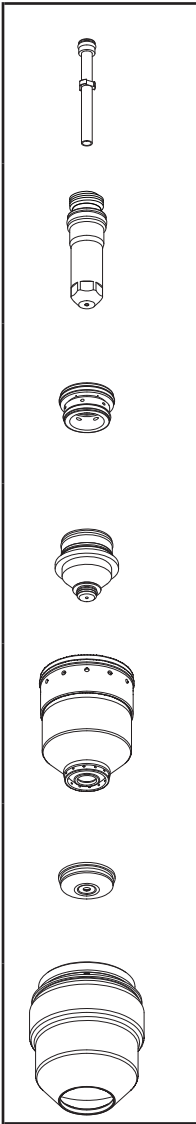
English											
		Material Thickness	Current	Select Gases		Shield Cap	Shield	Nozzle Retaining Cap	Nozzle	Swirl Ring	Electrode
		in	Amps	Plasma gas	Shield gas	Part Number					
	0.135	30	O ₂	O ₂	220747	220194	220754	220193	220180	220192	220340
	3/16										
	1/4	50	O ₂	O ₂	220747	220555	220754	220554	220553	220552	220340
	5/16	80	O ₂	Air	220747	220189	220756	220188	220179	220187	220340
	3/8										
	3/8	130	O ₂	Air	220747	220183	220756	220182	220179	220181	220340
	1/2										
	5/8	200	O ₂	Air	220637	220761	220757	220354	220353	220352	220340
	3/4										
	3/4	260	O ₂	Air	220637	220764	220760	220439	220436	220435	220340
	7/8										
	1										

Mild steel Fine Feature Cutting

30 A to 260 A

English

Material Thickness in	Current Amps	Select Gases		Set Preflow		Set Cutflow		Arc Voltage Volts	Torch-to-Work Distance in	Cutting Speed ipm	Initial Pierce Height		Pierce Delay Time Seconds
		Plasma gas	Shield gas	Plasma gas	Shield gas	Plasma gas	Shield gas				in	Factor %	
0.135 3/16	30	O ₂	O ₂	78	75	94	7	123	0.06	40	0.11	180	0.5
								128					30
1/4	50	O ₂	O ₂	70	30	81	14	125	0.08	35	0.16	200	0.5
5/16 3/8	80*	O ₂	Air	48	23	78	25	119	0.06	90	0.16	267	0.4
								121					70
3/8	130	O ₂	Air	32	32	84	27	128	0.09	98	0.24	267	0.3
1/2	200	O ₂	Air	32	32	25	25	132	0.10	70	0.26	260	0.5
5/8 3/4	200	O ₂	Air	23	42	74	14	130	0.08	70	0.32	400	0.6
							15		356				0.8
3/4	260	O ₂	Air	22	49	80	47	158	0.09	80	0.35	389	0.6
7/8								166	0.14	75	0.35	250	0.7
1						84	49	171					65

Note: *The pierce complete signal must be turned off for the 80 A processes.

OPERATION

Mild steel

O₂ Plasma / O₂ Shield

30 A

Flow rates – lpm/scfh		
	O ₂	Air
Preflow	0 / 0	43 / 90
Cutflow	25 / 52	0 / 0

Note: Air must be connected to use this process. It is used as the preflow gas.

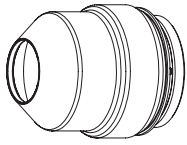

220747



220194

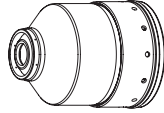

220754

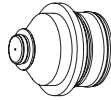

220193



220180

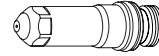

220192

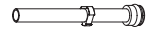

220340

Metric

Select Gases		Set Preflow		Set Cutflow		Material Thickness	Arc Voltage	Torch-to-Work Distance	Cutting Speed	Initial Pierce Height		Pierce Delay Time					
Plasma gas	Shield gas	Plasma gas	Shield gas	Plasma gas	Shield gas	mm	Volts	mm	mm/m	mm	Factor %	Seconds					
O ₂	O ₂	78	17	94	17	0.5	114	1.3	5355	2.3	180	0.1					
						0.8	115		4225			0.2					
						1	116		3615			0.3					
						1.2	117		2865								
						1.5	119		2210								
						2	120		1490								
			35		7	2.5	122	1.5	1325			2.7	1160	0.4			
						3*	123		905				0.5				
						4*	125		665				0.7				
						6*	128						1.0				
						75											

English

Select Gases		Set Preflow		Set Cutflow		Material Thickness	Arc Voltage	Torch-to-Work Distance	Cutting Speed	Initial Pierce Height		Pierce Delay Time		
Plasma gas	Shield gas	Plasma gas	Shield gas	Plasma gas	Shield gas	in	Volts	in	ipm	in	Factor %	Seconds		
O ₂	O ₂	78	17	94	17	0.018	114	0.05	215	0.09	180	0.1		
						0.024			200			0.2		
						0.030			170			0.3		
						0.036			155					
						0.048			110					
						0.060			85					
			35		7	0.075	120	0.06	60			0.11	40	0.4
						0.105	122		50				0.5	
						0.135*	123		30				0.7	
						3/16*	128		25				1.0	
						1/4*								
						75								

Marking

Select Gases		Set Preflow		Set Cutflow		Amperage	Torch-to-Work Distance		Marking Speed		Arc Voltage
						Amps	mm	in	mm/m	ipm	Volts
N ₂	N ₂	10	10	10	10	15	2.5	0.10	6350	250	105
Ar	Air	90	10	90	10	9	2.5	0.10	2540	100	80

* Pierce complete is recommended for these thicknesses.

Mild steel
O₂ Plasma / O₂ Shield
50 A

Flow rates – lpm/scfh		
	O ₂	Air
Preflow	0 / 0	43 / 90
Cutflow	25 / 52	0 / 0

Note: Air must be connected to use this process. It is used as the preflow gas.

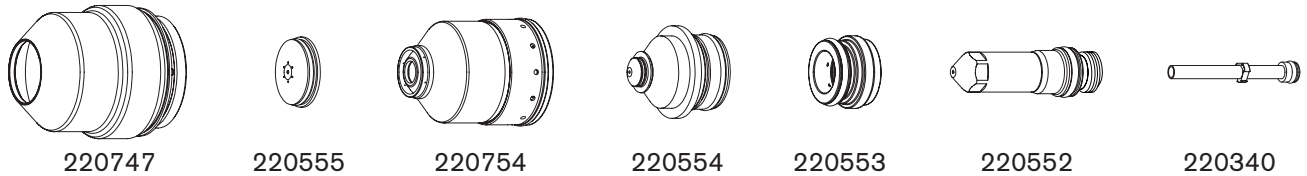

Metric

Select Gases		Set Preflow		Set Cutflow		Material Thickness	Arc Voltage	Torch-to-Work Distance	Cutting Speed	Initial Pierce Height		Pierce Delay Time
Plasma gas	Shield gas	Plasma gas	Shield gas	Plasma gas	Shield gas					mm	Volts	
O ₂	O ₂	70	30	81	14	0.8	110	1.0	6500	2.0	200	0.0
						1	111		5000			
						1.2	112		4150			
						1.5	114	1.3	3200	2.6		
						2	115		2700			
						2.5	117		2200			
						3	119	1.5	1800	3.0		
						4	121		1400			
						5	122		1200			
						6	126		950			
						7	128	2.0	780	4.0		
8	130	630										

English

Select Gases		Set Preflow		Set Cutflow		Material Thickness	Arc Voltage	Torch-to-Work Distance	Cutting Speed	Initial Pierce Height		Pierce Delay Time
Plasma gas	Shield gas	Plasma gas	Shield gas	Plasma gas	Shield gas					in	Volts	
O ₂	O ₂	70	30	81	14	0.030	110	0.04	270	0.08	200	0.0
						0.036			210			
						0.048			160			
						0.060	114	0.05	125	0.10		
						0.075	115		110			
						0.105	118		80			
						0.135	120	0.06	60	0.12		
						3/16	121		50			
						1/4	125	0.08	35	0.16		
						5/16	130		25			

Marking

Select Gases		Set Preflow		Set Cutflow		Amperage	Torch-to-Work Distance		Marking Speed		Arc Voltage
Plasma gas	Shield gas	Plasma gas	Shield gas	Plasma gas	Shield gas		mm	in	mm/m	ipm	
N ₂	N ₂	10	10	10	10	15	2.5	0.10	6350	250	118
Ar	Air	90	10	90	10	9	2.5	0.10	2540	100	77

OPERATION

Mild steel O₂ Plasma / Air Shield 80 A

Flow rates – lpm/scfh		
	O ₂	Air
Preflow	0 / 0	76 / 161
Cutflow	23 / 48	41 / 87

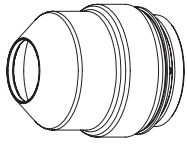

220747



220189

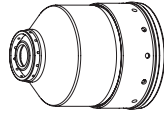

220756

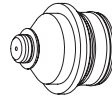

220188



220179

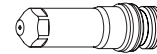

220187

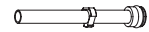

220340

Metric

Select Gases		Set Preflow		Set Cutflow		Material Thickness	Arc Voltage	Torch-to-Work Distance	Cutting Speed	Initial Pierce Height		Pierce Delay Time												
Plasma gas	Shield gas	Plasma gas	Shield gas	Plasma gas	Shield gas					mm	Volts		mm	mm/m	mm	Factor %	Seconds							
O ₂	Air	48	23	78	23	2	112	2.5	9810	3.8	150	0.1												
						2.5	115						2.0	4300	4.0	200								
						3	117										1810	0.2						
						4	120												1410	0.3				
						5	121														1030	0.4		
						6	123																545	0.5
						8	125																	
					10	127	5.0	250	0.7															
					12	130				0.8														
					15	133					0.9													
					20	135	2.5	545	6.3															

English

Select Gases		Set Preflow		Set Cutflow		Material Thickness	Arc Voltage	Torch-to-Work Distance	Cutting Speed	Initial Pierce Height		Pierce Delay Time												
Plasma gas	Shield gas	Plasma gas	Shield gas	Plasma gas	Shield gas					in	Volts		in	ipm	in	Factor %	Seconds							
O ₂	Air	48	23	78	23	0.075	112	0.10	400	0.15	150	0.1												
						0.105	115						0.08	155	0.16	200								
						0.135	117										96	0.2						
						3/16	120												75	0.3				
						1/4	123														50	0.4		
						5/16	125																37	0.5
						3/8	127																	
					1/2	130	0.20	250	0.7															
					5/8	133				0.8														
					3/4	135					0.9													
							0.10	25	0.25															

Marking

Select Gases		Set Preflow		Set Cutflow		Amperage	Torch-to-Work Distance		Marking Speed		Arc Voltage
							mm	in	mm/m	ipm	
N ₂	N ₂	10	10	10	10	15	2.5	0.10	6350	250	130
Ar	Air	50	10	50	10	15	3.0	0.12	2540	100	78

Mild steel bevel cutting

O₂ Plasma / Air Shield

80 A

Flow rates – lpm/scfh		
	O ₂	Air
Preflow	0 / 0	47 / 100
Cutflow	23 / 48	47 / 100

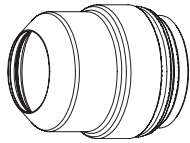

220637



220742

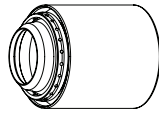

220845

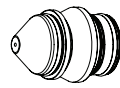

220806



220179



220802



220700

Metric

Select Gases		Set Preflow		Set Cutflow		Minimum Clearance	Equivalent Material Thickness	Torch-to-Work Distance	Cutting Speed	Initial Pierce Height		Pierce Delay Time
Plasma gas	Shield gas	Plasma gas	Shield gas	Plasma gas	Shield gas	mm	mm	Range (mm)	mm/m	mm	Factor %	Seconds
O ₂	Air	48	39	78	39	2.0	2	2.5 – 8.6	9810	3.8	150	0.1
							2.5		7980			
							3		6145			
							4	2.0 – 8.6	4300	4.0	200	0.2
							5		3670			
							6		3045			
					8		2430					
					10		1810					
					12		1410					
					15		1030	5.0	250	0.7		
					20		545	6.3			0.8	
											0.9	

English

Select Gases		Set Preflow		Set Cutflow		Minimum Clearance	Equivalent Material Thickness	Torch-to-Work Distance	Cutting Speed	Initial Pierce Height		Pierce Delay Time
Plasma gas	Shield gas	Plasma gas	Shield gas	Plasma gas	Shield gas	in	in	Range (in)	ipm	in	Factor %	Seconds
O ₂	Air	48	39	78	39	0.08	0.075	0.1 – 0.34	400	0.15	150	0.1
							0.105		290			
							0.135		180			
							3/16	0.08 – 0.34	155	0.16	200	0.2
							1/4		110			
							5/16		96			
					3/8		75					
					1/2		50					
					5/8		37		0.20			
					3/4		25	0.25	0.8			
									0.9			

Marking

Select Gases		Set Preflow		Set Cutflow		Amperage	Torch-to-Work Distance		Marking Speed		Arc Voltage
						Amps	mm	in	mm/m	ipm	Volts
N ₂	N ₂	10	10	10	10	15	2.5	0.10	6350	250	130
Ar	Air	50	10	50	10	15	3.0	0.12	2540	100	78

OPERATION

Flow rates – lpm/scfh		
	O ₂	Air
Preflow	0 / 0	76 / 161
Cutflow	23 / 48	41 / 87

Mild steel underwater cutting

No more than 75 mm (3 in) below the surface of the water

O₂ Plasma / Air Shield

80 A

Note: Preflow must be on during IHS.

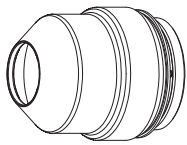

220747



220189

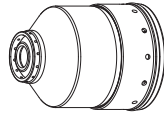

220756

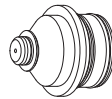

220188



220179

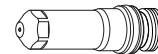

220187



220340

Metric

Select Gases		Set Preflow		Set Cutflow		Material Thickness	Arc Voltage	Torch-to-Work Distance	Cutting Speed	Initial Pierce Height		Pierce Delay Time		
Plasma gas	Shield gas	Plasma gas	Shield gas	Plasma gas	Shield gas					mm	Volts		mm	mm
O ₂	Air	48	23	78	23	4	116	2.0	3877	4.0	200	0.2		
						5	118		3407			0.3		
						6	122		2746			0.4		
						8	125		2162			0.5		
						10	129		1639			0.7		
					10	12	132		1271			5.0	250	0.7
						15	136		922			5.0	250	0.8

English

Select Gases		Set Preflow		Set Cutflow		Material Thickness	Arc Voltage	Torch-to-Work Distance	Cutting Speed	Initial Pierce Height		Pierce Delay Time		
Plasma gas	Shield gas	Plasma gas	Shield gas	Plasma gas	Shield gas					inches	Volts		inches	ipm
O ₂	Air	48	23	78	23	0.135	115	0.10	162	0.16	200	0.2		
						3/16	117		140			0.3		
						1/4	123		99			0.4		
						5/16	125		86			0.5		
						3/8	128		68			0.7		
					10	1/2	133		45			0.20	250	0.7
						5/8	137		33			0.20	250	0.8

Mild steel
O₂ Plasma / Air Shield
130 A

Flow rates – lpm/scfh		
	O ₂	Air
Preflow	0 / 0	102 / 215
Cutflow	33 / 70	45 / 96

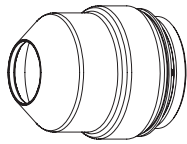

220747



220183

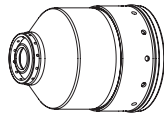

220756

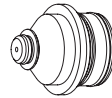

220182



220179

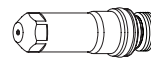

220181

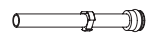

220340

Metric

Select Gases		Set Preflow		Set Cutflow		Material Thickness	Arc Voltage	Torch-to-Work Distance	Cutting Speed	Initial Pierce Height		Pierce Delay Time
Plasma gas	Shield gas	Plasma gas	Shield gas	Plasma gas	Shield gas					mm	Volts	
O ₂	Air	32	32	84	28	3	124	2.5	6505	5.0	200	0.1
						4	126	2.8	5550	0.2		
						5			4795			
					6	127	4035	6.0	0.3			
					22	8	129			3.0		3360
						10	130			2680		
			12	132		3.3	2200	6.6	0.5			
			52	20	138	3.8	1665	7.6	1.0			
										25		141
				32	160	4.5	375	Edge start				
										38		167

English

Select Gases		Set Preflow		Set Cutflow		Material Thickness	Arc Voltage	Torch-to-Work Distance	Cutting Speed	Initial Pierce Height		Pierce Delay Time
Plasma gas	Shield gas	Plasma gas	Shield gas	Plasma gas	Shield gas					in	Volts	
O ₂	Air	32	32	84	28	0.135	124	0.10	240	0.20	200	0.1
						3/16	126	0.11	190	0.22		0.2
						1/4			127	150		
					22	5/16	129	0.12	132	0.24		0.3
						3/8	130	110				
						1/2	132	0.13	80			
			52	3/4	138	0.15	60	0.30	1.0			
							1			141		0.16
				1-1/4	160	0.18	15	Edge start				
										1-1/2		167

Marking

Select Gases		Set Preflow		Set Cutflow		Amperage	Torch-to-Work Distance		Marking Speed		Arc Voltage
N ₂	N ₂						mm	in	mm/m	ipm	
N ₂	N ₂	10	10	10	10	15	2.5	0.10	6350	250	130
Ar	Air	50	10	50	10	15	3.0	0.12	2540	100	75

OPERATION

Mild steel bevel cutting

O₂ Plasma / Air Shield

130 A

Flow rates – lpm/scfh		
	O ₂	Air
Preflow	0 / 0	64 / 135
Cutflow	33 / 70	45 / 96

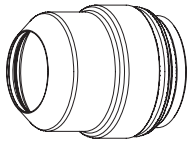

220637



220742

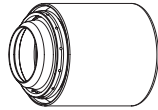

220740

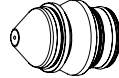

220646



220179



220649

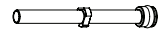

220700

Note: Bevel angle range is 0° to 45°.

Metric

Select Gases		Set Preflow		Set Cutflow		Minimum Clearance	Equivalent Material Thickness	Torch-to-Work Distance	Cutting Speed	Initial Pierce Height		Pierce Delay Time	
Plasma gas	Shield gas	Plasma gas	Shield gas	Plasma gas	Shield gas					mm	mm		Range (mm)
O ₂	Air	15**	23	84	21	2.0	3	2.5 – 8.6	6505	5.0	200	190	0.1
							4						5550
							5	2.8 – 8.6	4795	5.6			0.3
							6		4035				
							8		3.0 – 8.6				
							10	2680		6.0			
			12	3.3 – 8.6	2200		6.6	0.5					
			15		3.8 – 8.6				1665	7.6	0.7		
			20	1050									
			25	550									
			32*	4.5 – 8.6	375		10.2	220	1.8	1.0			
			38		255					1.8			
			Edge start										

English

Select Gases		Set Preflow		Set Cutflow		Minimum Clearance	Equivalent Material Thickness	Torch-to-Work Distance	Cutting Speed	Initial Pierce Height		Pierce Delay Time				
Plasma gas	Shield gas	Plasma gas	Shield gas	Plasma gas	Shield gas					in	in		Range (in)	ipm	in	Factor %
O ₂	Air	15**	23	84	21	0.08	0.135	0.10 – 0.34	240	0.20	200	190	0.1			
							3/16						190	0.2		
							1/4	0.11 – 0.34	150	0.22			0.3			
							5/16		132							
							3/8							110		
							1/2	0.12 – 0.34	80	0.24			0.5			
			5/8	0.13 – 0.34	60		0.30		0.7							
			3/4		0.15 – 0.34			45								
			1					20		0.30	1.0					
			1-1/4*	0.16 – 0.34	15		0.40	1.8								
			1-1/2		20				1.8							
			Edge start												4.0	

Marking

Select Gases		Set Preflow		Set Cutflow		Amperage	Torch-to-Work Distance		Marking Speed		Arc Voltage
Plasma gas	Shield gas	Plasma gas	Shield gas	Plasma gas	Shield gas		Amps	mm	in	mm/m	
N ₂	N ₂	10	10	10	10	15	2.5	0.10	6350	250	130
Ar	Air	50	10	50	10	15	3.0	0.12	2540	100	75

* Suggestions for piercing 32 mm (1-1/4 in) mild steel: 1. Turn preflow on during IHS, 2. Use ohmic contact during IHS, 3. Use pierce complete when piercing.

** Some configurations may require 20 psi plasma preflow gas setpoint if you experience excessive Error 44 codes.

Flow rates – lpm/scfh		
	O ₂	Air
Preflow	0 / 0	102 / 215
Cutflow	33 / 70	45 / 96

Mild steel underwater cutting

No more than 75 mm (3 in) below the surface of the water

O₂ Plasma / Air Shield

130 A

Note: Preflow must be on during IHS.

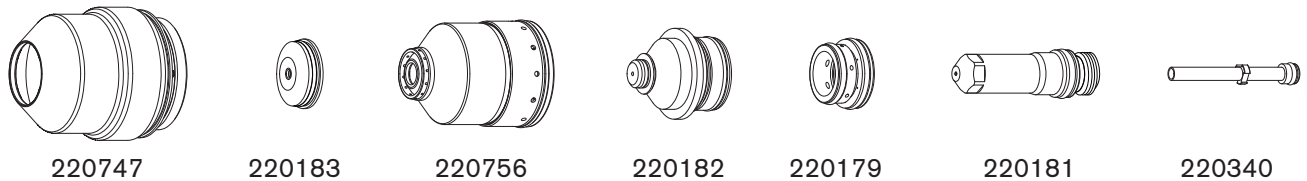

Metric

Select Gases		Set Preflow		Set Cutflow		Material Thickness	Arc Voltage	Torch-to-Work Distance	Cutting Speed	Initial Pierce Height		Pierce Delay Time
Plasma gas	Shield gas	Plasma gas	Shield gas	Plasma gas	Shield gas					mm	Volts	
O ₂	Air	32	32	84	28	5	127	2.8	4212	5.6	200	0.3
					22	8	129	3.0	2998	6.0		
						10	131	3.3	2412	6.6		
						12	133	3.8	1980	7.6		
15	138		1497									

English

Select Gases		Set Preflow		Set Cutflow		Material Thickness	Arc Voltage	Torch-to-Work Distance	Cutting Speed	Initial Pierce Height		Pierce Delay Time
Plasma gas	Shield gas	Plasma gas	Shield gas	Plasma gas	Shield gas					inches	Volts	
O ₂	Air	32	32	84	28	3/16	127	0.11	171	0.22	200	0.2
						1/4	126		135			
					22	5/16	129	0.12	119	0.24		
			3/8			130	99					
			1/2			134	72					
			52		22	140	0.15	54	0.30			
3/4	144	41										

OPERATION

Mild steel O₂ Plasma / Air Shield 200 A

Flow rates – lpm/scfh		
	O ₂	Air
Preflow	0 / 0	128 / 270
Cutflow	39 / 82	48 / 101

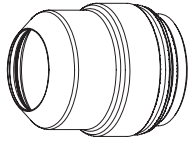

220637



220761

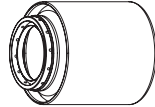

220757

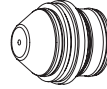

220354



220353

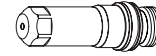

220352

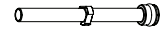

220340

Metric

Select Gases		Set Preflow		Set Cutflow		Material Thickness	Arc Voltage	Torch-to-Work Distance	Cutting Speed	Initial Pierce Height		Pierce Delay Time						
Plasma gas	Shield gas	Plasma gas	Shield gas	Plasma gas	Shield gas					mm	Volts		mm	mm/m	mm	Factor %	Seconds	
O ₂	Air	23	42	74	18	5	123	3.3	5700	6.6	200	0.2						
						6	124						4355	0.3				
						8	125								3460	0.5		
						10	126										3060	0.6
						12	128											
						15	131	4.1	1575	8.2		1.0						
						20	133						5.1	1165	10.2	Edge start		
						25	143	750										
						32	145		510									
						38	152			255								
						50	163											

English

Select Gases		Set Preflow		Set Cutflow		Material Thickness	Arc Voltage	Torch-to-Work Distance	Cutting Speed	Initial Pierce Height		Pierce Delay Time						
Plasma gas	Shield gas	Plasma gas	Shield gas	Plasma gas	Shield gas					in	Volts		in	ipm	in	Factor %	Seconds	
O ₂	Air	23	42	74	18	3/16	124	0.13	230	0.26	200	0.2						
						1/4							171	0.3				
						5/16									140	0.5		
						3/8											115	0.6
						1/2												
						5/8	131	0.16	65	0.32		1.0						
						3/4							143	0.20	45	0.40	Edge start	
						1	30											
						1-1/4		20										
						1-1/2			10									
						2												

Marking

Select Gases		Set Preflow		Set Cutflow		Amperage	Torch-to-Work Distance		Marking Speed		Arc Voltage
Plasma gas	Shield gas	Plasma gas	Shield gas	Plasma gas	Shield gas		mm	in	mm/m	ipm	
N ₂	N ₂	10	10	10	10	15	2.5	0.10	6350	250	130
Ar	Air	30	10	30	10	20	3.0	0.12	2540	100	63

Mild steel bevel cutting

O₂ Plasma / Air Shield

200 A

Flow rates – lpm/scfh		
	O ₂	Air
Preflow	0 / 0	114 / 240
Cutflow	43 / 90	49 / 102

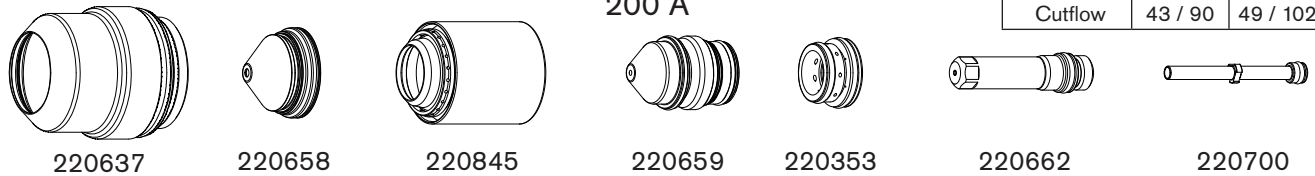

Note: For mirror-image cutting, use 220996 (nozzle retaining cap) and 220350 (swirl ring) instead.

Metric

Select Gases		Set Preflow		Set Cutflow		Minimum Clearance	Equivalent Material Thickness	Torch-to-Work Distance	Cutting Speed	Initial Pierce Height		Pierce Delay Time
Plasma gas	Shield gas	Plasma gas	Shield gas	Plasma gas	Shield gas	mm	mm	Range (mm)	mm/m	mm	Factor %	Seconds
O ₂	Air	23	83	69	42	2.0	5	3.3 – 8.4	5700	6.6	200	0.2
							6		5250			
							8		4355			
							10		3460			
							12		3060			
							15	4.1 – 8.4	2275	8.2	0.6	
							20		1575			
							25	5.1 – 8.4	1165	10.2	0.8	
							32		750			
							38		510			
50	255											
Edge start												

English

Select Gases		Set Preflow		Set Cutflow		Minimum Clearance	Equivalent Material Thickness	Torch-to-Work Distance	Cutting Speed	Initial Pierce Height		Pierce Delay Time
Plasma gas	Shield gas	Plasma gas	Shield gas	Plasma gas	Shield gas	in	in	Range (in)	ipm	in	Factor %	Seconds
O ₂	Air	23	83	69	42	0.08	3/16	0.13 – 0.33	230	0.26	200	0.2
							1/4		200			
							5/16		171			
							3/8		140			
							1/2		115			
							5/8	0.16 – 0.33	80	0.32	0.5	
							3/4		65			
							1	0.20 – 0.33	45	0.40	0.8	
							1-1/4		30			
							1-1/2		20			
2	10	Edge start										

Marking

Select Gases		Set Preflow		Set Cutflow		Amperage	Torch-to-Work Distance		Marking Speed		Arc Voltage
						Amps	mm	in	mm/m	ipm	Volts
N ₂	N ₂	10	10	10	10	15	2.5	0.10	6350	250	124
Ar	Air	30	10	30	10	20	3.0	0.12	2540	100	61

OPERATION

Flow rates – lpm/scfh		
	O ₂	Air
Preflow	0 / 0	128 / 270
Cutflow	39 / 82	48 / 101

Mild steel underwater cutting

No more than 75 mm (3 in) below the surface of the water

O₂ Plasma / Air Shield

200 A

Note: Preflow must be on during IHS.



Metric

Select Gases		Set Preflow		Set Cutflow		Material Thickness	Arc Voltage	Torch-to-Work Distance	Cutting Speed	Initial Pierce Height		Pierce Delay Time
Plasma gas	Shield gas	Plasma gas	Shield gas	Plasma gas	Shield gas					mm	Volts	
O ₂	Air	23	42	74	18	8	126	3.3	3878	6.6	200	0.3
						10	127		3116			
						12	129		2764			
						15	133	4.1	2052	8.2	0.6	

English

Select Gases		Set Preflow		Set Cutflow		Material Thickness	Arc Voltage	Torch-to-Work Distance	Cutting Speed	Initial Pierce Height		Pierce Delay Time
Plasma gas	Shield gas	Plasma gas	Shield gas	Plasma gas	Shield gas					inches	Volts	
O ₂	Air	23	42	74	18	1/4	125	0.13	180	0.26	200	0.2
						5/16	126		154			
						3/8	127		126			
						1/2	129		104			
						5/8	135	0.16	72	0.32	0.6	
						3/4	137		59			

Mild steel
O₂ Plasma / Air Shield
260 A

Flow rates – lpm/scfh		
	O ₂	Air
Preflow	0 / 0	130 / 275
Cutflow	42 / 88	104 / 220

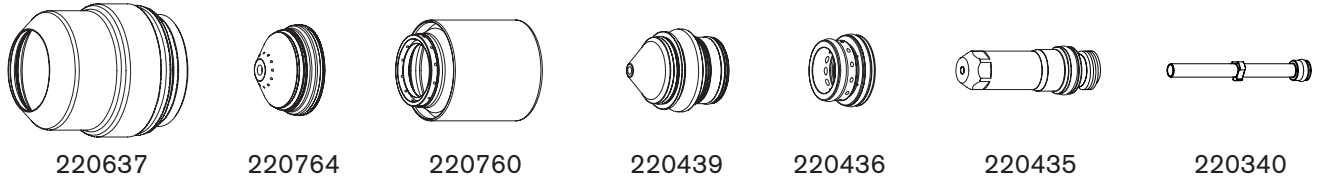

Metric

Select Gases		Set Preflow		Set Cutflow		Material Thickness	Arc Voltage	Torch-to-Work Distance	Cutting Speed	Initial Pierce Height		Pierce Delay Time			
Plasma gas	Shield gas	Plasma gas	Shield gas	Plasma gas	Shield gas					mm	Volts		mm	mm/m	mm
O ₂	Air	22	49	76	46	6	150	2.8	6500	8.5	300	0.3			
						8									
						10									
						12									
				80	49	80	49	15	155	3.6	3.6	3130	9.0	250	0.5
								20	159						0.6
								22	166						0.7
								25	171						0.8
				84	49	84	49	28	170	4.8	4.8	1445	9.5	200	0.9
								32	172			1135			1.0
								38	174			895			Edge start
								44	185			580			
								50	188			405			
								58	193			290			
								64	202			195			

English

Select Gases		Set Preflow		Set Cutflow		Material Thickness	Arc Voltage	Torch-to-Work Distance	Cutting Speed	Initial Pierce Height		Pierce Delay Time			
Plasma gas	Shield gas	Plasma gas	Shield gas	Plasma gas	Shield gas					in	Volts		in	ipm	in
O ₂	Air	22	49	76	46	1/4	150	0.11	245	0.33	300	0.3			
						5/16									
						3/8									
						1/2									
				80	49	80	49	5/8	155	0.14	0.14	115	0.35	250	0.5
								3/4	159			90			0.6
								7/8	166			75			0.7
								1	171			65			0.8
				84	49	84	49	1-1/8	170	0.19	0.19	55	0.38	200	0.9
								1-1/4	172			45			1.0
								1-1/2	174			35			Edge start
								1-3/4	185			22			
								2	188			15			
								2-1/4	193			12			
								2-1/2	202			8			

Marking

Select Gases		Set Preflow		Set Cutflow		Amperage	Torch-to-Work Distance		Marking Speed		Arc Voltage
Plasma gas	Shield gas	Plasma gas	Shield gas	Plasma gas	Shield gas		mm	in	mm/m	ipm	
N ₂	N ₂	10	10	10	10	18	2.5	0.10	6350	250	135
Ar	Air	30	20	30	20	24	3.0	0.12	2540	100	68

OPERATION

Mild steel bevel cutting (standard)

O₂ Plasma / Air Shield

260 A

Flow rates – lpm/scfh		
	O ₂	Air
Preflow	0 / 0	130 / 275
Cutflow	42 / 88	104 / 220

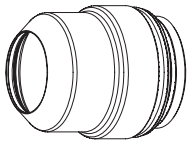

220637

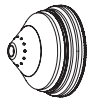

220741

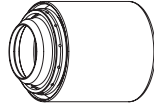

220740

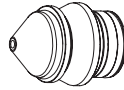

220542



220436

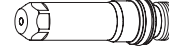

220541

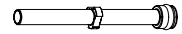

220571

Metric

Select Gases		Set Preflow		Set Cutflow		Minimum Clearance	Equivalent Material Thickness	Torch-to-Work Distance	Cutting Speed	Initial Pierce Height		Pierce Delay Time
Plasma gas	Shield gas	Plasma gas	Shield gas	Plasma gas	Shield gas	mm	mm	Range (mm)	mm/m	mm	Factor %	Seconds
O ₂	Air	22	49	76	46	2.0	6	2.8 – 7.6	6500	8.5	300	0.3
							8		5470			
							10		4440			
							12		3850			
							15		3130			
							20		2170			
				22	1930		3.6 – 7.6	9.0	250	0.7		
				25	1685							
				28	1445							
				32	1135							
				38*	895							
				44	580							
				50	405		4.8 – 7.6	9.5	200	1.0		
				58	290							
				64	195							
				Edge start								
Edge start												
Edge start												

English

Select Gases		Set Preflow		Set Cutflow		Minimum Clearance	Equivalent Material Thickness	Torch-to-Work Distance	Cutting Speed	Initial Pierce Height		Pierce Delay Time
Plasma gas	Shield gas	Plasma gas	Shield gas	Plasma gas	Shield gas	in	in	Range (in)	ipm	in	Factor %	Seconds
O ₂	Air	22	49	76	46	0.08	1/4	0.11 – 0.30	245	0.33	300	0.3
							5/16		215			
							3/8		180			
							1/2		145			
							5/8		115			
							3/4		90			
				7/8	75		0.14 – 0.30	0.35	250	0.7		
				1	65							
				1-1/8	55							
				1-1/4	45							
				1-1/2*	35							
				1-3/4	22							
				2	15		0.19 – 0.30	0.38	200	1.0		
				2-1/4	12							
				2-1/2	8							
				Edge start								
Edge start												
Edge start												

Marking

Select Gases		Set Preflow		Set Cutflow		Amperage	Torch-to-Work Distance		Marking Speed		Arc Voltage
						Amps	mm	in	mm/m	ipm	Volts
N ₂	N ₂	10	10	10	10	18	2.5	0.10	6350	250	135
Ar	Air	30	20	30	20	24	3.0	0.12	2540	100	68

* See the alternate, thick metal piercing, cut chart if you have a problem with excessive slag on the shield or problems with the torch misfiring.

**Mild steel bevel cutting (alternate)
thick metal piercing**

O₂ Plasma / Air Shield
260 A

Flow rates – lpm/scfh		
	O ₂	Air
Preflow	0 / 0	85 / 180
Cutflow	47 / 99	54 / 115

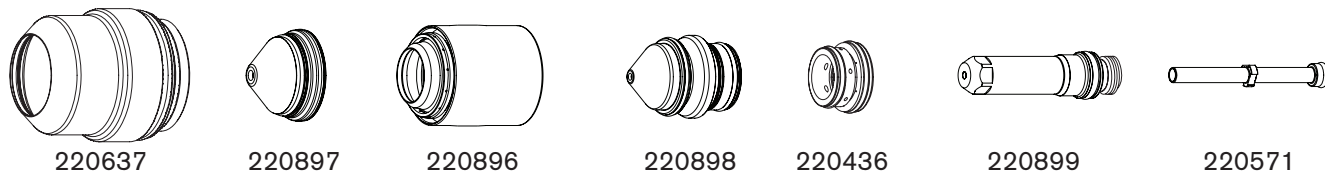

Metric

Select Gases		Set Preflow		Set Cutflow		Minimum Clearance	Equivalent Material Thickness	Torch-to-Work Distance	Cutting Speed	Initial Pierce Height		Pierce Delay Time	
Plasma gas	Shield gas	Plasma gas	Shield gas	Plasma gas	Shield gas	mm	mm	Range (mm)	mm/m	mm	Factor %	Seconds	
O ₂	Air	22	20	74	19	2.0	25	3.6 – 7.6	1685	9.0	250	0.8	
							28		1445				1.0
							32	4.8 – 7.6	1135	9.5	200	1.2	
							38*		895				3.0
							44		580				Edge start
							50	405					
							58	290					
64	195												

English

Select Gases		Set Preflow		Set Cutflow		Minimum Clearance	Equivalent Material Thickness	Torch-to-Work Distance	Cutting Speed	Initial Pierce Height		Pierce Delay Time	
Plasma gas	Shield gas	Plasma gas	Shield gas	Plasma gas	Shield gas	in	in	Range (in)	ipm	in	Factor %	Seconds	
O ₂	Air	22	20	74	19	0.08	1	0.14 – 0.30	65	0.35	250	0.8	
							1-1/8		55				1.0
							1-1/4	0.19 – 0.30	45	0.38	200	1.2	
							1-1/2*		35				3.0
							1-3/4		22				Edge start
							2	15					
							2-1/4	12					
2-1/2	8												

Marking

Select Gases		Set Preflow		Set Cutflow		Amperage	Torch-to-Work Distance		Marking Speed		Arc Voltage
Plasma gas	Shield gas	Plasma gas	Shield gas	Plasma gas	Shield gas	Amps	mm	in	mm/m	ipm	Volts
N ₂	N ₂	10	10	10	10	18	2.5	0.10	6350	250	122
Ar	Air	30	10	30	10	24	3.0	0.12	2540	100	62

The consumables on this page are designed for thick metal piercing. They are only recommended for use if you have a problem with excessive slag on the shield, or problems with the torch misfiring, when using the standard bevel consumables.

Using the thick metal piercing process may result in a 20% decrease in the life of the consumables.

* Suggestions for piercing 38 mm (1-1/2 in) mild steel:

1. Turn preflow on during IHS
2. Use stall force during IHS
3. Use pierce complete when piercing

OPERATION

Flow rates – lpm/scfh		
	O ₂	Air
Preflow	0 / 0	130 / 275
Cutflow	42 / 88	104 / 220

Mild steel underwater cutting

No more than 75 mm (3 in) below the surface of the water

O₂ Plasma / Air Shield

260 A

Note: Preflow must be on during IHS.

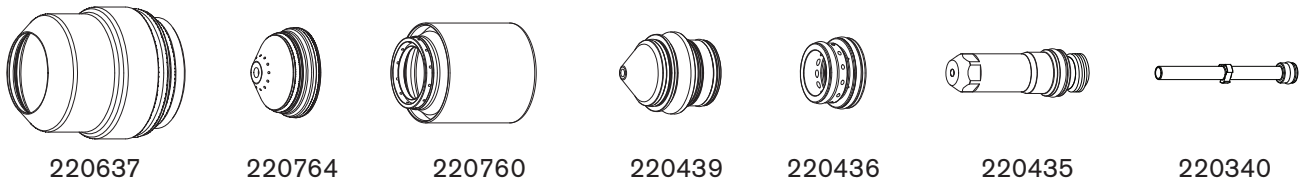

Metric

Select Gases		Set Preflow		Set Cutflow		Material Thickness	Arc Voltage	Torch-to-Work Distance	Cutting Speed	Initial Pierce Height		Pierce Delay Time		
Plasma gas	Shield gas	Plasma gas	Shield gas	Plasma gas	Shield gas					mm	Volts		mm	mm
O ₂	Air	22	49	76	49	8	150	2.8	4889	8.4	300	0.3		
						10			3997					
						12			3501					
				80	49	84	49	15	156	3.6	2830	9.0	250	0.5
								20	160		1958			0.6
								22	162		1750			0.7
								25	165		1527			0.8
				28	170	4.8	1311	9.6	200	0.9				

English

Select Gases		Set Preflow		Set Cutflow		Material Thickness	Arc Voltage	Torch-to-Work Distance	Cutting Speed	Initial Pierce Height		Pierce Delay Time		
Plasma gas	Shield gas	Plasma gas	Shield gas	Plasma gas	Shield gas					inches	Volts		inches	ipm
O ₂	Air	22	49	76	46	5/16	150	0.11	194	0.33	300	0.3		
						3/8			162					
						1/2			153				131	0.4
				80	49	84	49	5/8	157	0.14	104	0.35	250	0.5
								3/4	159		81			0.6
								7/8	162		68			0.7
								1	165		59			0.8
				1-1/8	171	0.19	50	0.38	200	0.9				

Mild steel
O₂ Plasma / Air Shield
400 A

Flow rates – lpm/scfh		
	O ₂	Air
Preflow	0 / 0	190 / 400
Cutflow	66 / 140	137 / 290

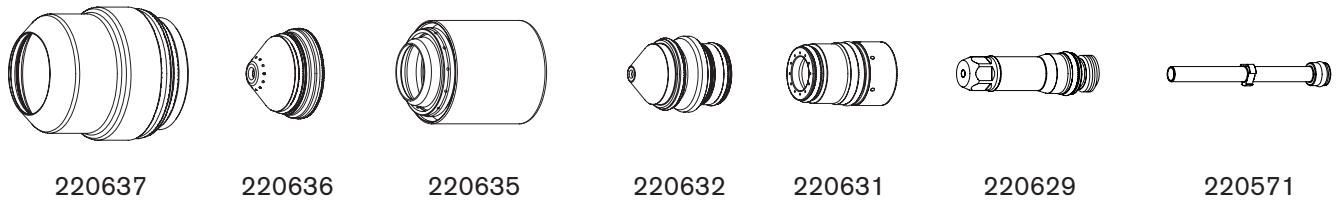

Metric

Select Gases		Set Preflow		Set Cutflow		Material Thickness	Arc Voltage	Torch-to-Work Distance	Cutting Speed	Initial Pierce Height		Pierce Delay Time						
Plasma gas	Shield gas	Plasma gas	Shield gas	Plasma gas	Shield gas					mm	Volts		mm	mm/m	mm	Factor %	Seconds	
O ₂	Air	24	50	60	50	12	139	3.6	4430	7.2	200	0.4						
						15	142		3950			0.5						
						20	146		2805			0.7						
												22	148	3.8	2540	7.6	0.8	
												25	150	4.0	2210	8.0	0.9	
												30	153	4.6	1790	9.2	1.1	
												40	158		1160	11.5	250	1.9
												50	167	5.3	795	19.1	360	5.2
												60	173	6.4	580	Edge start		
												70	183		380			
												80	197	7.9	180			

English

Select Gases		Set Preflow		Set Cutflow		Material Thickness	Arc Voltage	Torch-to-Work Distance	Cutting Speed	Initial Pierce Height		Pierce Delay Time						
Plasma gas	Shield gas	Plasma gas	Shield gas	Plasma gas	Shield gas					in	Volts		in	ipm	in	Factor %	Seconds	
O ₂	Air	24	50	60	50	1/2	140	0.14	170	0.28	200	0.4						
						5/8	143		150			0.5						
						3/4	145		115			0.6						
												7/8	148	0.15	100	0.30	0.8	
												1	151	0.16	85	0.32	0.9	
												1-1/4	153	0.18	65	0.36	1.2	
												1-1/2	157		48	0.45	250	1.6
												1-3/4	160		40		2.5	
												2	168	0.21	30	0.75	360	5.5
												2-1/4	171	0.25	25	Edge start		
												2-1/2	175		20			
						3	193	0.31	10									

Marking

Select Gases		Set Preflow		Set Cutflow		Amperage	Torch-to-Work Distance		Marking Speed		Arc Voltage
							mm	in	mm/m	ipm	
N ₂	N ₂	10	10	10	10	22	2.5	0.10	1270	50	123
Ar	Air	20	10	30	10	25	3.0	0.12	1270	50	55

OPERATION

Mild steel bevel cutting

O₂ Plasma / Air Shield

400 A

Flow rates – lpm/scfh		
	O ₂	Air
Preflow	0 / 0	190 / 400
Cutflow	66 / 140	137 / 290

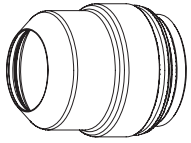

220637



220636

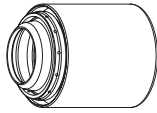

220635

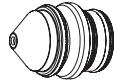

220632

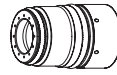

220631

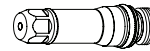

220629



220571

Note: Bevel angle range is 0° to 45°.

Metric

Select Gases		Set Preflow		Set Cutflow		Minimum Clearance	Equivalent Material Thickness	Torch-to-Work Distance	Cutting Speed	Initial Pierce Height		Pierce Delay Time
Plasma gas	Shield gas	Plasma gas	Shield gas	Plasma gas	Shield gas	mm	mm	Range (mm)	mm/m	mm	Factor %	Seconds
O ₂	Air	24	50	60	50	2.0	12	3.6 – 9.4	4430	7.2	200	0.4
							15		3950			0.5
							20		2805			0.7
							22	3.8 – 9.4	2540	7.6	0.8	
							25	4.0 – 9.4	2210	8.0	0.9	
							30	4.6 – 9.4	1790	9.2	1.1	
							40		1160	11.5	250	1.9
							50	5.3 – 9.4	795	19.1	360	5.2
							60	6.4 – 9.4	580	Edge start		
							70		380			
80	7.9 – 9.4	180										

English

Select Gases		Set Preflow		Set Cutflow		Minimum Clearance	Equivalent Material Thickness	Torch-to-Work Distance	Cutting Speed	Initial Pierce Height		Pierce Delay Time
Plasma gas	Shield gas	Plasma gas	Shield gas	Plasma gas	Shield gas	in	in	Range (in)	ipm	in	Factor %	Seconds
O ₂	Air	24	50	60	50	0.08	1/2	0.14 – 0.37	170	0.28	200	0.4
							5/8		150			0.5
							3/4		115			0.6
							7/8	0.15 – 0.37	100	0.30	0.8	
							1	0.16 – 0.37	85	0.32	0.9	
							1-1/4	0.18 – 0.37	65	0.36	1.2	
							1-1/2		48	0.45	250	1.6
							1-3/4	40	2.5			
							2	0.21 – 0.37	30	0.75	360	5.5
							2-1/4	0.25 – 0.37	25	Edge start		
2-1/2	20											
3	0.31 – 0.37	10										

Marking

Select Gases		Set Preflow		Set Cutflow		Amperage	Torch-to-Work Distance		Marking Speed		Arc Voltage
						Amps	mm	in	mm/m	ipm	Volts
N ₂	N ₂	10	10	10	10	22	2.5	0.10	1270	50	123
Ar	Air	20	10	30	10	25	3.0	0.12	1270	50	55

Flow rates – lpm/scfh		
	O ₂	Air
Preflow	0 / 0	190 / 400
Cutflow	66 / 140	137 / 290

Mild steel underwater cutting

No more than 75 mm (3 in) below the surface of the water

O₂ Plasma / Air Shield

400 A

Note: Preflow must be on during IHS.



Metric

Select Gases		Set Preflow		Set Cutflow		Material Thickness	Arc Voltage	Torch-to-Work Distance	Cutting Speed	Initial Pierce Height		Pierce Delay Time
Plasma gas	Shield gas	Plasma gas	Shield gas	Plasma gas	Shield gas					mm	Volts	
O ₂	Air	24	50	60	50	16	144	3.6	3398	7.2	200	0.5
						20	147		2535			0.7
						22	150		2311			7.6
						25	153	4.0	1997	8.0		0.9
						30	155	4.6	1624	9.2		1.1
						40	160		1039	11.5		250

English

Select Gases		Set Preflow		Set Cutflow		Material Thickness	Arc Voltage	Torch-to-Work Distance	Cutting Speed	Initial Pierce Height		Pierce Delay Time	
Plasma gas	Shield gas	Plasma gas	Shield gas	Plasma gas	Shield gas					inches	Volts		inches
O ₂	Air	24	50	60	50	5/8	144	0.14	135	0.28	200	0.5	
						3/4	146		104			0.6	
						7/8	150	0.15	90	0.30		0.8	
						1	154	0.16	77	0.32		0.9	
						1-1/4	156	0.18	59	0.36		1.2	
						1-1/2	159		43	0.45		250	1.6
						1-3/4	162		36			2.5	

OPERATION

Stainless steel N₂ Plasma / N₂ Shield 45 A

Flow rates – lpm/scfh	
N ₂	
Preflow	24 / 51
Cutflow	75 / 159

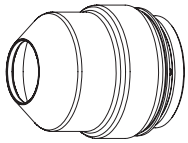

220747



220202

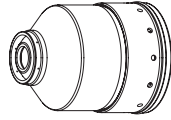

220755



220201



220180

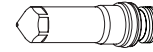

220308

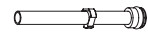

220340

Metric

Select Gases		Set Preflow		Set Cutflow		Material Thickness	Arc Voltage	Torch-to-Work Distance	Cutting Speed	Initial Pierce Height		Pierce Delay Time
Plasma gas	Shield gas	Plasma gas	Shield gas	Plasma gas	Shield gas					mm	Volts	
N ₂	N ₂	35	5	62	49	0.8	94	2.5	6380	3.8	150	0.0
						1			5880			0.1
						1.2			5380			0.2
						1.5	4630					
						2	3935					
						2.5	3270					
						3	2550					
						4	1580		0.3			

English

Select Gases		Set Preflow		Set Cutflow		Material Thickness	Arc Voltage	Torch-to-Work Distance	Cutting Speed	Initial Pierce Height		Pierce Delay Time
Plasma gas	Shield gas	Plasma gas	Shield gas	Plasma gas	Shield gas					in	Volts	
N ₂	N ₂	35	5	62	49	0.036	94	0.10	240	0.15	150	0.0
						0.048			210			0.1
						0.060	95		180			0.2
						0.075	97		160			
						0.105	101		120			
						0.135	103		75			

Marking

Select Gases		Set Preflow		Set Cutflow		Amperage	Torch-to-Work Distance		Marking Speed		Arc Voltage
Plasma gas	Shield gas	Plasma gas	Shield gas	Plasma gas	Shield gas		mm	in	mm/m	ipm	
N ₂	N ₂	10	10	10	10	15	2.5	0.10	6350	250	85
Ar	N ₂	90	10	90	10	12	2.5	0.10	2540	100	65

Note: This process produces a darker cut edge than the 45 A, F5/N₂ stainless steel process.

Stainless steel
F5 Plasma / N₂ Shield
45 A

Flow rates – lpm/scfh		
	F5	N ₂
Preflow	0 / 0	43 / 91
Cutflow	8 / 17	65 / 138

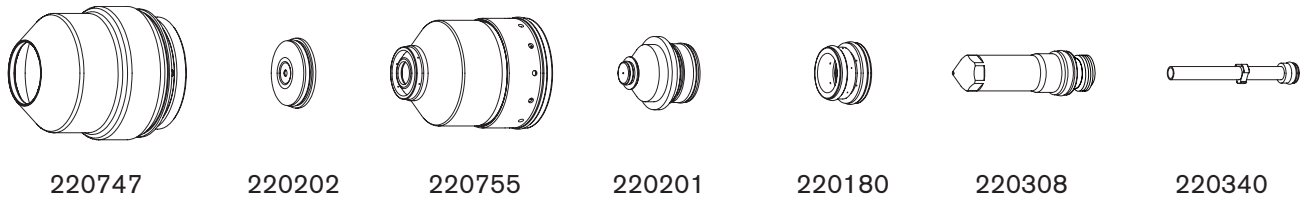

Metric

Select Gases		Set Preflow		Set Cutflow		Material Thickness	Arc Voltage	Torch-to-Work Distance	Cutting Speed	Initial Pierce Height		Pierce Delay Time
Plasma gas	Shield gas	Plasma gas	Shield gas	Plasma gas	Shield gas					mm	Volts	
F5	N ₂	35	18	62	49	0.8	99	2.5	6570	3.8	150	0.2
						1			5740			
						1.2			4905			
						1.5			3890			
						2			3175			
						2.5			2510			
						3			2010			
					4	1435						
					11	6	110	2.0	845		190	0.5

English

Select Gases		Set Preflow		Set Cutflow		Material Thickness	Arc Voltage	Torch-to-Work Distance	Cutting Speed	Initial Pierce Height		Pierce Delay Time
Plasma gas	Shield gas	Plasma gas	Shield gas	Plasma gas	Shield gas					in	Volts	
F5	N ₂	35	18	62	49	0.036	99	0.10	240	0.15	150	0.2
						0.048			190			
						0.060			150			
						0.075			130			
						0.105			90			
						0.135			65			
						3/16			45			
					1/4	30						
					11	3/16	108	0.08	45		190	0.4
						1/4	110		30			0.5

Marking

Select Gases		Set Preflow		Set Cutflow		Amperage	Torch-to-Work Distance		Marking Speed		Arc Voltage
							mm	in	mm/m	ipm	
N ₂	N ₂	10	10	10	10	15	2.5	0.10	6350	250	85
Ar	N ₂	90	10	90	10	12	2.5	0.10	2540	100	65

Note: This process produces a shinier cut edge than the 45 A, N₂/N₂ stainless steel process.

OPERATION

Stainless steel HDi

F5 Plasma / N₂ Shield

60 A

Flow rates – lpm/scfh		
	F5	N ₂
Preflow	0 / 0	76 / 160
Cutflow	20 / 42	58 / 122

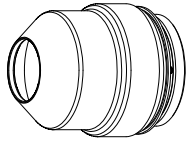

220747



220815

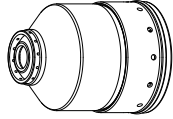

220814



220847



220180

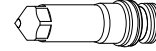

220339

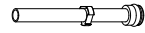

220340

Metric

Select Gases		Set Preflow		Set Cutflow		Material Thickness	Arc Voltage	Torch-to-Work Distance	Cutting Speed	Initial Pierce Height		Pierce Delay Time
Plasma gas	Shield gas	Plasma gas	Shield gas	Plasma gas	Shield gas					mm	Volts	
F5	N ₂	70	40	90	35	3	114	2.0	2770	4.0	200	0.3
						4	117		2250			
						5	118		1955			
						6	120		1635			
					45	6	120					0.5

English

Select Gases		Set Preflow		Set Cutflow		Material Thickness	Arc Voltage	Torch-to-Work Distance	Cutting Speed	Initial Pierce Height		Pierce Delay Time
Plasma gas	Shield gas	Plasma gas	Shield gas	Plasma gas	Shield gas					in	Volts	
F5	N ₂	70	40	90	35	0.105	113	0.08	120	0.16	200	0.3
						0.135	116		95			
						3/16	118		80			
						1/4	120		60			
					45	1/4	120					0.5

Marking

Select Gases		Set Preflow		Set Cutflow		Amperage	Torch-to-Work Distance		Marking Speed		Arc Voltage
							mm	in	mm/m	ipm	
N ₂	N ₂	10	10	10	10	15	2.5	0.1	6350	250	95
Ar	N ₂	90	10	90	10	8	2.5	0.1	2540	100	82

Stainless steel
F5 Plasma / N₂ Shield
80 A

Flow rates – lpm/scfh		
	F5	N ₂
Preflow	0 / 0	67 / 142
Cutflow	31 / 65	87 / 185

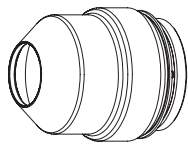

220747



220338

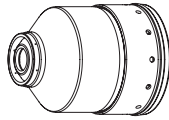

220755



220337



220179

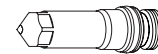

220339



220340

Metric

Select Gases		Set Preflow		Set Cutflow		Material Thickness	Arc Voltage	Torch-to-Work Distance	Cutting Speed	Initial Pierce Height		Pierce Delay Time
Plasma gas	Shield gas	Plasma gas	Shield gas	Plasma gas	Shield gas					mm	Volts	
F5	N ₂	33	23	65	60	4	108	3.0	2180	4.5	150	0.2
						5	110	2.7	1700	4.1		0.3
						6	112	2.5	1225	3.8		0.4
						8	116	3.0	895	4.5		0.5
						10	120		560			

English

Select Gases		Set Preflow		Set Cutflow		Material Thickness	Arc Voltage	Torch-to-Work Distance	Cutting Speed	Initial Pierce Height		Pierce Delay Time
Plasma gas	Shield gas	Plasma gas	Shield gas	Plasma gas	Shield gas					in	Volts	
F5	N ₂	33	23	65	60	0.135	108	0.12	105	0.18	150	0.2
						3/16	110	0.11	60	0.17		0.3
						1/4	112	0.10	45	0.15		0.4
						5/16	116	0.12	35	0.18		0.5
									25			

Marking

Select Gases		Set Preflow		Set Cutflow		Amperage	Torch-to-Work Distance		Marking Speed		Arc Voltage
							mm	in	mm/m	ipm	
N ₂	N ₂	10	10	10	10	15	2.5	0.10	6350	250	95
Ar	N ₂	50	10	50	10	12	3.0	0.12	2540	100	60

OPERATION

Stainless steel N₂ Plasma / N₂ Shield 130 A

Flow rates – lpm/scfh	
N ₂	
Preflow	97 / 205
Cutflow	79 / 168

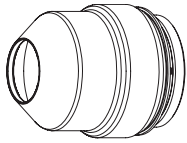

220747



220198

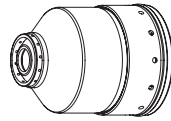

220756



220197



220179

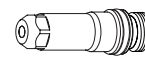

220307

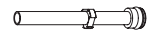

220340

Metric

Select Gases		Set Preflow		Set Cutflow		Material Thickness	Arc Voltage	Torch-to-Work Distance	Cutting Speed	Initial Pierce Height		Pierce Delay Time					
Plasma gas	Shield gas	Plasma gas	Shield gas	Plasma gas	Shield gas					mm	Volts		mm	mm	Factor %	Seconds	
N ₂	N ₂	19	51	75	23	6	153	3.0	1960	6.0	200	0.3					
						8	155		1630			0.4					
						10	156		1300			0.5					
												12	162	3.5	900	7.0	0.8
												15	167	3.8	670	Edge start	
												20	176	4.3	305	Edge start	

English

Select Gases		Set Preflow		Set Cutflow		Material Thickness	Arc Voltage	Torch-to-Work Distance	Cutting Speed	Initial Pierce Height		Pierce Delay Time					
Plasma gas	Shield gas	Plasma gas	Shield gas	Plasma gas	Shield gas					in	Volts		in	ipm	in	Factor %	Seconds
N ₂	N ₂	19	51	75	23	1/4	153	0.12	75	0.24	200	0.3					
						5/16	155		64			0.4					
						3/8	156		55			0.5					
												1/2	162	0.14	30	0.28	0.8
												5/8	167	0.15	25	Edge start	
												3/4	176	0.17	15	Edge start	

Marking

Select Gases		Set Preflow		Set Cutflow		Amperage	Torch-to-Work Distance		Marking Speed		Arc Voltage
Plasma gas	Shield gas	Plasma gas	Shield gas	Plasma gas	Shield gas		mm	in	mm/m	ipm	
N ₂	N ₂	10	10	10	10	18	2.5	0.10	6350	250	140
Ar	N ₂	50	10	50	10	15	3.0	0.12	2540	100	75

Note: This process produces a rougher, darker cut edge with more dross, and the cut edges are closer to perpendicular than the 130 A, H35/N₂ process.

Stainless steel
H35 Plasma / N₂ Shield
130 A

Flow rates – lpm/scfh		
	H35	N ₂
Preflow	0 / 0	76 / 160
Cutflow	26 / 54	68 / 144



Metric

Select Gases		Set Preflow		Set Cutflow		Material Thickness	Arc Voltage	Torch-to-Work Distance	Cutting Speed	Initial Pierce Height		Pierce Delay Time	
Plasma gas	Shield gas	Plasma gas	Shield gas	Plasma gas	Shield	mm	Volts	mm	mm/m	mm	Factor %	Seconds	
H35	N ₂	19	32	75	49	8	150	4.5	1140	7.7	170	0.3	
						10	154		980				
					37	12	158		820				0.5
						15	162		580				0.8
					24	20	165		360				1.3
					16	25	172		260			Edge start	

English

Select Gases		Set Preflow		Set Cutflow		Material Thickness	Arc Voltage	Torch-to-Work Distance	Cutting Speed	Initial Pierce Height		Pierce Delay Time	
Plasma gas	Shield gas	Plasma gas	Shield gas	Plasma gas	Shield gas	in	Volts	in	ipm	in	Factor %	Seconds	
H35	N ₂	19	32	75	49	5/16	150	0.18	45	0.31	170	0.3	
						3/8	154		40				
					37	1/2	158		30				0.5
						5/8	162		20				0.8
					24	3/4	165		15				1.3
					16	1	172		10			Edge start	

Marking

Select Gases		Set Preflow		Set Cutflow		Amperage	Torch-to-Work Distance		Marking Speed		Arc Voltage
						Amps	mm	in	mm/m	ipm	Volts
N ₂	N ₂	10	10	10	10	18	2.5	0.10	6350	250	130
Ar	N ₂	50	10	50	10	15	3.0	0.12	2540	100	75

Note: This process produces a smoother, shinier cut edge with less dross, and the cut edges are less perpendicular than the 130 A, N₂/N₂ process.

OPERATION

Stainless steel H35 and N₂ Plasma / N₂ Shield 130 A

Flow rates – lpm/scfh		
	H35	N ₂
Preflow	0 / 0	97 / 205
Cutflow	13 / 28	71 / 150

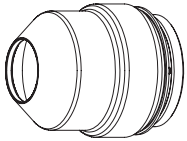

220747



220198

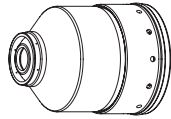

220755



220197



220179



220307

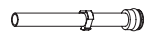

220340

Metric

Select Gases		Set Preflow		Set Cutflow				Material Thickness	Arc Voltage	Torch-to-Work Distance	Cutting Speed	Initial Pierce Height		Pierce Delay Time
Plasma gas	Shield gas	Plasma gas	Shield gas	Plasma gas	Shield gas	Mix Gas 1	Mix Gas 2	mm	Volts	mm	mm/m	mm	Factor %	Seconds
H35	N ₂	19	51	75	38	32	18	6	150	3.0	1835	6.0	200	0.3
					8			152	1515					
					10			153	1195					
					12			160	3.5	875	7.0	0.5		
					15			168	3.8	670	7.6	0.8		
20	176	4.3	305	7.7	180	1.3								

English

Select Gases		Set Preflow		Set Cutflow				Material Thickness	Arc Voltage	Torch-to-Work Distance	Cutting Speed	Initial Pierce Height		Pierce Delay Time
Plasma gas	Shield gas	Plasma gas	Shield gas	Plasma gas	Shield gas	Mix Gas 1	Mix Gas 2	in	Volts	in	ipm	in	Factor %	Seconds
H35	N ₂	19	51	75	38	32	18	1/4	150	0.12	70	0.24	200	0.3
					5/16			152	60					
					3/8			153	50					
					1/2			160	0.14	30	0.28	0.5		
					5/8			168	0.15	25	0.30	0.8		
3/4	176	0.17	15	0.31	180	1.3								

Marking

Select Gases		Set Preflow		Set Cutflow		Amperage	Torch-to-Work Distance		Marking Speed		Arc Voltage
						Amps	mm	in	mm/m	ipm	Volts
N ₂	N ₂	10	10	10	10	18	2.5	0.10	6350	250	130
Ar	N ₂	50	10	50	10	15	3.0	0.12	2540	100	75

Note: This process produces a smoother, shinier cut edge with less dross, and the cut edges are less perpendicular than the 130 A, N₂/N₂ process. Edge color is more silver than the H35/N₂ process.

Stainless steel bevel cutting

N₂ Plasma / N₂ Shield
130 A

Flow rates – lpm/scfh	
N ₂	
Preflow	97 / 205
Cutflow	125 / 260

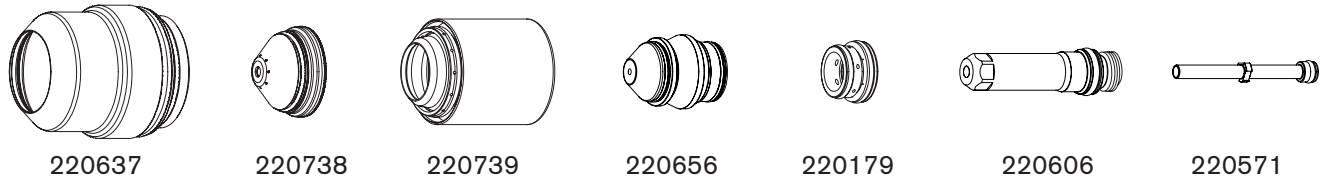

Note: Bevel angle range is 0° to 45°.

Metric

Select Gases		Set Preflow		Set Cutflow		Minimum Clearance	Equivalent Material Thickness	Torch-to-Work Distance	Cutting Speed	Initial Pierce Height		Pierce Delay Time							
Plasma gas	Shield gas	Plasma gas	Shield gas	Plasma gas	Shield gas	mm	mm	Range (mm)	mm/m	mm	Factor %	Seconds							
N ₂	N ₂	19	51	75	63	2.0	6	3.0 – 10.0	1960	6.0	200	0.3							
							8		1630			0.4							
							10		1300			0.5							
														12	3.5 – 10.0	900	7.0	Edge start	0.8
													15	3.8 – 10.0	670				
													20	4.3 – 10.0	305				

English

Select Gases		Set Preflow		Set Cutflow		Minimum Clearance	Equivalent Material Thickness	Torch-to-Work Distance	Cutting Speed	Initial Pierce Height		Pierce Delay Time							
Plasma gas	Shield gas	Plasma gas	Shield gas	Plasma gas	Shield gas	in	in	Range (in)	ipm	in	Factor %	Seconds							
N ₂	N ₂	19	51	75	63	0.08	1/4	0.12 – 0.40	75	0.24	200	0.3							
							5/16		64			0.4							
							3/8		55			0.5							
														1/2	0.14 – 0.40	30	0.28	Edge start	0.8
													5/8	0.15 – 0.40	25				
													3/4	0.17 – 0.40	15				

Marking

Select Gases		Set Preflow		Set Cutflow		Amperage	Torch-to-Work Distance		Marking Speed		Arc Voltage
						Amps	mm	in	mm/m	ipm	Volts
N ₂	N ₂	10	10	10	10	18	2.5	0.10	6350	250	140
Ar	N ₂	50	10	50	10	15	3.0	0.12	2540	100	75

OPERATION

Stainless steel bevel cutting

H35 Plasma / N₂ Shield
130 A

Flow rates – lpm/scfh		
	H35	N ₂
Preflow	0 / 0	90 / 190
Cutflow	26 / 54	114 / 240

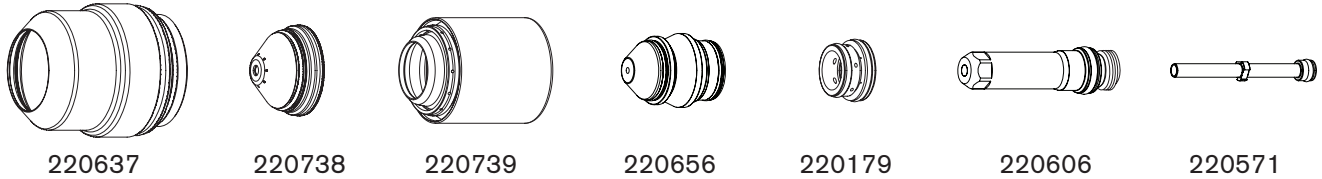

Note: Bevel angle range is 0° to 45°.

Metric

Select Gases		Set Preflow		Set Cutflow		Minimum Clearance	Equivalent Material Thickness	Torch-to-Work Distance	Cutting Speed	Initial Pierce Height		Pierce Delay Time
Plasma gas	Shield gas	Plasma gas	Shield gas	Plasma gas	Shield gas	mm	mm	Range (mm)	mm/m	mm	Factor %	Seconds
H35	N ₂	19	32	75	63	2.0	8	4.5 – 10.0	1140	7.7	170	0.3
							10		980			
							12		820			
							15		580			
							20		360			
							25		260			Edge start

English

Select Gases		Set Preflow		Set Cutflow		Minimum Clearance	Equivalent Material Thickness	Torch-to-Work Distance	Cutting Speed	Initial Pierce Height		Pierce Delay Time
Plasma gas	Shield gas	Plasma gas	Shield gas	Plasma gas	Shield gas	in	in	Range (in)	ipm	in	Factor %	Seconds
H35	N ₂	19	32	75	63	0.08	5/16	0.18 – 0.40	45	0.31	170	0.3
							3/8		40			
							1/2		30			
							5/8		20			
							3/4		15			
							1		10			Edge start

Marking

Select Gases		Set Preflow		Set Cutflow		Amperage	Torch-to-Work Distance		Marking Speed		Arc Voltage
						Amps	mm	in	mm/m	ipm	Volts
N ₂	N ₂	10	10	10	10	18	2.5	0.10	6350	250	130
Ar	N ₂	50	10	50	10	15	3.0	0.12	2540	100	75

Stainless steel bevel cutting

H35 and N₂ Plasma / N₂ Shield
130 A

Flow rates – lpm/scfh		
	H35	N ₂
Preflow	0 / 0	97 / 205
Cutflow	13 / 28	120 / 250



Note: Bevel angle range is 0° to 45°.

Metric

Select Gases		Set Preflow		Set Cutflow				Minimum Clearance	Equivalent Material Thickness	Torch-to-Work Distance	Cutting Speed	Initial Pierce Height		Pierce Delay Time									
Plasma gas	Shield gas	Plasma gas	Shield gas	Plasma gas	Shield gas	Mix Gas 1	Mix Gas 2	mm	mm	Range (mm)	mm/m	mm	Factor %	Seconds									
H35	N ₂	19	51	75	80	32	18	2.0	6	3.0 – 10.0	1835	6.0	200	0.3									
									8		1515												
									10		1195												
																		12	3.5 – 10.0	875	7.0		0.5
																		15	3.8 – 10.0	670	7.6		0.8
																		20	3.0 – 10.0	305	7.7	180	1.3

English

Select Gases		Set Preflow		Set Cutflow				Minimum Clearance	Equivalent Material Thickness	Torch-to-Work Distance	Cutting Speed	Initial Pierce Height		Pierce Delay Time									
Plasma gas	Shield gas	Plasma gas	Shield gas	Plasma gas	Shield gas	Mix Gas 1	Mix Gas 2	in	in	Range (in)	ipm	in	Factor %	Seconds									
H35	N ₂	19	51	75	80	32	18	0.080	1/4	0.12 – 0.40	70	0.24	200	0.3									
									5/16		60												
									3/8		50												
																		1/2	0.14 – 0.40	30	0.28		0.5
																		5/8	0.15 – 0.40	25	0.30		0.8
																		3/4	0.17 – 0.40	15	0.31	180	1.3

Marking

Select Gases		Set Preflow		Set Cutflow		Amperage	Torch-to-Work Distance		Marking Speed		Arc Voltage
						Amps	mm	in	mm/m	ipm	Volts
N ₂	N ₂	10	10	10	10	18	2.5	0.10	6350	250	130
Ar	N ₂	50	10	50	10	15	3.0	0.12	2540	100	75

OPERATION

Stainless steel N₂ Plasma / N₂ Shield 200 A

Flow rates – lpm/scfh	
N ₂	
Preflow	111 / 235
Cutflow	137 / 290

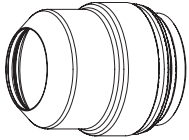

220637



220762

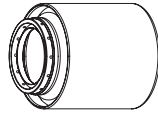

220758



220343



220342

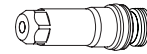

220307



220340

Metric

Select Gases		Set Preflow		Set Cutflow		Material Thickness	Arc Voltage	Torch-to-Work Distance	Cutting Speed	Initial Pierce Height		Pierce Delay Time
Plasma gas	Shield gas	Plasma gas	Shield gas	Plasma gas	Shield gas					mm	Volts	
N ₂	N ₂	17	42	84	42	8	159	3.8	3000	7.6	200	0.4
						10	160		2700			0.5
						12	161		2400			0.6
						15	163		1800			0.8
						20	167		1000			1.0

English

Select Gases		Set Preflow		Set Cutflow		Material Thickness	Arc Voltage	Torch-to-Work Distance	Cutting Speed	Initial Pierce Height		Pierce Delay Time
Plasma gas	Shield gas	Plasma gas	Shield gas	Plasma gas	Shield gas					in	Volts	
N ₂	N ₂	17	42	84	42	5/16	159	0.15	118	0.3	200	0.4
						3/8	160		110			0.5
						1/2	161		90			0.6
						5/8	163		65			0.8
						3/4	167		45			1.0

Marking

Select Gases		Set Preflow		Set Cutflow		Amperage	Torch-to-Work Distance		Marking Speed		Arc Voltage
Plasma gas	Shield gas	Plasma gas	Shield gas	Plasma gas	Shield gas		Amps	mm	in	mm/m	
N ₂	N ₂	10	10	10	10	18	2.5	0.10	6350	250	140
Ar	N ₂	30	10	30	10	20	3.0	0.12	2540	100	66

Stainless steel
H35 Plasma / N₂ Shield
200 A

Flow rates – lpm/scfh		
	H35	N ₂
Preflow	0 / 0	116 / 245
Cutflow	30 / 63	104 / 220

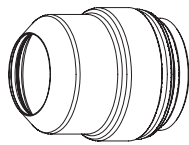

220637



220762

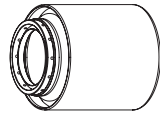

220758



220343



220342

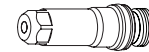

220307

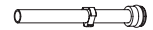

220340

Metric

Select Gases		Set Preflow		Set Cutflow		Material Thickness	Arc Voltage	Torch-to-Work Distance	Cutting Speed	Initial Pierce Height		Pierce Delay Time
Plasma gas	Shield gas	Plasma gas	Shield gas	Plasma gas	Shield gas					mm	Volts	
H35	N ₂	17	43	88	52	8	175	9.0	1790	9.0	100	0.4
						10						1620
						12	170	7.5	1450	0.6		
						15	173		1200	0.7		
						20	177		820	0.8		

English

Select Gases		Set Preflow		Set Cutflow		Material Thickness	Arc Voltage	Torch-to-Work Distance	Cutting Speed	Initial Pierce Height		Pierce Delay Time
Plasma gas	Shield gas	Plasma gas	Shield gas	Plasma gas	Shield gas					in	Volts	
H35	N ₂	17	43	88	52	5/16	175	0.35	70	0.35	100	0.4
						3/8						65
						1/2	170	0.30	55	0.6		
						5/8	173		45	0.7		
						3/4	177		35	0.8		

Marking

Select Gases		Set Preflow		Set Cutflow		Amperage	Torch-to-Work Distance		Marking Speed		Arc Voltage
Plasma gas	Shield gas	Plasma gas	Shield gas	Plasma gas	Shield gas		Amps	mm	in	mm/m	
N ₂	N ₂	10	10	10	10	18	2.5	0.10	6350	250	140
Ar	N ₂	30	10	30	10	20	3.0	0.12	2540	100	66

OPERATION

Stainless steel H35 and N₂ Plasma / N₂ Shield 200 A

Flow rates – lpm/scfh		
	H35	N ₂
Preflow	0 / 0	116 / 245
Cutflow	11 / 24	118 / 250

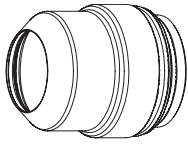

220637



220762

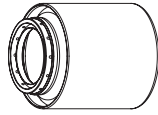

220758



220343



220342

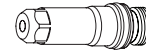

220307



220340

Metric

Select Gases		Set Preflow		Set Cutflow				Material Thickness	Arc Voltage	Torch-to-Work Distance	Cutting Speed	Initial Pierce Height		Pierce Delay Time
Plasma gas	Shield gas	Plasma gas	Shield gas	Plasma gas	Shield gas	Mix Gas 1	Mix Gas 2					mm	Volts	
H35	N ₂	17	41	87	41	42	20	8	160	4.0	2000	8.0	200	0.4
								10	161		1900			0.5
								12	162		1800			0.6
								15	167	4.6	1600	7.0	150	0.8
								20	171	5.1	1000	7.5		1.0

English

Select Gases		Set Preflow		Set Cutflow				Material Thickness	Arc Voltage	Torch-to-Work Distance	Cutting Speed	Initial Pierce Height		Pierce Delay Time
Plasma gas	Shield gas	Plasma gas	Shield gas	Plasma gas	Shield gas	Mix Gas 1	Mix Gas 2					in	Volts	
H35	N ₂	17	41	87	41	42	20	5/16	160	0.16	79	0.320	200	0.4
								3/8	161		75			0.5
								1/2	162		70			0.6
								5/8	167	0.18	60	0.270	150	0.8
								3/4	171	0.20	45	0.300		1.0

Marking

Select Gases		Set Preflow		Set Cutflow		Amperage	Torch-to-Work Distance		Marking Speed		Arc Voltage
							mm	in	mm/m	ipm	
N ₂	N ₂	10	10	10	10	18	2.5	0.10	6350	250	140
Ar	N ₂	30	10	30	10	20	3.0	0.12	2540	100	66

Stainless steel
N₂ Plasma / Air Shield
260 A

Flow rates – lpm/scfh		
	N ₂	Air
Preflow	127 / 270	0 / 0
Cutflow	54 / 114	116 / 245

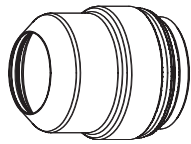

220637



220763

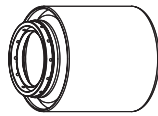

220758



220406



220405

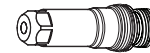

220307

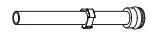

220340

Metric

Select Gases		Set Preflow		Set Cutflow		Material Thickness	Arc Voltage	Torch-to-Work Distance	Cutting Speed	Initial Pierce Height		Pierce Delay Time
Plasma gas	Shield gas	Plasma gas	Shield gas	Plasma gas	Shield gas					mm	Volts	
N ₂	Air	12	47	79	56	6	160	3.8	6375	7.5	200	0.3
						8	158		4910			
						10	157		3440			
						12	161		2960			
						15	163		2520			
						20	164		1590			
						25	168		1300			
						32	171		875			
						38	179		515			
						44	190		365			
						50	195		180			Edge start

English

Select Gases		Set Preflow		Set Cutflow		Material Thickness	Arc Voltage	Torch-to-Work Distance	Cutting Speed	Initial Pierce Height		Pierce Delay Time
Plasma gas	Shield gas	Plasma gas	Shield gas	Plasma gas	Shield gas					in	Volts	
N ₂	Air	12	47	79	56	1/4	160	0.15	240	0.3	200	0.3
						5/16	158		193			
						3/8	157		140			
						1/2	161		110			
						5/8	163		95			
						3/4	164		70			
						1	168		50			
						1-1/4	171		35			
						1-1/2	179		20			
						1-3/4	190		14			
						2	200		6			Edge start

Marking

Select Gases		Set Preflow		Set Cutflow		Amperage	Torch-to-Work Distance		Marking Speed		Arc Voltage
Plasma gas	Shield gas	Plasma gas	Shield gas	Plasma gas	Shield gas		mm	in	mm/m	ipm	
N ₂	N ₂	10	10	10	10	18	2.5	0.10	6350	250	120
Ar	N ₂	30	10	30	10	20	3.0	0.12	2540	100	63

OPERATION

Stainless steel H35 Plasma / N₂ Shield 260 A

Flow rates – lpm/scfh		
	H35	N ₂
Preflow	0 / 0	127 / 270
Cutflow	40 / 84	122 / 260

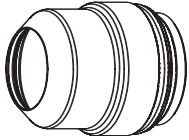

220637



220763

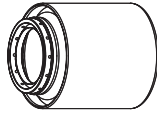

220758



220406



220405

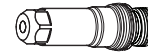

220307



220340

Metric

Select Gases		Set Preflow		Set Cutflow		Material Thickness	Arc Voltage	Torch-to-Work Distance	Cutting Speed	Initial Pierce Height		Pierce Delay Time
Plasma gas	Shield gas	Plasma gas	Shield gas	Plasma gas	Shield gas					mm	Volts	
H35	N ₂	12	49	85	60	8	188	11.0	2030	11.0	100	0.3
						10						
						12	173	9.0	1710	9.0	120	0.4
						15	171	7.5	1465			
						20	175		1085	0.6		
						25	180	785	0.7			
						32	185	630	1.0			
						38	186	510	Edge start			
						44	189	390				
						50	200	270				

English

Select Gases		Set Preflow		Set Cutflow		Material Thickness	Arc Voltage	Torch-to-Work Distance	Cutting Speed	Initial Pierce Height		Pierce Delay Time	
Plasma gas	Shield gas	Plasma gas	Shield gas	Plasma gas	Shield gas					in	Volts		in
H35	N ₂	12	49	85	60	5/16	188	0.45	80	0.45	100	0.3	
						3/8							75
						1/2	173	0.35	65	0.35	0.36	120	0.4
						5/8	171	0.30	55	0.5			
						3/4	175		45	0.6			
						1	180	30	0.7				
						1-1/4	185	25	1.0				
						1-1/2	186	20	Edge start				
						1-3/4	189	15					
						2	200	10					

Marking

Select Gases		Set Preflow		Set Cutflow		Amperage	Torch-to-Work Distance		Marking Speed		Arc Voltage
Plasma gas	Shield gas	Plasma gas	Shield gas	Plasma gas	Shield gas		Amps	mm	in	mm/m	
N ₂	N ₂	10	10	10	10	18	2.5	0.10	6350	250	120
Ar	N ₂	30	10	30	10	20	3.0	0.12	2540	100	63

Stainless steel

H35 and N₂ Plasma / N₂ Shield
260 A

Flow rates - lpm/scfh		
	H35	N ₂
Preflow	0 / 0	132 / 280
Cutflow	13 / 27	163 / 345

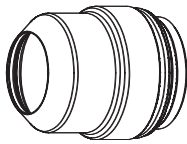

220637



220763

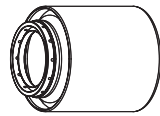

220758



220406



220405

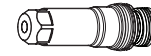

220307

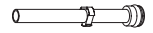

220340

Metric

Select Gases		Set Preflow		Set Cutflow				Material Thickness	Arc Voltage	Torch-to-Work Distance	Cutting Speed	Initial Pierce Height		Pierce Delay Time
Plasma gas	Shield gas	Plasma gas	Shield gas	Plasma gas	Shield gas	Mix Gas 1	Mix Gas 2	mm	Volts	mm	mm/m	mm	Factor %	Seconds
H35	N ₂	12	49	87	60	60	21	6	170	4.0	3980	8.0	200	0.3
								8	173		3085			
								10	175		2190			
								12	176		1790			
								15	177		1650			
								20	179		1320			
								25	182		920			
						40	26	32	186		755			Edge start
								38	189		510			
								44	195		390			
								50	202		270			

English

Select Gases		Set Preflow		Set Cutflow				Material Thickness	Arc Voltage	Torch-to-Work Distance	Cutting Speed	Initial Pierce Height		Pierce Delay Time
Plasma gas	Shield gas	Plasma gas	Shield gas	Plasma gas	Shield gas	Mix Gas 1	Mix Gas 2	in	Volts	in	ipm	in	Factor %	Seconds
H35	N ₂	12	49	87	60	60	21	1/4	170	0.16	150	0.32	200	0.3
								5/16	173		121			
								3/8	175		90			
								1/2	176		65			
								5/8	177		55			
								3/4	179		35			
								1	182		30			
						40	26	1-1/4	186		Edge start			
								1-1/2	189					
								1-3/4	187					
								2	202					

Marking

Select Gases		Set Preflow		Set Cutflow		Amperage	Torch-to-Work Distance		Marking Speed		Arc Voltage
						Amps	mm	in	mm/m	ipm	Volts
N ₂	N ₂	10	10	10	10	18	2.5	0.10	6350	250	120
Ar	N ₂	30	10	30	10	20	3.0	0.12	2540	100	63

OPERATION

Stainless steel bevel cutting

H35 Plasma / N₂ Shield
260 A

Flow rates – lpm/scfh		
	H35	N ₂
Preflow	0 / 0	127 / 270
Cutflow	40 / 84	122 / 260

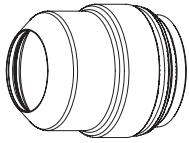

220637



220738

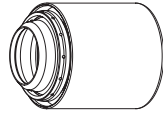

220739

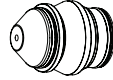

220607



220405

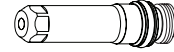

220606

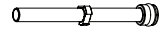

220571

Note: Bevel angle range is 0° to 45°.

Metric

Select Gases		Set Preflow		Set Cutflow		Minimum Clearance	Equivalent Material Thickness	Torch-to-Work Distance	Cutting Speed	Initial Pierce Height		Pierce Delay Time
Plasma gas	Shield gas	Plasma gas	Shield gas	Plasma gas	Shield gas	mm	mm	Range (mm)	mm/m	mm	Factor %	Seconds
H35	N ₂	12	49	85	60	2.0	8	11.0	2030	11.0	100	0.3
							10		1870			
							12	9.0 – 10.0	1710	9.0	120	0.4
							15		1465			
							20	7.5 – 10.0	1085	7.5 – 10.0	120	0.6
							25		785			
							32	7.5 – 10.0	630	7.5 – 10.0	120	0.7
							38		510			
							44	390	7.5 – 10.0	7.5 – 10.0	120	1.0
							50	270				
Edge start												

English

Select Gases		Set Preflow		Set Cutflow		Minimum Clearance	Equivalent Material Thickness	Torch-to-Work Distance	Cutting Speed	Initial Pierce Height		Pierce Delay Time
Plasma gas	Shield gas	Plasma gas	Shield gas	Plasma gas	Shield gas	in	in	Range (in)	ipm	in	Factor %	Seconds
H35	N ₂	12	49	85	60	0.08	5/16	0.45 – 0.40	80	0.45	100	0.3
							3/8		75			
							1/2	0.35 – 0.40	65	0.35	120	0.4
							5/8		55			
							3/4	0.30 – 0.40	45	0.36	120	0.6
							1		30			
							1-1/4	0.30 – 0.40	25	0.36	120	0.7
							1-1/2		20			
							1-3/4	0.30 – 0.40	15	0.36	120	1.0
							2		10			
Edge start												

Marking

Select Gases		Set Preflow		Set Cutflow		Amperage	Torch-to-Work Distance		Marking Speed		Arc Voltage
						Amps	mm	in	mm/m	ipm	Volts
N ₂	N ₂	10	10	10	10	18	2.5	0.10	6350	250	120
Ar	N ₂	30	10	30	10	20	3.0	0.12	2540	100	63

Stainless steel bevel cutting

N₂ Plasma / Air Shield

260 A

Flow rates – lpm/scfh		
	N ₂	Air
Preflow	127 / 270	0 / 0
Cutflow	54 / 114	116 / 245

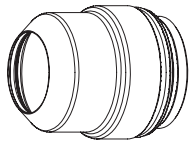

220637



220738

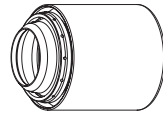

220739

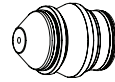

220607



220405

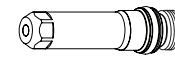

220606

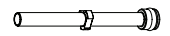

220571

Note: Bevel angle range is 0° to 45°.

Metric

Select Gases		Set Preflow		Set Cutflow		Minimum Clearance	Equivalent Material Thickness	Torch-to-Work Distance	Cutting Speed	Initial Pierce Height		Pierce Delay Time
Plasma gas	Shield gas	Plasma gas	Shield gas	Plasma gas	Shield gas	mm	mm	Range (mm)	mm/m	mm	Factor %	Seconds
N ₂	Air	12	47	79	56	2.0	6	3.8 – 10.0	6375	7.5	200	0.3
							8		4910			
							10		3440			
							12		2960			
							15		2520			
							20		1590			
							25		1300			
							32		875			
							38		515			
							44		365			
							50		180			

English

Select Gases		Set Preflow		Set Cutflow		Minimum Clearance	Equivalent Material Thickness	Torch-to-Work Distance	Cutting Speed	Initial Pierce Height		Pierce Delay Time
Plasma gas	Shield gas	Plasma gas	Shield gas	Plasma gas	Shield gas	in	in	Range (in)	ipm	in	Factor %	Seconds
N ₂	Air	12	47	79	56	0.08	1/4	0.15 – 0.40	240	0.3	200	0.3
							5/16		193			
							3/8		140			
							1/2		110			
							5/8		95			
							3/4		70			
							1		50			
							1-1/4		35			
							1-1/2		20			
							1-3/4		14			
							2		6			

Marking

Select Gases		Set Preflow		Set Cutflow		Amperage	Torch-to-Work Distance		Marking Speed		Arc Voltage
Plasma gas	Shield gas	Plasma gas	Shield gas	Plasma gas	Shield gas	Amps	mm	in	mm/m	ipm	Volts
N ₂	N ₂	10	10	10	10	18	2.5	0.10	6350	250	120
Ar	N ₂	30	10	30	10	20	3.0	0.12	2540	100	63

OPERATION

Stainless steel bevel cutting

H35 and N₂ Plasma / N₂ Shield
260 A

Flow rates – lpm/scfh		
	H35	N ₂
Preflow	0 / 0	132 / 280
Cutflow	13 / 27	163 / 345

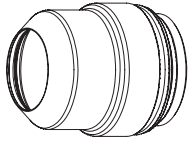

220637



220738

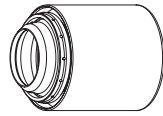

220739

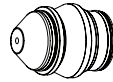

220607



220405

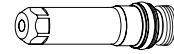

220606

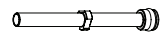

220571

Note: Bevel angle range is 0° to 45°.

Metric

Select Gases		Set Preflow		Set Cutflow				Minimum Clearance	Equivalent Material Thickness	Torch-to-Work Distance	Cutting Speed	Initial Pierce Height		Pierce Delay Time									
Plasma gas	Shield gas	Plasma gas	Shield gas	Plasma gas	Shield gas	Mix Gas 1	Mix Gas 2	mm	mm	Range (mm)	mm/m	mm	Factor %	Seconds									
H35	N ₂	12	49	87	60	60	21	2.0	6	4.0 – 10.0	3980	8.0	200	0.3									
									8		3085												
									10		2190												
									12		1790												
									15		1650												
									20		1320												
									25		920												
						32	755																
						38	510																
						44	390																
						50	270																
																		Edge start					

English

Select Gases		Set Preflow		Set Cutflow				Minimum Clearance	Equivalent Material Thickness	Torch-to-Work Distance	Cutting Speed	Initial Pierce Height		Pierce Delay Time									
Plasma gas	Shield gas	Plasma gas	Shield gas	Plasma gas	Shield gas	Mix Gas 1	Mix Gas 2	in	in	Range (in)	ipm	in	Factor %	Seconds									
H35	N ₂	12	49	87	60	60	21	0.08	1/4	0.16 – 0.40	150	0.32	200	0.3									
									5/16		121												
									3/8		90												
									1/2		65												
									5/8		55												
									3/4		35												
									1		30												
						1-1/4	20																
						1-1/2	15																
						1-3/4	10																
						2	10																
																		Edge start					

Marking

Select Gases		Set Preflow		Set Cutflow		Amperage	Torch-to-Work Distance		Marking Speed		Arc Voltage
						Amps	mm	in	mm/m	ipm	Volts
N ₂	N ₂	10	10	10	10	18	2.5	0.10	6350	250	120
Ar	N ₂	30	10	30	10	20	3.0	0.12	2540	100	63

Stainless steel
N₂ Plasma / Air Shield
400 A

Flow rates – lpm/scfh		
	N ₂	Air
Preflow	42 / 90	146 / 310
Cutflow	86 / 182	102 / 217

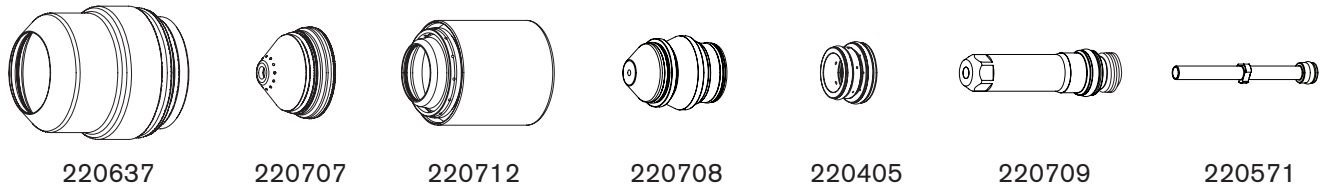

Metric

Select Gases		Set Preflow		Set Cutflow		Material Thickness	Arc Voltage	Torch-to-Work Distance	Cutting Speed	Initial Pierce Height		Pierce Delay Time						
Plasma gas	Shield gas	Plasma gas	Shield gas	Plasma gas	Shield gas					mm	Volts		mm	mm/m	mm	Factor %		
N ₂	Air	30	50	85	31	12	158	3.8	3300	9.9	260	0.3						
						15	159		2800			0.4						
						20	162		4.6	2340	13.8	300	0.5					
						25	164	1940		0.6								
						30	176	6.4	1450	19.2			0.8					
												40	177	4.6	570	Edge start		
												45	187		430			

English

Select Gases		Set Preflow		Set Cutflow		Material Thickness	Arc Voltage	Torch-to-Work Distance	Cutting Speed	Initial Pierce Height		Pierce Delay Time						
Plasma gas	Shield gas	Plasma gas	Shield gas	Plasma gas	Shield gas					in	Volts		in	ipm	in	Factor %		
N ₂	Air	30	50	85	31	1/2	158	0.15	125	0.39	260	0.3						
						5/8	159		105			0.4						
						3/4	162	0.18	95	0.54	300	0.5						
						1	164		75			0.6						
						1-1/4	176	0.25	50			0.75	0.8					
												1-1/2	177	0.18	25	Edge start		
												1-3/4	187		17			

Marking

Select Gases		Set Preflow		Set Cutflow		Amperage	Torch-to-Work Distance		Marking Speed		Arc Voltage
							mm	in	mm/m	ipm	
N ₂	N ₂	10	10	10	10	22	2.5	0.10	1270	50	94
Ar	N ₂	30	10	30	10	24	3.0	0.12	2540	100	50

OPERATION

Stainless steel H35 Plasma / N₂ Shield 400 A

Flow rates – lpm/scfh		
	H35	N ₂
Preflow	0 / 0	189 / 400
Cutflow	86 / 182	123 / 260

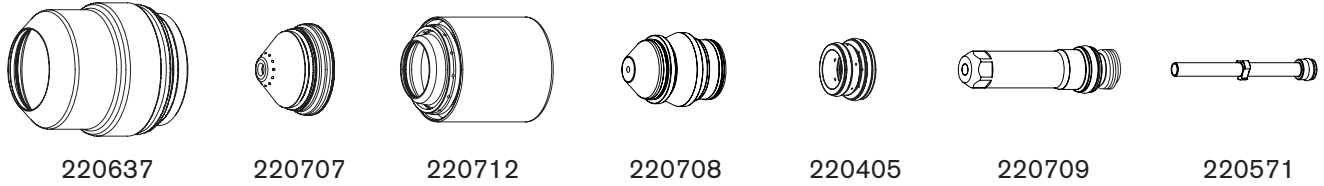

Metric

Select Gases		Set Preflow		Set Cutflow		Material Thickness	Arc Voltage	Torch-to-Work Distance	Cutting Speed	Initial Pierce Height		Pierce Delay Time
Plasma gas	Shield gas	Plasma gas	Shield gas	Plasma gas	Shield gas					mm	Volts	
H35	N ₂	30	45	86	45	20	180	9.0	1100	14.5	150	0.7
						25	181		905			
						30	184		800	19.0	210	1.5
						40	186		600			
						50	192		400			
						60	198		280			

English

Select Gases		Set Preflow		Set Cutflow		Material Thickness	Arc Voltage	Torch-to-Work Distance	Cutting Speed	Initial Pierce Height		Pierce Delay Time
Plasma gas	Shield gas	Plasma gas	Shield gas	Plasma gas	Shield gas					in	Volts	
H35	N ₂	30	45	86	45	3/4	180	0.35	45	0.53	150	0.7
						1	181		35			
						1-1/4	184		30	0.75	210	1.5
						1-1/2	186		25			
						1-3/4	189		20			
						2	192		15			
						2-1/4	198		12	Edge start		
						2-1/2	202		10	Edge start		

Marking

Select Gases		Set Preflow		Set Cutflow		Amperage	Torch-to-Work Distance		Marking Speed		Arc Voltage
							mm	in	mm/m	ipm	
N ₂	N ₂	10	10	10	10	22	2.5	0.10	1270	50	94
Ar	N ₂	30	10	30	10	24	3.0	0.12	2540	100	50

Stainless steel

H35 and N₂ Plasma / N₂ Shield
400 A

Flow rates – lpm/scfh		
	H35	N ₂
Preflow	0 / 0	194 / 410
Cutflow	36 / 77	194 / 410

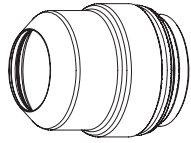

220637



220707

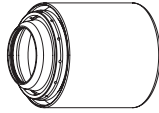

220712

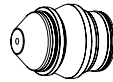

220708



220405

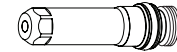

220709

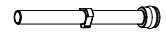

220571

Metric

Select Gases		Set Preflow		Set Cutflow				Material Thickness	Arc Voltage	Torch-to-Work Distance	Cutting Speed	Initial Pierce Height		Pierce Delay Time
Plasma gas	Shield gas	Plasma gas	Shield gas	Plasma gas	Shield gas	Mix Gas 1	Mix Gas 2	mm	Volts	mm	mm/m	mm	Factor %	Seconds
H35	N ₂	30	45	88	45	60	40	12	157	4.6	2750	14	300	0.4
								15	159					0.5
								20	166					0.7
								25	172					1.0
							60	30	186	5.3	1080	16	2.0	
								40	187	6.4	720	19	3.0	
								45						635
								50	190		520	Edge start		
								60	192		410			
								70	194		310			
								80	210		180			

English

Select Gases		Set Preflow		Set Cutflow				Material Thickness	Arc Voltage	Torch-to-Work Distance	Cutting Speed	Initial Pierce Height		Pierce Delay Time
Plasma gas	Shield gas	Plasma gas	Shield gas	Plasma gas	Shield gas	Mix Gas 1	Mix Gas 2	in	Volts	in	ipm	in	Factor %	Seconds
H35	N ₂	30	45	88	45	60	40	1/2	157	0.18	105	0.5	300	0.4
								5/8	159					0.5
								3/4	166					0.7
								1	172					1.0
							60	1-1/4	182	0.21	40	0.6	1.5	
								1-1/2	186	0.25	30	0.8	2.0	
								1-3/4	187					
								2	190		20	Edge start		
								2-1/4	192		17			
								2-1/2	194		15			
								3	202		10			

Marking

Select Gases		Set Preflow		Set Cutflow		Amperage	Torch-to-Work Distance		Marking Speed		Arc Voltage
						Amps	mm	in	mm/m	ipm	Volts
N ₂	N ₂	10	10	10	10	22	2.5	0.10	1270	50	94
Ar	N ₂	30	10	30	10	24	3.0	0.12	2540	100	50

OPERATION

Stainless steel bevel cutting

N₂ Plasma / Air Shield

400 A

Flow rates – lpm/scfh		
	N ₂	Air
Preflow	42 / 90	146 / 310
Cutflow	86 / 182	102 / 217

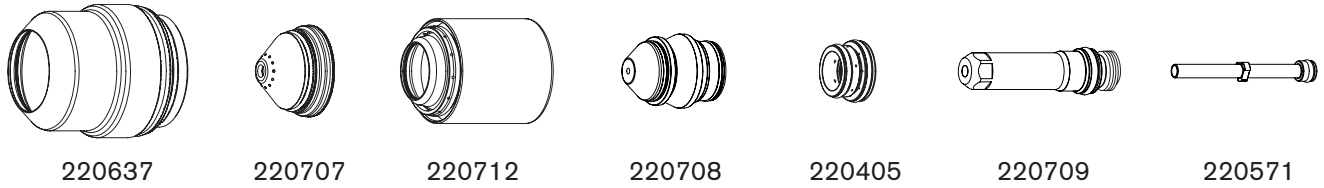

Note: Bevel angle range is 0° to 45°.

Metric

Select Gases		Set Preflow		Set Cutflow		Minimum Clearance	Equivalent Material Thickness	Torch-to-Work Distance	Cutting Speed	Initial Pierce Height		Pierce Delay Time
Plasma gas	Shield gas	Plasma gas	Shield gas	Plasma gas	Shield gas					mm	mm	
N ₂	Air	30	50	85	31	2.0	12	3.8 – 11.6	3300	9.9	260	0.3
							15		2800			0.4
							20	4.6 – 11.6	2340	13.8	300	0.5
							25		1940			0.6
							30	6.4 – 11.6	1450	19.2	0.8	
							40	4.6 – 11.6	570	Edge start		
							45		430			

English

Select Gases		Set Preflow		Set Cutflow		Minimum Clearance	Equivalent Material Thickness	Torch-to-Work Distance	Cutting Speed	Initial Pierce Height		Pierce Delay Time
Plasma gas	Shield gas	Plasma gas	Shield gas	Plasma gas	Shield gas					in	in	
N ₂	Air	30	50	85	31	0.08	1/2	0.15 – 0.46	125	0.39	260	0.3
							5/8		105			0.4
							3/4	0.18 – 0.46	95	0.54	300	0.5
							1		75			0.6
							1-1/4	0.25 – 0.46	50	0.75	0.8	
							1-1/2	0.18 – 0.46	25	Edge start		
							1-3/4		17			

Marking

Select Gases		Set Preflow		Set Cutflow		Amperage	Torch-to-Work Distance		Marking Speed		Arc Voltage
Plasma gas	Shield gas	Plasma gas	Shield gas	Plasma gas	Shield gas		Amps	mm	in	mm/m	ipm
N ₂	N ₂	10	10	10	10	22	2.5	0.10	1270	50	94
Ar	N ₂	30	10	30	10	24	3.0	0.12	2540	100	50

Stainless steel bevel cutting

H35 Plasma / N₂ Shield
400 A

Flow rates – lpm/scfh		
	H35	N ₂
Preflow	0 / 0	189 / 400
Cutflow	86 / 182	123 / 260

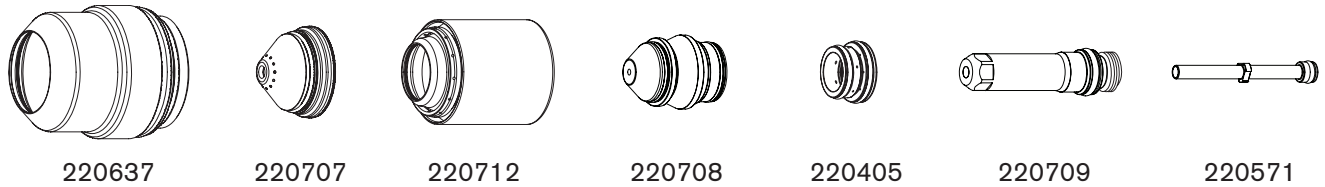

Note: Bevel angle range is 0° to 45°.

Metric

Select Gases		Set Preflow		Set Cutflow		Minimum Clearance	Equivalent Material Thickness	Torch-to-Work Distance	Cutting Speed	Initial Pierce Height		Pierce Delay Time
Plasma gas	Shield gas	Plasma gas	Shield gas	Plasma gas	Shield gas	mm	mm	Range (mm)	mm/m	mm	Factor %	Seconds
H35	N ₂	30	45	86	45	2.0	20	9.0 – 11.6	1100	14.5	150	0.7
							25		905			1.0
							30		800			1.5
							40		600			2.0
							50		400			Edge start
							60		280			

English

Select Gases		Set Preflow		Set Cutflow		Minimum Clearance	Equivalent Material Thickness	Torch-to-Work Distance	Cutting Speed	Initial Pierce Height		Pierce Delay Time
Plasma gas	Shield gas	Plasma gas	Shield gas	Plasma gas	Shield gas	in	in	Range (in)	ipm	in	Factor %	Seconds
H35	N ₂	30	45	86	45	0.08	3/4	0.35 – 0.46	45	0.53	150	0.7
							1		35			1.0
							1-1/4		30			1.5
							1-1/2		25			2.0
							1-3/4		20			Edge start
							2		15			
							2-1/4		12			
							2-1/2		10			

Marking

Select Gases		Set Preflow		Set Cutflow		Amperage	Torch-to-Work Distance		Marking Speed		Arc Voltage
						Amps	mm	in	mm/m	ipm	Volts
N ₂	N ₂	10	10	10	10	22	2.5	0.10	1270	50	94
Ar	N ₂	30	10	30	10	24	3.0	0.12	2540	100	50

OPERATION

Stainless steel bevel cutting

H35 and N₂ Plasma / N₂ Shield

400 A

Flow rates – lpm/scfh		
	H35	N ₂
Preflow	0 / 0	194 / 410
Cutflow	36 / 77	194 / 410

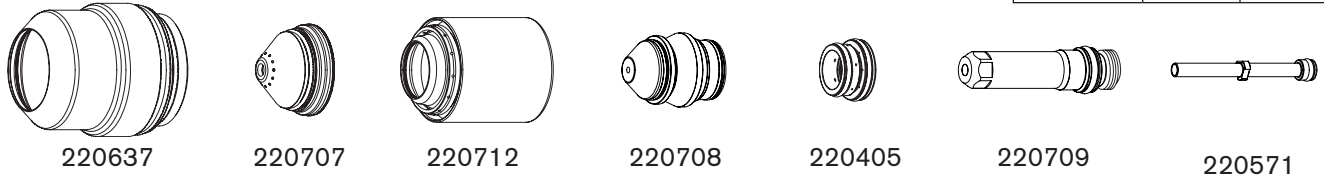

Note: Bevel angle range is 0° to 45°.

Metric

Select Gases		Set Preflow		Set Cutflow				Minimum Clearance	Equivalent Material Thickness	Torch-to-Work Distance	Cutting Speed	Initial Pierce Height		Pierce Delay Time
Plasma gas	Shield gas	Plasma gas	Shield gas	Plasma gas	Shield gas	Mix Gas 1	Mix Gas 2					mm	mm	
H35	N ₂	30	45	88	45	60	40	2.0	12	4.6 – 11.6	2750	14	300	0.4
									15		2390			0.5
									20		1810			0.7
									25		1310			1.0
							30		5.3 – 11.6	1080	16	2.0		
							40		6.4 – 11.6	720	19	3.0		
							50			Edge start				
							60							
							70							
							80		180					

English

Select Gases		Set Preflow		Set Cutflow				Minimum Clearance	Equivalent Material Thickness	Torch-to-Work Distance	Cutting Speed	Initial Pierce Height		Pierce Delay Time
Plasma gas	Shield gas	Plasma gas	Shield gas	Plasma gas	Shield gas	Mix Gas 1	Mix Gas 2					in	in	
H35	N ₂	30	45	88	45	60	40	0.08	1/2	0.18 – 0.46	105	0.5	300	0.4
									5/8		90			0.5
									3/4		75			0.7
									1		50			1.0
							1-1/4		0.21 – 0.46	40	0.6	1.5		
							1-1/2		0.25 – 0.46	30	0.8	2.0		
							1-3/4			25		3.0		
							2			Edge start				
							2-1/4							
							2-1/2							
3	10													

Marking

Select Gases		Set Preflow		Set Cutflow		Amperage	Torch-to-Work Distance		Marking Speed		Arc Voltage
Plasma gas	Shield gas	Plasma gas	Shield gas	Plasma gas	Shield gas	Amps	mm	in	mm/m	ipm	Volts
N ₂	N ₂	10	10	10	10	22	2.5	0.10	1270	50	94
Ar	N ₂	30	10	30	10	24	3.0	0.12	2540	100	50

Stainless steel – Moving pierce
H35 and N₂ Plasma / N₂ Shield
400 A



220637 220707 220712 220708 220405 220709 220571

Moving pierce (MP) parameters – metric

Material Thickness	First Segment	First Speed	Second Segment	Second Speed	Third Segment	Third Speed	Pierce Delay Time	Transfer Height Factor	Moving Delay Factor	Pierce Height Factor	End Height Factor	Torch-to-Work Distance*	Cut Height Delay	MP AVC Delay
mm		mm/m	mm	mm/m	mm	mm/m	Seconds	% Cut Height	% Pierce Delay	% Cut Height	% Cut Height	mm	Seconds	Seconds
	50	19.1	1143	381	38.1	508	4.8	300	50	500	250	6.4	0.5	5.7
75	25.3		508	508	63.5	254	8.0						3.0	4.0

Moving pierce (MP) parameters – English

Material Thickness	First Segment	First Speed	Second Segment	Second Speed	Third Segment	Third Speed	Pierce Delay Time	Transfer Height Factor	Moving Delay Factor	Pierce Height Factor	End Height Factor	Torch-to-Work Distance*	Cut Height Delay	MP AVC Delay
inch		ipm	in	ipm	in	ipm	Seconds	% Cut Height	% Pierce Delay	% Cut Height	% Cut Height	in	Seconds	Seconds
	2.0	0.75	45	15	1.5	20	4.8	300	50	500	250	0.25	0.5	5.7
3.0	1.00		20	20	2.5	10	8.0						3.0	4.0

Note: *Torch-to-work distance is equivalent to cut height

OPERATION

Stainless steel H35 Plasma / N₂ Shield 600 A

Flow rates – lpm/scfh		
	H35	N ₂
Preflow	0 / 0	113 / 240
Cutflow	76 / 160	134 / 283



Note: Pierce complete must be turned OFF for all 600 amp processes.

Metric

Select Gases		Set Preflow		Set Cutflow		Material Thickness	Arc Voltage	Torch-to-Work Distance	Cutting Speed	Initial Pierce Height		Pierce Delay Time
Plasma gas	Shield gas	Plasma gas	Shield gas	Plasma gas	Shield gas					mm	Volts	
H35	N ₂	43	13	78	43	40	189	12.7	721	25.4	200	2.0
						45	194		677			2.5
						50	197		597			3.0
						60	201		492			
						80	222		19.1			307
				100	212	10.2	187		Edge start			

English

Select Gases		Set Preflow		Set Cutflow		Material Thickness	Arc Voltage	Torch-to-Work Distance	Cutting Speed	Initial Pierce Height		Pierce Delay Time
Plasma gas	Shield gas	Plasma gas	Shield gas	Plasma gas	Shield gas					in	Volts	
H35	N ₂	43	13	78	43	1-1/2	189	0.50	29	1.0	200	2.0
						1-3/4	194		27			2.5
						2.0	197		23			3.0
						2-1/2	201		18			
						3.0	222		0.75			13
				4.0	212	0.40	7		Edge start			

Marking

Select Gases		Set Preflow		Set Cutflow		Amperage	Torch-to-Work Distance		Marking Speed		Arc Voltage
							mm	in	mm/m	ipm	
N ₂	N ₂	50	20	50	20	24	6.4	0.25	2540	100	106
Ar	N ₂	50	20	50	20	25	2.5	0.1	2540	100	57

Stainless steel bevel cutting

H35 Plasma / N₂ Shield
600 A

Flow rates – lpm/scfh		
	H35	N ₂
Preflow	0 / 0	113 / 240
Cutflow	76 / 160	134 / 283



Note: Pierce complete must be turned OFF for all 600 amp processes.
Bevel angle range is 0° to 45°.

Metric

Select Gases		Set Preflow		Set Cutflow		Minimum Clearance	Equivalent Material Thickness	Torch-to-Work Distance	Cutting Speed	Initial Pierce Height		Pierce Delay Time
Plasma gas	Shield gas	Plasma gas	Shield gas	Plasma gas	Shield gas	mm	mm	Range (mm)	mm/m	mm	Factor %	Seconds
H35	N ₂	43	13	78	43	2.0	40	12.7	721	25.4	200	2.0
							45		677			2.5
							50		597			3.0
				60	492		Edge start					
				80	307							
				100	187							

English

Select Gases		Set Preflow		Set Cutflow		Minimum Clearance	Equivalent Material Thickness	Torch-to-Work Distance	Cutting Speed	Initial Pierce Height		Pierce Delay Time
Plasma gas	Shield gas	Plasma gas	Shield gas	Plasma gas	Shield gas	in	in	Range (in)	ipm	in	Factor %	Seconds
H35	N ₂	43	13	78	43	0.08	1-1/2	0.50	29	1.0	200	2.0
							1-3/4		27			2.5
							2.0		23			3.0
				2-1/2	18		Edge start					
				3.0	13							
				4.0	7							

Marking

Select Gases		Set Preflow		Set Cutflow		Amperage	Torch-to-Work Distance		Marking Speed		Arc Voltage
						Amps	mm	in	mm/m	ipm	Volts
N ₂	N ₂	50	20	50	20	24	6.4	0.25	2540	100	106
Ar	N ₂	50	20	50	20	25	2.5	0.10	2540	100	57

OPERATION

Stainless steel N₂ Plasma / N₂ Shield 600 A

Flow rates – lpm/scfh	
N ₂	
Preflow	110 / 232
Cutflow	167 / 353



Note: Pierce complete must be turned OFF for all 600 amp processes.
Bevel angle range is 0° to 45°.

Metric

Select Gases		Set Preflow		Set Cutflow		Material Thickness	Arc Voltage	Torch-to-Work Distance	Cutting Speed	Transfer Height	Initial Pierce Height		Pierce Delay Time
Plasma gas	Shield gas	Plasma gas	Shield gas	Plasma gas	Shield gas	mm	Volts	mm	mm/m	mm	mm	Factor %	Seconds
N ₂	N ₂	43	13	50	34	40	181	9.5	970	19.1	25.4	266	2.0
						45	183	10.2	850				
				50	186	730							
				45	30	60	207	19.5	434				
				50	34	80	212	12.7	305	Edge start			

English

Select Gases		Set Preflow		Set Cutflow		Material Thickness	Arc Voltage	Torch-to-Work Distance	Cutting Speed	Transfer Height	Initial Pierce Height		Pierce Delay Time
Plasma gas	Shield gas	Plasma gas	Shield gas	Plasma gas	Shield gas	in	Volts	in	ipm	in	in	Factor %	Seconds
N ₂	N ₂	43	13	50	34	1-1/2	181	0.375	40	0.75	1.0	266	2.0
						1-3/4	183	0.400	34				
				2.0	186	28							
				45	30	2-1/2	207	0.750	16				
				50	34	3.0	206	0.500	12	Edge start			

Marking

Select Gases		Set Preflow		Set Cutflow		Amperage	Torch-to-Work Distance		Marking Speed		Arc Voltage
						Amps	mm	in	mm/m	ipm	Volts
N ₂	N ₂	30	10	30	10	24	2.5	0.10	6350	250	81
Ar	N ₂	30	10	30	10	20	3.8	0.15	2540	100	53

Stainless steel bevel cutting

N₂ Plasma / N₂ Shield
600 A

Flow rates – lpm/scfh	
N ₂	
Preflow	110 / 232
Cutflow	167 / 353

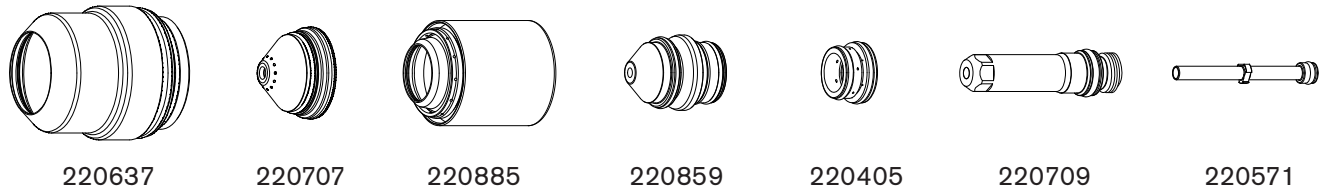

Note: Pierce complete must be turned OFF for all 600 amp processes.
Bevel angle range is 0° to 45°.

Metric

Select Gases		Set Preflow		Set Cutflow		Minimum Clearance	Material Thickness	Torch-to-Work Distance	Cutting Speed	Transfer Height	Initial Pierce Height		Pierce Delay Time
Plasma gas	Shield gas	Plasma gas	Shield gas	Plasma gas	Shield gas	mm	mm	Range (mm)	mm/m	mm	mm	Factor %	Seconds
N ₂	N ₂	43	13	50	34	2.0	40	9.5 – 11.4	970	19.1	25.4	266	2.0
							45	10.2 – 11.4	850				
				50	730								
				60	19.5		434						
				50	34		80	12.7	305				

English

Select Gases		Set Preflow		Set Cutflow		Minimum Clearance	Material Thickness	Torch-to-Work Distance	Cutting Speed	Transfer Height	Initial Pierce Height		Pierce Delay Time
Plasma gas	Shield gas	Plasma gas	Shield gas	Plasma gas	Shield gas	in	in	Range (in)	ipm	in	in	Factor %	Seconds
N ₂	N ₂	43	13	50	34	0.08	1-1/2	0.375 – 0.45	40	0.75	1.0	266	2.0
							1-3/4	0.40 – 0.45	34				
				2.0	28								
				2-1/2	0.75		16						
				50	34		3.0	0.50	12				

Marking

Select Gases		Set Preflow		Set Cutflow		Amperage	Torch-to-Work Distance		Marking Speed		Arc Voltage
						Amps	mm	in	mm/m	ipm	Volts
N ₂	N ₂	30	10	30	10	24	2.5	0.10	6350	250	81
Ar	N ₂	30	10	30	10	20	3.8	0.15	2540	100	53

Stainless steel – H35 Plasma / N₂ Shield 800 A

Flow rates – ipm/scfh		
	H35	N ₂
Preflow	0/0	123/260
Cutflow	76/160	121/257

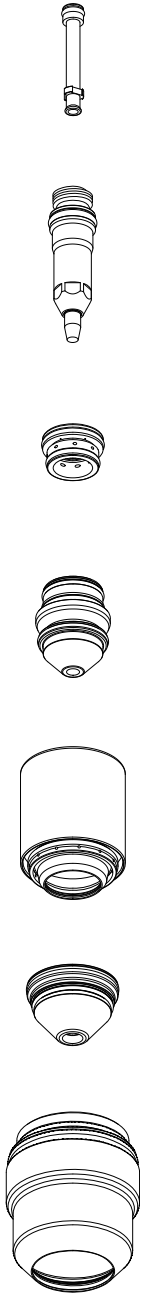

220637 220886 See chart below 220884 See chart below 220882 220881

Metric

Select Gases	Set Preflow		Set Cutflow		Material Thickness	Swirl ring Part number	Nozzle retaining cap Part number	Arc Voltage Volts	Torch-to-Work Distance mm	Cutting Speed mm/m	Transfer height mm	Pierce Height		Pierce Delay Time Seconds
	Plasma gas	Shield gas	Plasma gas	Shield gas								mm	Factor %	
H35 N ₂	64	13	69	37	50	220353	220885	172	12.7	720	19	25.4	200	3.0
					65			177		570			3.5	
					75			180		464		300	4.5	
					100			190		287		Edge start only	3.0	
					125			207		155		N/A	3.5	
					150			214		120		N/A	4.0	
160	225	100	N/A											

English

Select Gases	Set Preflow		Set Cutflow		Material Thickness	Swirl ring	Nozzle retaining cap	Arc Voltage Volts	Torch-to-Work Distance in	Cutting Speed ipm	Transfer height in	Pierce Height		Pierce Delay Time Seconds
	Plasma gas	Shield gas	Plasma gas	Shield gas								in	Factor %	
H35 N ₂	64	13	69	37	2.0	220353	220885	172	0.5	28	0.75	1.0	200	3.0
					2-1/2			177		23			3.5	
					3.0			180		18	300	4.5		
					4.0			191		11	Edge start only	3.0		
					5.0			208		6.0	N/A	3.5		
					6.0			217		4.5	N/A	4.0		
6-1/4	225	4.0	N/A											

Marking

Select Gases	Set Preflow		Set Cutflow		Amperage	Torch-to-Work Distance		Marking Speed	Arc Voltage
	Plasma gas	Shield gas	Plasma gas	Shield gas		mm	in		
N ₂	30	10	40	40	24	2.5	0.1	2540	100
Ar	30	10	40	40	24	2.5	0.1	2540	100

Note: Pierce complete must be turned OFF for all 800 amp processes. Bevel angle range is 0° to 45°.

Stainless steel bevel cutting – H35 Plasma / N₂ Shield 800 A

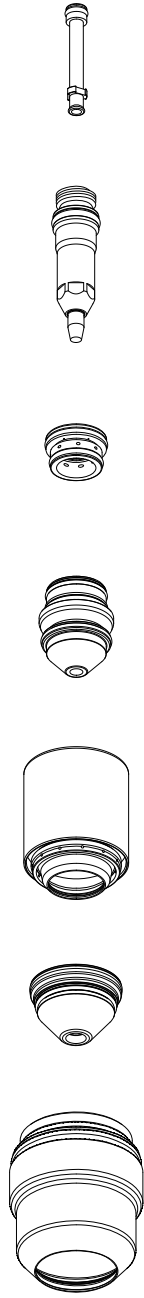

Flow rates – lpm/scfh		
	H35	N ₂
Preflow	0/0	123/260
Cutflow	76/160	121/257

Metric 220637 220886 220884 220882 220881
 See chart below See chart below

Select Gases	Set Preflow		Set Outflow	Minimum clearance	Equivalent Material Thickness	Swirl ring	Nozzle retaining cap	Torch-to-Work Distance	Cutting Speed	Transfer height	Pierce Height		Pierce Delay / Edge start delay	
	Plasma gas	Shield gas									mm	Factor %		
H35 N ₂	64	13	37	2.0	50	220353	220885	9.3 – 12.7	720	19	25.4	200	3.0	
					65				570				3.5	
					75				464				300	4.5
					100				287				N/A	3.0
					125				155				Edge start only	3.5
150	120		4.0											
160	100													

English

Select Gases	Set Preflow		Set Outflow	Minimum clearance	Material Thickness	Swirl ring	Nozzle retaining cap	Torch-to-Work Distance	Cutting Speed	Transfer height	Pierce Height		Pierce Delay Time	
	Plasma gas	Shield gas									in	Factor %		
H35 N ₂	64	13	37	0.08	2.0	220353	220885	0.37 – 0.50	28	0.75	1.0	200	3.0	
					2-1/2				23				3.5	
					3.0				18				300	4.5
					4.0				11				N/A	3.0
					5.0				6.0				Edge start only	3.5
6.0	4.5		4.0											
6-1/4	4.0													

Marking

Select Gases	Set Preflow		Set Outflow		Amperage	Torch-to-Work Distance		Marking Speed		Arc Voltage
	Plasma gas	Shield gas	Plasma gas	Shield gas		Amps	mm	in	mm/m	
N ₂	30	10	40	40	24	2.5	0.1	2540	100	79
Ar	30	10	40	40	24	2.5	0.1	2540	100	45

Note: Pierce complete must be turned OFF for all 800 amp processes. Bevel angle range is 0° to 45°.

Stainless steel – Moving pierce
H35 Plasma / N₂ Shield
800 A

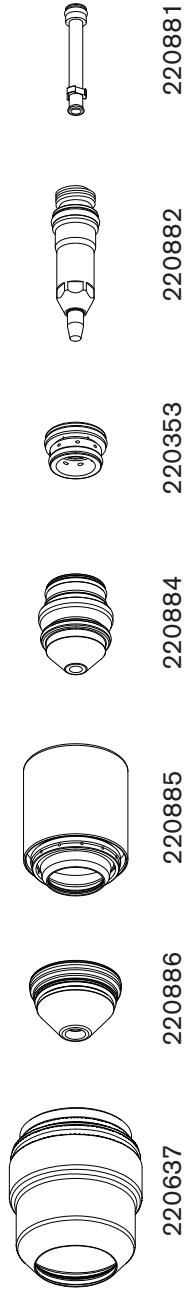

Moving pierce (MP) parameters – metric

Material Thickness	First Segment	First Speed	Second Segment	Second Speed	Third Segment	Third Speed	Pierce Delay Time	Transfer Height Factor	Moving Delay Factor	Pierce Height Factor	End Height Factor	Torch-to-Work Distance*	Cut Height Delay	MP AVC Delay
mm	mm	mm/m	mm	mm/m	mm	mm/m	Seconds	% Cut Height	% Pierce Delay	% Cut Height	% Cut Height	mm	Seconds	Seconds
100	50.8	1016	25.4	152	38.1	279	6.0	150	50	475	275	12.7	8.0	2.0

Moving pierce (MP) parameters – English

Material Thickness	First Segment	First Speed	Second Segment	Second Speed	Third Segment	Third Speed	Pierce Delay Time	Transfer Height Factor	Moving Delay Factor	Pierce Height Factor	End Height Factor	Torch-to-Work Distance*	Cut Height Delay	MP AVC Delay
inch	in	ipm	in	ipm	in	ipm	Seconds	% Cut Height	% Pierce Delay	% Cut Height	% Cut Height	in	Seconds	Seconds
4.0	2.0	40	1.0	6	1.5	11	6.0	150	50	475	275	0.5	8.0	2.0

Note: *Torch-to-work distance is equivalent to cut height

Aluminum
Air Plasma / Air Shield
45 A

Flow rates – lpm/scfh	
Air	
Preflow	45 / 95
Cutflow	78 / 165

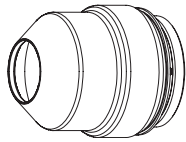

220747



220202

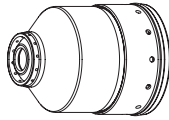

220756



220201



220180

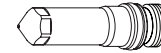

220308



220340

Metric

Select Gases		Set Preflow		Set Cutflow		Material Thickness	Arc Voltage	Torch-to-Work Distance	Cutting Speed	Initial Pierce Height		Pierce Delay Time
Plasma gas	Shield gas	Plasma gas	Shield gas	Plasma gas	Shield gas					mm	Volts	
Air	Air	35	19	62	49	1.2	130	2.5	4750	3.8	150	0.2
						1.5	115		4160			
						2	113		3865			
						2.5	110		3675			
						3	107		2850			
					33	4	102	1.8	2660	2.7		
6	117	3.0	1695	4.5	0.6							

English

Select Gases		Set Preflow		Set Cutflow		Material Thickness	Arc Voltage	Torch-to-Work Distance	Cutting Speed	Initial Pierce Height		Pierce Delay Time	
Plasma gas	Shield gas	Plasma gas	Shield gas	Plasma gas	Shield gas					in	Volts		in
Air	Air	35	19	62	49	0.040	130	0.10	220	0.15	150	0.2	
						0.051	115		170				
						0.064	113		160				
						0.102	110		140				
						33	0.125		102				0.07
					3/16	114	0.12	90	0.18	0.4			
1/4	117	60	0.6										

Marking

Select Gases		Set Preflow		Set Cutflow		Amperage	Torch-to-Work Distance		Marking Speed		Arc Voltage
Plasma gas	Shield gas	Plasma gas	Shield gas	Plasma gas	Shield gas		mm	in	mm/m	ipm	
N ₂	N ₂	10	10	10	10	15	2.5	0.10	6350	250	85
Ar	Air	90	10	90	10	12	2.5	0.10	2540	100	75

OPERATION

Aluminum Air Plasma / Air Shield 130 A

Flow rates – lpm/scfh	
Air	
Preflow	73 / 154
Cutflow	78 / 165

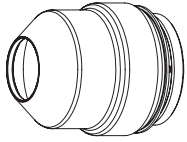

220747



220198

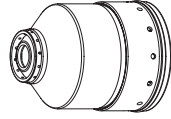

220756



220197



220179

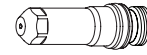

220181



220340

Metric

Select Gases		Set Preflow		Set Cutflow		Material Thickness	Arc Voltage	Torch-to-Work Distance	Cutting Speed	Initial Pierce Height		Pierce Delay Time
Plasma gas	Shield gas	Plasma gas	Shield gas	Plasma gas	Shield gas					mm	Volts	
Air	Air	19	31	75	23	6	153	2.8	2370	5.6	200	0.2
						8	154	3.0	1920	0.3		
						10			1465	0.5		
						12	156		1225	0.8		
						15	158	3.3	1050	6.6		0.8
						20	162	3.5	725	7.0		1.3
						25	172	4.0	525	Edge start		

English

Select Gases		Set Preflow		Set Cutflow		Material Thickness	Arc Voltage	Torch-to-Work Distance	Cutting Speed	Initial Pierce Height		Pierce Delay Time
Plasma gas	Shield gas	Plasma gas	Shield gas	Plasma gas	Shield gas					in	Volts	
Air	Air	19	31	75	23	1/4	153	0.11	90	0.22	200	0.2
						5/16	154	0.12	76	0.3		
						3/8			60	0.5		
						1/2	156		45	0.8		
						5/8	158	0.13	40	0.26		1.3
						3/4	162	0.14	30	0.28		
						1	172	0.16	20	Edge start		

Marking

Select Gases		Set Preflow		Set Cutflow		Amperage	Torch-to-Work Distance		Marking Speed		Arc Voltage
							mm	in	mm/m	ipm	
N ₂	N ₂	10	10	10	10	18	2.5	0.10	6350	250	120
Ar	Air	50	10	50	10	15	3.0	0.12	2540	100	82

Note: This process produces a rougher cut edge that is less perpendicular than the 130 A, H35/N₂ process.

Aluminum
H35 Plasma / N₂ Shield
130 A

Flow rates – lpm/scfh		
	H35	N ₂
Preflow	0 / 0	76 / 160
Cutflow	26 / 54	68 / 144

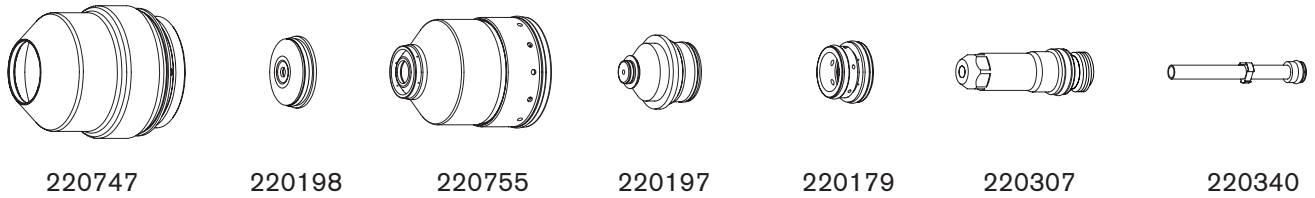

Metric

Select Gases		Set Preflow		Set Cutflow		Material Thickness	Arc Voltage	Torch-to-Work Distance	Cutting Speed	Initial Pierce Height		Pierce Delay Time
Plasma gas	Shield gas	Plasma gas	Shield gas	Plasma gas	Shield gas					mm	Volts	
H35	N ₂	19	32	75	49	8	158	5.0	1775	6.5	130	0.3
						10			1615			
					37	12	156	4.5	1455	7.7	170	0.5
						15			1305			0.8
					24	20	157		940			1.3
					16	25	176		540			Edge start

English

Select Gases		Set Preflow		Set Cutflow		Material Thickness	Arc Voltage	Torch-to-Work Distance	Cutting Speed	Initial Pierce Height		Pierce Delay Time
Plasma gas	Shield gas	Plasma gas	Shield gas	Plasma gas	Shield gas					in	Volts	
H35	N ₂	19	32	75	49	5/16	158	0.20	70	0.26	130	0.3
						3/8			65			
					37	1/2	156	0.18	55	0.31	170	0.5
						5/8			50			0.8
					24	3/4	157		40			1.3
					16	1	176		20			Edge start

Marking

Select Gases		Set Preflow		Set Cutflow		Amperage	Torch-to-Work Distance		Marking Speed		Arc Voltage
							mm	in	mm/m	ipm	
N ₂	N ₂	10	10	10	10	18	2.5	0.10	6350	250	130
Ar	N ₂	50	10	50	10	15	3.0	0.12	2540	100	75

OPERATION

Aluminum

H35 and N₂ Plasma / N₂ Shield
130 A

Flow rates – lpm/scfh		
	H35	N ₂
Preflow	0 / 0	97 / 205
Cutflow	13 / 28	71 / 150

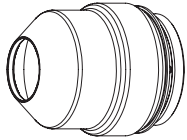

220747



220198

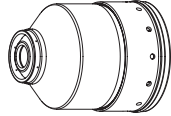

220755



220197



220179

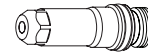

220307

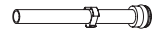

220340

Metric

Select Gases		Set Preflow		Set Cutflow				Material Thickness	Arc Voltage	Torch-to-Work Distance	Cutting Speed	Initial Pierce Height		Pierce Delay Time
Plasma gas	Shield gas	Plasma gas	Shield gas	Plasma gas	Shield gas	Mix Gas 1	Mix Gas 2	mm	Volts	mm	mm/m	mm	Factor %	Seconds
H35	N ₂	19	51	75	27	32	18	6	156	3.5	2215	7.0	200	0.3
								8	157		1915			
								10	158		1615			
								12	159	3.0	1455	6.0		0.5
								15	160		1215			0.8
								20	163		815			1.3

English

Select Gases		Set Preflow		Set Cutflow				Material Thickness	Arc Voltage	Torch-to-Work Distance	Cutting Speed	Initial Pierce Height		Pierce Delay Time
Plasma gas	Shield gas	Plasma gas	Shield gas	Plasma gas	Shield gas	Mix Gas 1	Mix Gas 2	in	Volts	in	ipm	in	Factor %	Seconds
H35	N ₂	19	51	75	27	32	18	1/4	156	0.14	85	0.28	200	0.3
								5/16	157		75			
								3/8	158		65			
								1/2	159	0.12	55	0.24		0.5
								5/8	160		45			0.8
								3/4	163		35			1.3

Marking

Select Gases		Set Preflow		Set Cutflow		Amperage	Torch-to-Work Distance		Marking Speed		Arc Voltage
						Amps	mm	in	mm/m	ipm	Volts
N ₂	N ₂	10	10	10	10	18	2.5	0.10	6350	250	130
Ar	N ₂	50	10	50	10	15	3.0	0.12	2540	100	75

Aluminum
N₂ Plasma / N₂ Shield
200 A

Flow rates – lpm/scfh	
N ₂	
Preflow	113 / 240
Cutflow	135 / 287

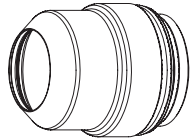

220637

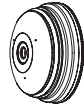

220762

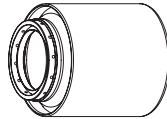

220759



220346



220342

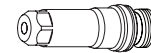

220307

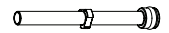

220340

Metric

Select Gases		Set Preflow		Set Cutflow		Material Thickness	Arc Voltage	Torch-to-Work Distance	Cutting Speed	Initial Pierce Height		Pierce Delay Time
Plasma gas	Shield gas	Plasma gas	Shield gas	Plasma gas	Shield gas	mm	Volts	mm	mm/m	mm	Factor %	Seconds
N ₂	N ₂	17	43	73	43	8	158	6.4	6000	9.0	140	0.3
						10			4750			0.4
						12			3500			0.5
						15			2350			0.6
						20			1000			0.8

English

Select Gases		Set Preflow		Set Cutflow		Material Thickness	Arc Voltage	Torch-to-Work Distance	Cutting Speed	Initial Pierce Height		Pierce Delay Time
Plasma gas	Shield gas	Plasma gas	Shield gas	Plasma gas	Shield gas	in	Volts	in	ipm	in	Factor %	Seconds
N ₂	N ₂	17	43	73	43	5/16	158	0.25	236	0.35	140	0.3
						3/8			200			0.4
						1/2			120			0.5
						5/8			80			0.6
						3/4			50			0.8

Marking

Select Gases		Set Preflow		Set Cutflow		Amperage	Torch-to-Work Distance		Marking Speed		Arc Voltage
						Amps	mm	in	mm/m	ipm	Volts
N ₂	N ₂	10	10	10	10	18	2.5	0.10	6350	250	140
Ar	N ₂	30	10	30	10	20	3.0	0.12	2540	100	66

OPERATION

Aluminum H35 Plasma / N₂ Shield 200 A

Flow rates – lpm/scfh		
	H35	N ₂
Preflow	0 / 0	113 / 240
Cutflow	34 / 72	90 / 190

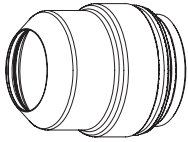

220637

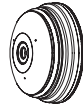

220762

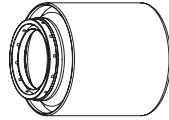

220759



220346



220342

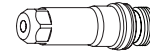

220307



220340

Metric

Select Gases		Set Preflow		Set Cutflow		Material Thickness	Arc Voltage	Torch-to-Work Distance	Cutting Speed	Initial Pierce Height		Pierce Delay Time
Plasma gas	Shield gas	Plasma gas	Shield gas	Plasma gas	Shield gas					mm	Volts	
H35	N ₂	17	43	73	43	8	152	6.4	5000	9.0	140	0.3
						10			4400			
						12	150		3800			
						15			3000			
						20	159		1450			
												0.6

English

Select Gases		Set Preflow		Set Cutflow		Material Thickness	Arc Voltage	Torch-to-Work Distance	Cutting Speed	Initial Pierce Height		Pierce Delay Time
Plasma gas	Shield gas	Plasma gas	Shield gas	Plasma gas	Shield gas					in	Volts	
H35	N ₂	17	43	73	43	5/16	152	0.25	197	0.35	140	0.3
						3/8			180			
						1/2	150		140			
						5/8			110			
						3/4	159		70			
												0.6

Marking

Select Gases		Set Preflow		Set Cutflow		Amperage	Torch-to-Work Distance		Marking Speed		Arc Voltage
							mm	in	mm/m	ipm	
N ₂	N ₂	10	10	10	10	18	2.5	0.10	6350	250	140
Ar	N ₂	30	10	30	10	20	3.0	0.12	2540	100	66

Aluminum

H35 and N₂ Plasma / N₂ Shield
200 A

Flow rates – lpm/scfh		
	H35	N ₂
Preflow	0 / 0	121 / 256
Cutflow	13 / 27	126 / 267

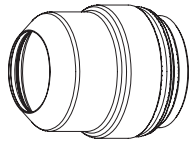

220637



220762

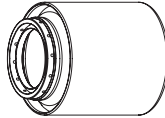

220759



220346



220342

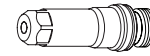

220307

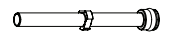

220340

Metric

Select Gases		Set Preflow		Set Cutflow				Material Thickness	Arc Voltage	Torch-to-Work Distance	Cutting Speed	Initial Pierce Height		Pierce Delay Time
Plasma gas	Shield gas	Plasma gas	Shield gas	Plasma gas	Shield gas	Mix Gas 1	Mix Gas 2	mm	Volts	mm	mm/m	mm	Factor %	Seconds
H35	N ₂	17	44	73	44	42	20	8	158	6.4	4350	9.0	140	0.3
								10			4000			
								12			3650			
								15			2450			
								20			1050			

English

Select Gases		Set Preflow		Set Cutflow				Material Thickness	Arc Voltage	Torch-to-Work Distance	Cutting Speed	Initial Pierce Height		Pierce Delay Time
Plasma gas	Shield gas	Plasma gas	Shield gas	Plasma gas	Shield gas	Mix Gas 1	Mix Gas 2	in	Volts	in	ipm	in	Factor %	Seconds
H35	N ₂	17	44	73	44	42	20	5/16	158	0.25	171	0.35	140	0.3
								3/8			160			
								1/2			140			
								5/8			80			
								3/4			50			

Marking

Select Gases		Set Preflow		Set Cutflow		Amperage	Torch-to-Work Distance		Marking Speed		Arc Voltage
						Amps	mm	in	mm/m	ipm	Volts
N ₂	N ₂	10	10	10	10	18	2.5	0.10	6350	250	140
Ar	N ₂	30	10	30	10	20	3.0	0.12	2540	100	66

OPERATION

Aluminum

N₂ Plasma / Air Shield
260 A

Flow rates – lpm/scfh		
	N ₂	Air
Preflow	125 / 265	0 / 0
Cutflow	50 / 105	113 / 240

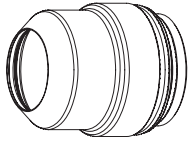

220637

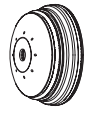

220763

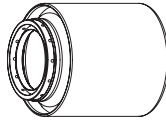

220758



220406



220405

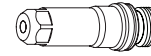

220307

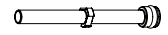

220340

Metric

Select Gases		Set Preflow		Set Cutflow		Material Thickness	Arc Voltage	Torch-to-Work Distance	Cutting Speed	Initial Pierce Height		Pierce Delay Time						
Plasma gas	Shield gas	Plasma gas	Shield gas	Plasma gas	Shield gas					mm	Volts		mm	mm/m	mm	Factor %	Seconds	
N ₂	Air	12	49	74	56	6	172	6.4	7900	9.0	140	0.2						
						8						0.3						
						10						0.4						
												12	164	4.0	4290	8.0	200	0.5
						15	0.6											
						20	0.8											
						25	0.8											
						32	0.8											
						38	0.8											
												44	202	1440	11.0	260	0.8	
												50						205

English

Select Gases		Set Preflow		Set Cutflow		Material Thickness	Arc Voltage	Torch-to-Work Distance	Cutting Speed	Initial Pierce Height		Pierce Delay Time						
Plasma gas	Shield gas	Plasma gas	Shield gas	Plasma gas	Shield gas					in	Volts		in	ipm	in	Factor %	Seconds	
N ₂	Air	12	49	74	56	1/4	172	0.25	300	0.35	140	0.2						
						5/16						0.3						
						3/8						0.4						
												1/2	164	0.16	160	0.32	200	0.5
						5/8	0.6											
						3/4	0.8											
						1	0.8											
						1-1/4	0.8											
						1-1/2	0.8											
												1-3/4	202	55	0.42	260	0.8	
												2						205

Marking

Select Gases		Set Preflow		Set Cutflow		Amperage	Torch-to-Work Distance		Marking Speed		Arc Voltage
Plasma gas	Shield gas	Plasma gas	Shield gas	Plasma gas	Shield gas	Amps	mm	in	mm/m	ipm	Volts
N ₂	N ₂	10	10	10	10	18	2.5	0.10	6350	250	120
Ar	N ₂	30	10	30	10	20	3.0	0.12	2540	100	63

Aluminum
H35 Plasma / N₂ Shield
260 A

Flow rates – lpm/scfh		
	H35	N ₂
Preflow	0 / 0	127 / 270
Cutflow	33 / 70	118 / 250

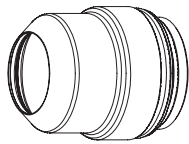

220637

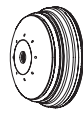

220763

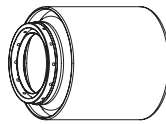

220758



220406



220405

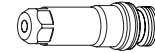

220307

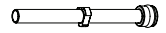

220340

Metric

Select Gases		Set Preflow		Set Cutflow		Material Thickness	Arc Voltage	Torch-to-Work Distance	Cutting Speed	Initial Pierce Height		Pierce Delay Time															
Plasma gas	Shield gas	Plasma gas	Shield gas	Plasma gas	Shield gas					mm	Volts		mm	mm/m	mm	Factor %	Seconds										
H35	N ₂	12	49	76	58	6	170	11.0	7200	11.0	100	0.2															
						8						0.3															
						10						0.4															
						H35	N ₂	12	49	76	58	12	162	10.0	5160	8.5	110	0.5									
												15						0.6									
												20						0.6									
												25						0.8									
												H35				N ₂	12	49	76	58	32	175	7.6	1510	11.0	150	0.8
																					38						
																					44						
50																											
50																											
												Edge start															

English

Select Gases		Set Preflow		Set Cutflow		Material Thickness	Arc Voltage	Torch-to-Work Distance	Cutting Speed	Initial Pierce Height		Pierce Delay Time															
Plasma gas	Shield gas	Plasma gas	Shield gas	Plasma gas	Shield gas					in	Volts		in	ipm	in	Factor %	Seconds										
H35	N ₂	12	49	76	58	1/4	170	0.45	280	0.45	100	0.2															
						5/16						0.3															
						3/8						0.4															
						H35	N ₂	12	49	76	58	1/2	162	0.30	190	0.33	110	0.5									
												5/8						0.6									
												3/4						0.6									
												1						0.8									
												H35				N ₂	12	49	76	58	1-1/4	175	0.30	75	0.45	150	0.8
																					1-1/2						
																					1-3/4						
2																											
2																											
												Edge start															

Marking

Select Gases		Set Preflow		Set Cutflow		Amperage	Torch-to-Work Distance		Marking Speed		Arc Voltage
Plasma gas	Shield gas	Plasma gas	Shield gas	Plasma gas	Shield gas		mm	in	mm/m	ipm	
N ₂	N ₂	10	10	10	10	18	2.5	0.10	6350	250	120
Ar	N ₂	30	10	30	10	20	3.0	0.12	2540	100	63

OPERATION

Aluminum N₂ Plasma / Air Shield 400 A

Flow rates – lpm/scfh		
	N ₂	Air
Preflow	42 / 90	146 / 310
Cutflow	68 / 144	103 / 219

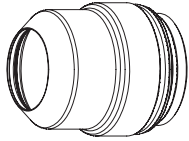

220637

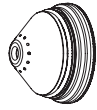

220707

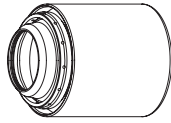

220712

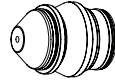

220708



220405

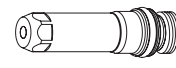

220709

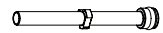

220571

Metric

Select Gases		Set Preflow		Set Cutflow		Material Thickness	Arc Voltage	Torch-to-Work Distance	Cutting Speed	Initial Pierce Height		Pierce Delay Time						
Plasma gas	Shield gas	Plasma gas	Shield gas	Plasma gas	Shield gas					mm	Volts		mm	mm/m	mm	Factor %	Seconds	
N ₂	Air	30	50	70	31	12	155	3.8	4480	12.5	330	0.4						
						15	159		3770			0.5						
						20	163		2740	0.6								
												25	169	4.1	1850	18.0	440	0.7
						30	175	1410	Edge start									
						40	188	810										
						50	206	410										

English

Select Gases		Set Preflow		Set Cutflow		Material Thickness	Arc Voltage	Torch-to-Work Distance	Cutting Speed	Initial Pierce Height		Pierce Delay Time
Plasma gas	Shield gas	Plasma gas	Shield gas	Plasma gas	Shield gas					in	Volts	
N ₂	Air	30	50	70	31	1/2	155	0.15	170	0.5	330	0.4
						5/8	159		140			0.5
						3/4	163	0.16	115	0.7	440	0.6
						1	169		70			0.7
						1-1/4	177		50	Edge start		
						1-1/2	178		35			
						1-3/4	198	25				
						2	206	16				

Marking

Select Gases		Set Preflow		Set Cutflow		Amperage	Torch-to-Work Distance		Marking Speed		Arc Voltage
							mm	in	mm/m	ipm	
N ₂	N ₂	10	10	10	10	22	2.5	0.10	1270	50	94
Ar	N ₂	30	10	30	10	24	3.0	0.12	2540	100	50

Aluminum

H35 Plasma / N₂ Shield
400 A

Flow rates – lpm/scfh		
	N ₂	Air
Preflow	0 / 0	189 / 400
Cutflow	86 / 182	123 / 260

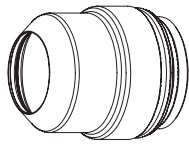

220637

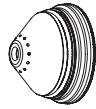

220707

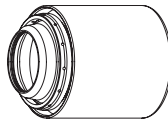

220712

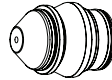

220708



220405



220709

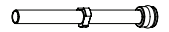

220571

Metric

Select Gases		Set Preflow		Set Cutflow		Material Thickness	Arc Voltage	Torch-to-Work Distance	Cutting Speed	Initial Pierce Height		Pierce Delay Time
Plasma gas	Shield gas	Plasma gas	Shield gas	Plasma gas	Shield gas					mm	Volts	
H35	N ₂	30	45	86	45	20	170	9.0	2420	18.9	150	0.7
						25	175		1820			1.0
						30	177		1590			1.5
						40	180		1190			2.0
						50	188		790	Edge start		
						60	200		450			
						70	208		310			
						80	210		210			

English

Select Gases		Set Preflow		Set Cutflow		Material Thickness	Arc Voltage	Torch-to-Work Distance	Cutting Speed	Initial Pierce Height		Pierce Delay Time
Plasma gas	Shield gas	Plasma gas	Shield gas	Plasma gas	Shield gas					in	Volts	
H35	N ₂	30	45	86	45	3/4	170	0.35	100	0.74	150	0.7
						1	175		70			1.0
						1-1/4	177		60			1.5
						1-1/2	180		50			2.0
						1-3/4	184		40	Edge start		
						2	188		30			
						2-1/4	200		20			
						2-1/2	208		15			
3	210	10										

Marking

Select Gases		Set Preflow		Set Cutflow		Amperage	Torch-to-Work Distance		Marking Speed		Arc Voltage
N ₂	N ₂	10	10	10	10		Amps	mm	in	mm/m	
N ₂	N ₂	10	10	10	10	22	2.5	0.10	1270	50	94
Ar	N ₂	30	10	30	10	24	3.0	0.12	2540	100	50

OPERATION

Aluminum

H35 and N₂ Plasma / N₂ Shield
400 A

Flow rates – lpm/scfh		
	H35	N ₂
Preflow	0 / 0	194 / 410
Cutflow	36 / 77	194 / 410

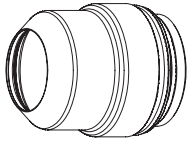

220637

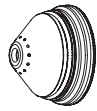

220707

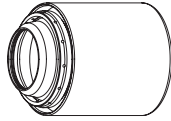

220712

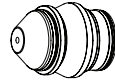

220708



220405

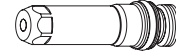

220709



220571

Metric

Select Gases		Set Preflow		Set Cutflow				Material Thickness	Arc Voltage	Torch-to-Work Distance	Cutting Speed	Initial Pierce Height		Pierce Delay Time
Plasma gas	Shield gas	Plasma gas	Shield gas	Plasma gas	Shield gas	Mix Gas 1	Mix Gas 2					mm	Volts	
H35	N ₂	30	45	88	45	60	40	12	155	4.6	5190	14	300	0.4
								15	157					0.5
								20	159					0.7
								25	166					1.0
							60	30	171	5.3	2170	16	1.5	
								40	175	6.4	1440	19	2.0	
								50	185		Edge start			
								60	195					
								70	200					
								80	208	210				

English

Select Gases		Set Preflow		Set Cutflow				Material Thickness	Arc Voltage	Torch-to-Work Distance	Cutting Speed	Initial Pierce Height		Pierce Delay Time
Plasma gas	Shield gas	Plasma gas	Shield gas	Plasma gas	Shield gas	Mix Gas 1	Mix Gas 2					in	Volts	
H35	N ₂	30	45	88	45	60	40	1/2	155	0.18	200	0.5	300	0.4
								5/8	157					0.5
								3/4	159					0.7
								1	166					1.0
							60	1-1/4	171	0.21	80	0.6	1.5	
								1-1/2	175	0.25	60	0.8	2.0	
								1-3/4	180		Edge start			
								2	185					
								2-1/4	195					
								2-1/2	200					
								3	208	10				

Marking

Select Gases		Set Preflow		Set Cutflow		Amperage	Torch-to-Work Distance		Marking Speed		Arc Voltage
							mm	in	mm/m	ipm	
N ₂	N ₂	10	10	10	10	22	2.5	0.10	1270	50	94
Ar	N ₂	30	10	30	10	24	3.0	0.12	2540	100	50

Aluminum
H35 Plasma / N₂ Shield
600 A

Flow rates – lpm/scfh		
	H35	N ₂
Preflow	0 / 0	113 / 240
Cutflow	57 / 121	134 / 283



Note: Pierce complete must be turned OFF for all 600 A processes.

Metric

Select Gases		Set Preflow		Set Cutflow		Material Thickness	Arc Voltage	Torch-to-Work Distance	Cutting Speed	Initial Pierce Height		Pierce Delay Time						
Plasma gas	Shield gas	Plasma gas	Shield gas	Plasma gas	Shield gas	mm	Volts	mm	mm/m	mm	Factor %	Seconds						
H35	N ₂	43	13	68	43	40	173	10.2	1791	25.4	250	1.0						
						45	178		1502			1.5						
						50	181		1302			2.0						
													60	189	839	Edge start		
												80	206	464				
												100	208	378				

English

Select Gases		Set Preflow		Set Cutflow		Material Thickness	Arc Voltage	Torch-to-Work Distance	Cutting Speed	Initial Pierce Height		Pierce Delay Time						
Plasma gas	Shield gas	Plasma gas	Shield gas	Plasma gas	Shield gas	in	Volts	in	ipm	in	Factor %	Seconds						
H35	N ₂	43	13	68	43	1-1/2	173	0.4	75	1.0	250	1.0						
						1-3/4	178		60			1.5						
						2.0	181		50			2.0						
													2-1/2	189	30	Edge start		
												3.0	206	19				
												4.0	208	14				

Marking

Select Gases		Set Preflow		Set Cutflow		Amperage	Torch-to-Work Distance		Marking Speed		Arc Voltage
Plasma gas	Shield gas	Plasma gas	Shield gas	Plasma gas	Shield gas	Amps	mm	in	mm/m	ipm	Volts
N ₂	N ₂	50	20	60	35	24	1.8	0.07	1270	50	106

OPERATION

Aluminum N₂ Plasma / N₂ Shield 600 A

Flow rates – lpm/scfh	
N ₂	
Preflow	110 / 232
Cutflow	167 / 353



Note: Pierce complete must be turned OFF for all 600 A processes.

Metric

Select Gases		Set Preflow		Set Cutflow		Material Thickness	Arc Voltage	Torch-to-Work Distance	Cutting Speed	Transfer Height	Initial Pierce Height		Pierce Delay Time
Plasma gas	Shield gas	Plasma gas	Shield gas	Plasma gas	Shield gas						mm	Volts	
N ₂	N ₂	43	13	50	34	40	185	9.5	1448	19.1	25.4	266	2.0
						45	196	12.7	1248				
						50	195	10.2	1048				
						60	209	12.7	832				
						80	212		600				

English

Select Gases		Set Preflow		Set Cutflow		Material Thickness	Arc Voltage	Torch-to-Work Distance	Cutting Speed	Transfer Height	Initial Pierce Height		Pierce Delay Time
Plasma gas	Shield gas	Plasma gas	Shield gas	Plasma gas	Shield gas						in	Volts	
N ₂	N ₂	43	13	50	34	1-1/2	185	0.375	60	0.75	1.0	266	2.0
						1-3/4	196	0.500	50				
						2.0	195	0.400	40				
						2-1/2	209	0.500	30				
						3.0	212		26				

Marking

Select Gases		Set Preflow		Set Cutflow		Amperage	Torch-to-Work Distance		Marking Speed		Arc Voltage
Plasma gas	Shield gas	Plasma gas	Shield gas	Plasma gas	Shield gas		mm	in	mm/m	ipm	
N ₂	N ₂	30	10	60	35	24	1.8	0.07	1270	50	81

Aluminum – H35 Plasma / N₂ Shield 800 A

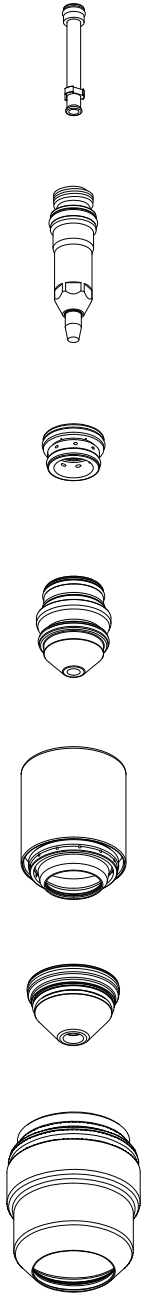

Flow rates – lpm/scfh	
H35	N ₂
Preflow	0/0 123/260
Cutflow	76/160 121/257

220637 220886 220884 See chart below 220882 220881

Metric

Select Gases	Set Preflow		Set Cutflow		Material Thickness	Swirl ring Part number	Nozzle retaining cap Part number	Arc Voltage Volts	Torch-to-Work Distance mm	Cutting Speed mm/m	Transfer height mm	Pierce Height		Pierce Delay Time Seconds	
	Plasma gas	Shield gas	Plasma gas	Shield gas								mm	Factor %		
H35	N ₂	64	13	69	37	220353	220885	166	12.7	1540	19	25.4	200	1.0	
								173		1225		38.1	300	2.0	
								187	16.0	907	N/A	N/A	Edge start only	240	2.5
								204		524					
								217	9.7	258	200	3.5			
								232		179			4.0		
239															

English

Select Gases	Set Preflow		Set Cutflow		Material Thickness	Swirl ring Part number	Nozzle retaining cap Part number	Arc Voltage Volts	Torch-to-Work Distance in	Cutting Speed ipm	Transfer height in	Pierce Height		Pierce Delay Time Seconds	
	Plasma	Shield	Plasma	Shield								in	Factor %		
H35	N ₂	64	13	69	37	220353	220885	166	0.50	60	0.75	1.0	200	1.0	
								171		50		1.5	300	2.0	
								188	0.63	35	N/A	N/A	Edge start only	240	2.5
								205		20					
								218	0.38	10	8	3.5			
								233		7			4.0		
239															

Marking

Select Gases	Set Preflow			Set Cutflow			Amperage	Torch-to-Work Distance		Marking Speed	Arc Voltage
	Plasma	Shield	Shield	Plasma	Shield	mm		in	mm/m		
N ₂	30	10	60	35	1.8	0.07	24	1270	50	79	

Note: Pierce complete must be turned OFF for all 800 amp processes.

This page is blank intentionally

Section 5

MAINTENANCE

In this section

Introduction	5-3
Routine maintenance.....	5-3
System description.....	5-4
Power and signal cables.....	5-4
Sequence of operation	5-5
Gas system purge cycle.....	5-6
Gas system valve usage.....	5-6
Marking process	5-8
Power supply troubleshooting	5-9
Error codes.....	5-10
Error code troubleshooting – error codes 000 to 018	5-11
Error code troubleshooting – error codes 020 to 028, 224 to 228.....	5-12
Error code troubleshooting – error codes 030 to 042, 231 to 234.....	5-13
Error code troubleshooting – error codes 044 to 046	5-14
Error code troubleshooting – error codes 047 to 053, 248 to 250.....	5-15
Error code troubleshooting – error codes 054 to 061	5-16
Error code troubleshooting – error codes 062 to 067, 265 to 267.....	5-17
Error code troubleshooting – error codes 071 to 075, 273 to 275.....	5-18
Error code troubleshooting – error codes 076 to 101, 276 to 301.....	5-19
Error code troubleshooting – error codes 102 to 111, 302 to 308.....	5-20
Error code troubleshooting – error codes 116 to 133, 316.....	5-21
Error code troubleshooting – error codes 134 to 140, 334 and 338.....	5-22
Error code troubleshooting – error codes 141 to 152, 346 to 351.....	5-23
Error code troubleshooting – error codes 153 to 156, 354 to 356.....	5-24
Error code troubleshooting – error codes 157 to 159, 357 to 359.....	5-25
Error code troubleshooting – error codes 160 to 180	5-26
Error code troubleshooting – error code 181, 182, 298, and 383.....	5-27
Power supply states.....	5-28
Plasma system operation with pump time-out.....	5-29
CNC operation with pump time-out.....	5-30
Initial checks.....	5-31
Power measurement	5-32



MAINTENANCE

Air filter element replacement	5-33
Coolant system servicing	5-34
Draining the coolant system.....	5-34
Chiller interface coolant filter	5-36
Filter replacement.....	5-36
Gas leak tests	5-37
Leak test 1 (inlet leak test)	5-37
Leak test 2 (system leak test).....	5-38
Leak test 3 (proportional valve test in the metering console)	5-38
Power supply control board PCB3.....	5-39
Power supply power distribution board PCB2	5-40
Start-circuit PCB1	5-41
Operation	5-41
Start circuit functional schematic	5-41
Start circuit troubleshooting	5-41
Pilot arc current levels.....	5-43
Pilot arc relay wiring	5-43
Pump motor drive board PCB7	5-44
Chiller interface power distribution board PCB1	5-45
Coolant sensor board PCB2	5-46
Selection console control board PCB2.....	5-47
Selection console power distribution board PCB1	5-48
Selection console, AC valve-driver board PCB3	5-49
Metering console control board PCB2.....	5-50
Metering console power distribution board PCB1	5-51
Chopper tests.....	5-52
Phase-loss detection test	5-54
Test continuity between the nozzle and workpiece	5-55
Preventive maintenance.....	5-56

Introduction

Hypertherm assumes that the service personnel performing the troubleshooting testing are high-level electronic service technicians who have worked with high-voltage electromechanical systems. Knowledge of final isolation troubleshooting techniques is also assumed.

In addition to being technically qualified, maintenance personnel must perform all testing with safety in mind. Refer to the *Safety* section for operating precautions and warning formats.

		<p>WARNING SHOCK HAZARD</p>
<p>Use extreme care when working near the chopper modules. Each large electrolytic capacitor (blue-cased cylinder) stores large amounts of energy in the form of electric voltage. Even if the power is off, dangerous voltages exist at the capacitor terminals, on the chopper, and the diode heatsinks. Never discharge any capacitor with a screwdriver or other implement... explosion, property damage and/or personal injury will result.</p>		

Routine maintenance

See *Preventive Maintenance*, located at the end of this section, for maintenance information. Contact the Technical Services department listed at the front of this manual with any questions regarding maintenance procedures.

System description

Power and signal cables

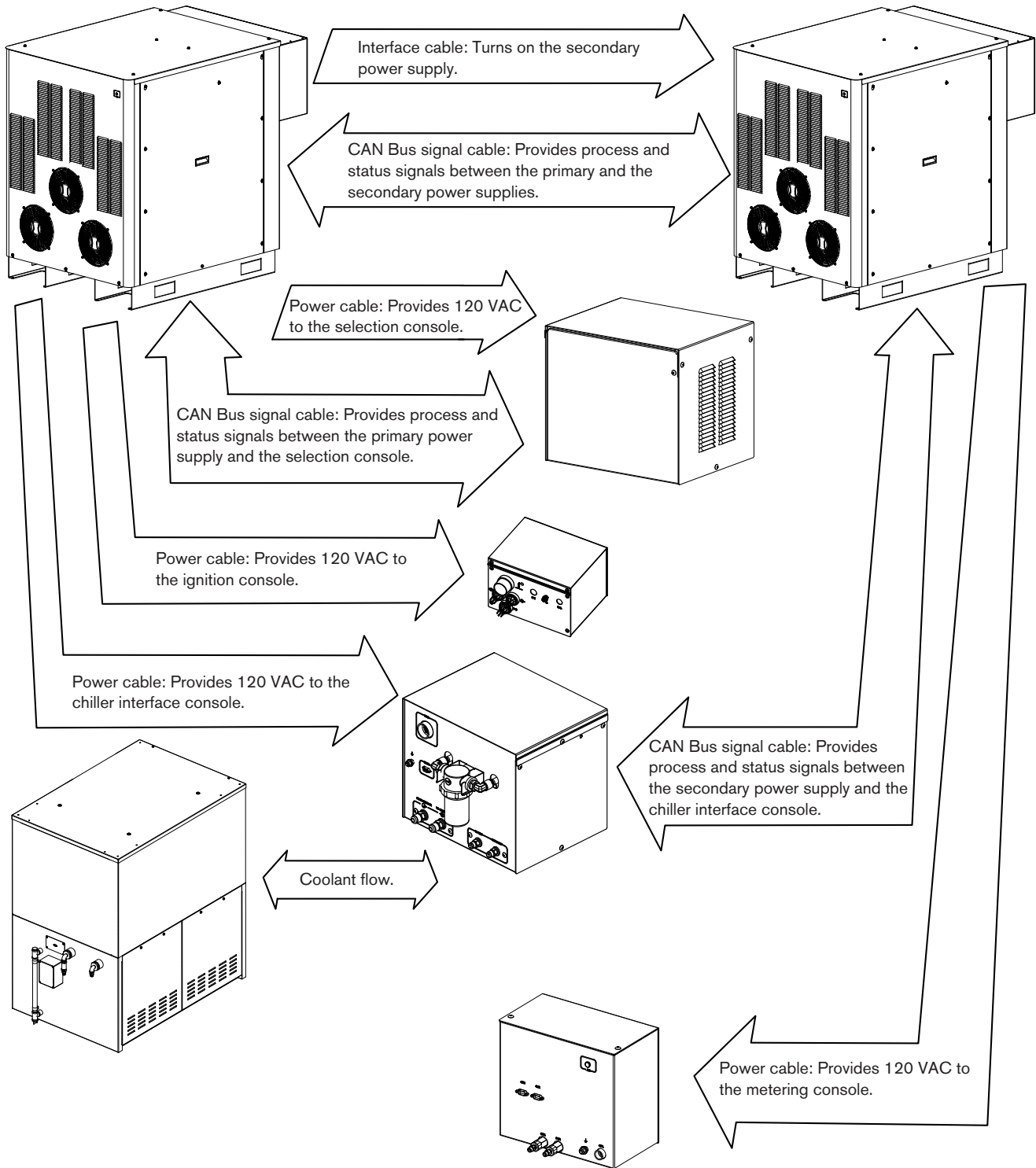

Sequence of operation

1. Power-up – The system verifies that all of these signals are off at power-up
 - Coolant flow off
 - Chopper current off
 - Transfer off
 - Phase Loss off
 - Chopper 1 over-temp off
 - Magnetics over-temp off
 - Coolant over-temp off
 - Plasma start off
2. Purge – Air or N₂ gas flows through torch for 20 seconds
 - Coolant flow on
 - Primary contactor closes and the chopper performs a chopper test and a current sensor test
 - Secondary contactor closes and the system tests the secondary choppers and current sensors
 - Plasma start off
 - Both contactors remain closed in the next state
3. Idle
 - Gas pressure ok
 - Coolant flow on
 - Chopper current off
 - Line voltage ok
4. Preflow – 2 second flow of gas
 - Primary and secondary contactors are closed
5. Pilot Arc – Current flow between electrode and nozzle
 - Chopper, main contactor and pilot arc relay are on
 - High frequency present
 - Chopper current sensor = pilot arc current
6. Transfer – Pilot arc current sensed on the worklead
7. Ramp-up – Primary chopper current increases to set point and gas changes to cutflow
 - Coolant flow on
 - Gas pressure ok
 - Phase loss on
 - Line voltage ok
 - After the primary choppers reach maximum current (400 amps), the secondary choppers increase current output (if necessary) to a final setpoint
8. Steady State – normal operating parameters
 - Coolant flow on
 - Gas pressure ok
 - Phase loss on
 - Chopper 1 over-temp off
 - Magnetics over-temp off
 - Coolant over-temp off
9. Ramp-down – Current and gas flow decreases after plasma start has been removed
 - Cutflow gas off
10. Auto Off – 10 second postflow
 - Main contactors off
 - Choppers off

Gas system purge cycle

When the system is turned on, or the operator changes from one cut process to another, the system automatically goes through a purge cycle. The purge cycle has 2 stages; a preflow purge and a cutflow purge.

The preflow purge gas flows for 8 seconds with an auto gas console, or 12 seconds with a manual gas console.

The cutflow purge gas flows for 8 seconds with an auto gas console, or 12 seconds with a manual gas console.

There are 2 exceptions to the cycle described above.

Exception 1 – if the operator changes from a non-fuel gas process (O₂/Air, Air/Air, or N₂/Air) to a fuel gas process (H35/N₂, or F5/N₂) or the reverse, there will be 3 stages to the purge process. Nitrogen will purge the gas system first, for 12 seconds. The preflow and cutflow purges will follow the nitrogen purge.

Note: Error code 42 (low nitrogen gas pressure) will be displayed, if nitrogen is not connected to the gas system. If error code 42 is not resolved in 3 minutes, it will be replaced by error code 139 (purge time-out error).

Exception 2 – no purge cycle will occur if the operator changes from any cut process to a nitrogen or argon marking process.

Gas system valve usage

The following tables show which valves are active for each cutting process.

O ₂ /O ₂ process	Metering console control board				Selection console control board															
					1	2	3	4	5	6	7	8	9	10	11	12	13	14	15	16
LED number	38	39	28	37	1	2	3	4	5	6	7	8	9	10	11	12	13	14	15	16
Preflow	B4		B2		SV1		SV3					SV8		SV10						
Cutflow		B3		B1	SV1		SV3					SV8		SV10						

O ₂ /Air process	Metering console control board				Selection console control board															
					1	2	3	4	5	6	7	8	9	10	11	12	13	14	15	16
LED number	38	39	28	37	1	2	3	4	5	6	7	8	9	10	11	12	13	14	15	16
Preflow	B4		B2		SV1		SV3					SV8		SV10						
Cutflow		B3	B2		SV1		SV3					SV8		SV10						

N ₂ /N ₂ process	Metering console control board				Selection console control board															
					1	2	3	4	5	6	7	8	9	10	11	12	13	14	15	16
LED number	38	39	28	37	1	2	3	4	5	6	7	8	9	10	11	12	13	14	15	16
Preflow	B4			B1									SV9		SV11					
Cutflow	B4			B1									SV9		SV11					

F5/N ₂ process	Metering console control board				Selection console control board															
LED number	38	39	28	37	1	2	3	4	5	6	7	8	9	10	11	12	13	14	15	16
Preflow		B3		B1						SV6			SV9							
Cutflow	B4			B1						SV6			SV9					SV14		

H35/N ₂ process	Metering console control board				Selection console control board															
LED number	38	39	28	37	1	2	3	4	5	6	7	8	9	10	11	12	13	14	15	16
Preflow		B3		B1					SV5				SV9							
Cutflow	B4			B1					SV5				SV9					SV14		

H35 & N ₂ /N ₂ process	Metering console control board				Selection console control board															
LED number	38	39	28	37	1	2	3	4	5	6	7	8	9	10	11	12	13	14	15	16
Preflow		B3		B1					SV5				SV9							
Cutflow	B4			B1					SV5				SV9			SV12	SV13			

N ₂ /Air process	Metering console control board				Selection console control board															
LED number	38	39	28	37	1	2	3	4	5	6	7	8	9	10	11	12	13	14	15	16
Preflow		B3	B2				SV3						SV9	SV10						
Cutflow		B3	B2				SV3						SV9	SV10						

Air/Air process	Metering console control board				Selection console control board															
LED number	38	39	28	37	1	2	3	4	5	6	7	8	9	10	11	12	13	14	15	16
Preflow		B3	B2			SV2	SV3					SV8		SV10						
Cutflow		B3	B2			SV2	SV3					SV8		SV10						

MAINTENANCE

Marking process

The valves that are active when marking are represented by the tables below. The active valves in the metering console will differ depending on what process was used before marking.

Valves active when changing from a process that **does not** use a fuel gas

N ₂ /N ₂	Metering console control board				Selection console control board																
	LED number	38	39	28	37	1	2	3	4	5	6	7	8	9	10	11	12	13	14	15	16
Preflow	B4		B2													SV11					
Cutflow	B4		B2													SV11					

Valves active when changing from a process that **does** use a fuel gas

N ₂ /N ₂	Metering console control board				Selection console control board																
	LED number	38	39	28	37	1	2	3	4	5	6	7	8	9	10	11	12	13	14	15	16
Preflow		B3		B1										SV9							
Cutflow		B3		B1										SV9							

Ar/N ₂	Metering console control board				Selection console control board																
	LED number	38	39	28	37	1	2	3	4	5	6	7	8	9	10	11	12	13	14	15	16
Preflow	B4			B1										SV9							SV15
Cutflow	B4			B1										SV9							SV15

Ar/Air 25 to 35 amps	Metering console control board				Selection console control board																
	LED number	38	39	28	37	1	2	3	4	5	6	7	8	9	10	11	12	13	14	15	16
Preflow	B4		B2					SV3				SV7			SV10						
Cutflow	B4		B2					SV3				SV7			SV10						

Ar/Air < 25 or > 35 amps	Metering console control board				Selection console control board																
	LED number	38	39	28	37	1	2	3	4	5	6	7	8	9	10	11	12	13	14	15	16
Preflow		B3	B2					SV3				SV7			SV10						
Cutflow		B3	B2					SV3				SV7			SV10						

Power supply troubleshooting

If one of the power supplies in an HPR800XD system fails, the system can still be used for cutting with processes up to 400 amps. The primary and secondary power supplies are identical except for the control board. The power supply control boards can not be interchanged.

If the secondary power supply fails, turn OFF the main disconnect to the secondary power supply, and use the system as a 400 amp system. All power to the secondary power supply must be turned off.

If the primary power supply fails, use parts (except the control board) from the secondary power supply to fix the primary power supply. The system can now be used as a 400 amp system.

Error codes

Errors that can be generated by either the primary power supply or the secondary power supply will have 2 entries in the error code number column. The first number will represent the primary power supply and the second will represent the secondary power supply. The secondary error code entry equals the primary error code number plus 200.

See the example below:

Error code number	Name	Description	Corrective action
102 Primary	Chopper 1 current at power-up	Chopper 1 current signal is active at power-up	See wiring diagrams in section 7 1. Verify that the voltage at CS1 is correct. 2. Verify that the wiring between CS1 and PCB3 is correct and not damaged. 3. Swap CS1 with CS2. If the error code changes to 156, replace the original CS1.
302 Secondary			

Error codes are displayed on the CNC screen. The diagnostic screen shown below is for reference. The screens you work with may be different, but should include the functions described in the *Operation* section of this manual.

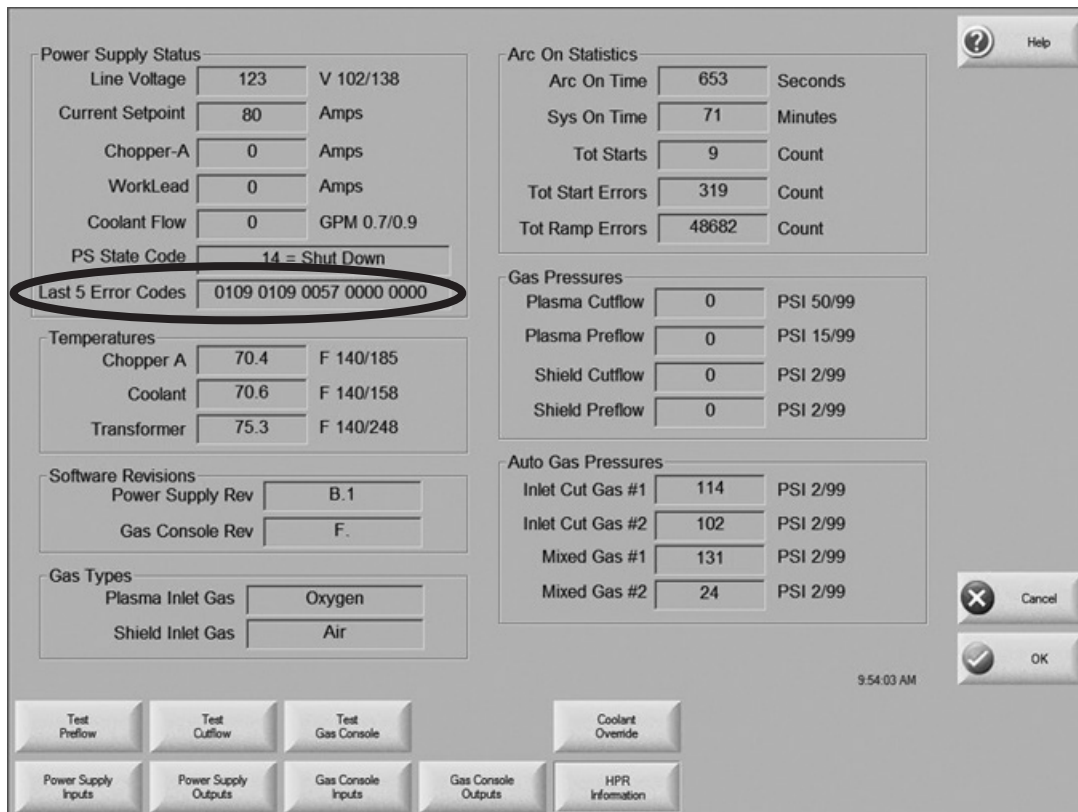

Error code troubleshooting – error codes 000 to 018

Error code number	Name	Description	Corrective action
000	No error	System is ready to run.	None needed.
009	Flow switch test	The flow switch is tested when the pump restarts after a pump timeout (30 minutes without a start signal). The test ensures that the coolant flow is correct before firing the torch.	Wait 10 seconds for the flow rate to stabilize.
011	No active process HPR400XD HPR800XD Only	The current setting is greater than the capability of the selected process. When this error code occurs, the power supply will ignore the start signal until a correct process is chosen.	1. Verify that the secondary power supply is turned ON. 2. Verify that the current for the selected process is within the range of the power supply capability (up to 400A for 400XD, and up to 800A for 800XD).
012	Test in progress	One of the gas test modes is running.	Wait for the test to finish.
013	Test passed	The test was successful.	No action required.
014	Cut gas channel 1 fail	The gas pressure in channel 1 is decreasing, which indicates a leak.	Look for leaks and loose connections between the selection console and the metering console.
015	Cut gas channel 2 fail	The gas pressure in channel 2 is decreasing, which indicates a leak.	Look for leaks and loose connections between the selection console and the metering console.
016	Plasma rampdown fail	Plasma pressure did not decrease in the time allowed.	Verify that there is no obstruction in the plasma vent hose.
017	Shield rampdown fail	Shield pressure did not decrease in the time allowed.	Inspect the holes in the shield for obstructions. Replace the shield if the holes are blocked.

Error code troubleshooting – error codes 020 to 028, 224 to 228

Error code number	Name	Description	Corrective action
020	No pilot arc	No current detected from chopper at ignition and before 1-second timeout.	<ol style="list-style-type: none"> 1. Verify that the consumable parts are in good condition. 2. Verify proper preflow and cut-flow settings. 3. Perform gas leak tests (see <i>Maintenance</i> section). 4. Verify spark across spark gap. 5. Inspect CON1 and pilot arc relay for excessive wear. 6. Perform gas flow test (see <i>Maintenance</i> section). 7. Perform continuity test between the nozzle and the workpiece (see <i>Maintenance</i> section). 8. Perform start circuit test (see <i>Maintenance</i> section).
021	No arc transfer	No current detected on work lead 500 milliseconds after pilot arc current was established.	<ol style="list-style-type: none"> 1. Verify proper pierce height. 2. Verify proper preflow and cut-flow settings. 3. Inspect work lead for damage or loose connections. 4. Verify the pilot arc relay is wired correctly (see <i>Maintenance</i> section).
024 Primary 224 Secondary	Lost current Chopper 1	Lost the current signal from Chopper 1 after transfer.	<ol style="list-style-type: none"> 1. Verify that the consumable parts are in good condition. 2. Verify proper cut-flow gas settings. 3. Verify pierce delay time. 4. Verify arc did not lose contact with plate while cutting (hole cutting, scrap cutting, etc).
025 Primary 225 Secondary	Lost current Chopper 2 HPR260XD HPR400XD HPR800XD Only	Lost the current signal from Chopper 2 after transfer.	<ol style="list-style-type: none"> 1. Verify that the consumable parts are in good condition. 2. Verify proper cut-flow gas settings. 3. Verify pierce delay time. 4. Verify arc did not lose contact with plate while cutting (hole cutting, scrap cutting, etc).
026 Primary 226 Secondary	Lost transfer	Lost the transfer signal after transfer completed.	<ol style="list-style-type: none"> 1. Verify that the consumable parts are in good condition. 2. Verify proper cut-flow gas settings. 3. Verify pierce delay time. 4. Verify arc did not lose contact with plate while cutting (hole cutting, scrap cutting, etc). 5. Inspect work lead for damage or loose connections. 6. Try connecting work lead directly to the plate.
027 Primary 227 Secondary	Lost phase	Phase imbalance to chopper after contactor engaged or while cutting.	<ol style="list-style-type: none"> 1. Verify phase-to-phase voltage to power supply. 2. Disconnect power to power supply, remove cover on contactor and inspect contacts for excessive wear. 3. Inspect power cord, contactor, and input to chopper for loose connections. 4. Inspect phase loss fuses on Power Distribution board. Replace board if fuses are blown. 5. Perform phase loss test (see <i>Maintenance</i> section).
028 Primary 228 Secondary	Lost current Chopper 3 HPR400XD HPR800XD Only	Lost the current signal from Chopper 3 after transfer.	<ol style="list-style-type: none"> 1. Verify that the consumable parts are in good condition. 2. Verify proper cut-flow gas settings. 3. Verify pierce delay time. 4. Verify arc did not lose contact with plate while cutting (hole cutting, scrap cutting, etc).

Error code troubleshooting – error codes 030 to 042, 231 to 234

Error code number	Name	Description	Corrective action
030	Gas system error Auto Gas Only	A failure has occurred in the gas system.	<ol style="list-style-type: none"> 1. Verify that cable number 5 (power supply-to-gas console control cable) is not damaged and is properly connected to PCB3 and to the rear of the gas console. 2. Verify that cable number 6 (power supply-to-gas console power cable) is not damaged and is properly connected inside the power supply and to the rear of the gas console. 3. Verify that D18 (+5 VDC) and D17 (+3.3 VDC) are illuminated on PCB2 inside the gas console. These LEDs indicate power to PCB2. 4. If power is present at PCB2 and PCB3 and both gas console cables are good, then PCB2 or PCB3 has failed. Use the CAN tester to verify which board needs to be replaced.
031 Primary 231 Secondary	Start lost	Start signal was received and then lost before an arc was established.	<ol style="list-style-type: none"> 1. If a mechanical relay is being used to provide the HPR with a start signal, this relay is either bouncing when activated or the contacts are faulty. Replace the relay. 2. Inspect interface cable for damage; faulty crimps, or poor electrical connections. 3. If interface cable is good and a relay is not driving the start input, the CNC is dropping the start signal before a steady state arc has been established.
032	Hold timeout	Hold signal was active for longer than 60 seconds.	<ol style="list-style-type: none"> 1. Check the interface cable for damage. The hold wires may be short-circuiting inside. 2. The CNC is maintaining this input, it could be waiting for an IHS complete input from another torch. 3. If CNC interface cable is good and it is a 1-torch system, change PCB3.
033	Precharge time-out Auto Gas Only	Selection console was not able to charge the lines to the correct value.	This is a warning for a possible gas restriction in the leads. Verify that there are no restrictions in the plasma and shield hoses, or low inlet-gas pressure.
034 Primary 234 Secondary	Lost current Chopper 4 HPR400XD HPR800XD Only	Lost the current signal from Chopper 4 after transfer.	<ol style="list-style-type: none"> 1. Verify that the consumable parts are in good condition. 2. Verify proper cut-flow gas settings. 3. Verify pierce delay time. 4. Verify arc did not lose contact with plate while cutting (hole cutting, scrap cutting, etc).
042	Low nitrogen (N ₂) gas pressure	Nitrogen gas pressure under lower limit of: 2.07 bar (30 psi) – cutting 0.34 bar (5 psi) – marking During N ₂ purge, when changing between a fuel gas process and an oxidizer process.	<ol style="list-style-type: none"> 1. Verify that the nitrogen supply is turned on and inspect gas supply pressure and volume of gas remaining in supply tanks. 2. Verify that the gas regulator is set to 8.27 bar (120 psi). See <i>Setting the supply regulators (Installation section)</i>.

Error code troubleshooting – error codes 044 to 046

Error code number	Name	Description	Corrective action
044	Low plasma gas pressure	Plasma gas pressure under lower limit of 0.34 bar (5 psi) – preflow 3.45 bar (50 psi) – cutflow (cutting) 0.34 bar (5 psi) – cutflow (marking)	<ol style="list-style-type: none"> 1. Inspect gas supply pressure and volume of gas remaining in supply tanks. 2. Verify the gas regulator settings on gas console with the parameters in the cut charts. 3. See <i>Setting the supply regulators (Installation section)</i>. 4. Perform gas leak tests (<i>Maintenance section</i>).
045	High plasma gas pressure	Plasma gas pressure over upper limit of: 7.58 bar (110 psi) – manual 9.65 bar (140 psi) – auto	<ol style="list-style-type: none"> 1. Verify gas supply pressure settings. 2. Verify the gas regulator settings on gas console with cut chart. 3. See <i>Setting the supply regulators (Installation section)</i>. 4. Solenoid at off-valve is not opening. Verify power to valves, disconnect plasma and shield hoses exiting off-valve. If pressures decrease a valve is not functioning or no power to the valve.
046	Low line voltage	Line voltage is close to or less than the lower limit of 102 VAC (120 VAC -15%). The normal lower limit for operation is 108 VAC (120 VAC -10%).	<ol style="list-style-type: none"> 1. Verify input-line voltage at PCB2 in the power supply (also PCB1 in the chiller-interface console for HPR800XD systems). Voltage needs to be within 10% of nominal (120 VAC). 2. Verify fuses on PCB2 in the power supply. 3. Verify 120 VAC voltage at plug J2.4, pins 3 and 4 on PCB2 in the power supply. 4. For HPR800XD systems, verify the voltage on PCB1 in the chiller-interface console with a DC volt meter. It should be about 0.415 VDC between TP23 and TP2 on PCB1 in the chiller-interface console. 5. If AC voltage on PCB2 in the power supply, J2.4, pins 3 and 4, is greater than 108 VAC and DC voltage between TP23 and TP2 on PCB1 in the chiller-interface console is less than 0.38 VDC, verify minimum 108 VAC voltage at plug J1.4, pins 1 and 2 on PCB1 in the chiller-interface console. Verify the wiring between PCB2 in the power supply and J1.4 on PCB1 in the chiller-interface console. If the voltage at plug J1.4 is greater than 108 VAC, but the DC voltage on TP23 and TP2 is less than 0.38, replace PCB1 in the chiller-interface console. 6. If the AC voltage on PCB2 in the power supply at J2.4, pins 3 and 4, is greater than 108 VAC and the DC voltage between TP23 and TP2 on PCB1 in the chiller-interface console (HPR800XD only) is also greater than 0.38 VDC, verify the CAN link between PCB3 in the power supply and PCB1 in the chiller-interface console.

Error code troubleshooting – error codes 047 to 053, 248 to 250

Error code number	Name	Description	Corrective action
047	High line voltage	Line voltage is close to or greater than the upper limit of 138 VAC (120 VAC +15%). The normal upper limit for operation is 132 VAC (120 VAC +10%).	<ol style="list-style-type: none"> 1. Verify input–line voltage at PCB2 in the power supply (also PCB1 in the chiller-interface console for HPR800XD systems). Voltage needs to be within 10% of nominal (120 VAC). 2. Verify fuses on PCB2 in the power supply. 3. Verify 120 VAC voltage at plug J2.4, pins 3 and 4 on PCB2 in the power supply. 4. For HPR800XD systems, verify the voltage on PCB1 in the chiller-interface console with a DC volt meter. It should be about 0.415 VDC between TP23 and TP2 on PCB1 in the chiller-interface console. 5. If AC voltage on PCB2 in the power supply, J2.4, pins 3 and 4, is less than 132 VAC and DC voltage between TP23 and TP2 on PCB1 in the chiller-interface console is greater than 0.44 VDC, verify maximum 132 VAC voltage at plug J1.4, pins 1 and 2 on PCB1 in the chiller-interface console. Verify wiring between PCB2 in the power supply and J1.4 on PCB1 in the chiller-interface console. If the voltage at plug J1.4 is less than 132 VAC, but the DC voltage on TP23 and TP2 is greater than 0.44, replace PCB1 in the chiller-interface console. 6. If the AC voltage on PCB2 in the power supply at J2.4, pins 3 and 4, is less than 132 VAC and the DC voltage between TP23 and TP2 on PCB1 in the chiller-interface console (HPR800XD only) is also less than 0.44 VDC, verify the CAN link between PCB3 in the power supply and PCB1 in the chiller-interface console.
048 Primary 248 Secondary	CAN error	An error occurred with the CAN communications between the power supply and the gas console.	<ol style="list-style-type: none"> 1. Verify that cable number 5 (power supply-to-gas console control cable) is not damaged and is properly connected to PCB3 and to the rear of the gas console. 2. Verify that cable number 6 (power supply-to-gas console power cable) is not damaged and is properly connected inside the power supply and to the rear of the gas console. 3a. (Manual gas console) Verify that D14 (+5 VDC) and D19 (+3.3 VDC) are illuminated on PCB2 inside the gas console. These LEDs indicate power to PCB2. 3b. (Auto gas console) Verify that D18 (+5 VDC) and D17 (+3.3 VDC) are illuminated on PCB2 inside the gas console. These LEDs indicate power to PCB2. 4. If power is present at PCB2 and PCB3 and both gas console cables are good, then PCB2 or PCB3 has failed. Use the CAN tester to verify which board needs to be replaced.
050 Primary 250 Secondary	Start signal is on at power-up	Plasma start signal input is active during power-up of power supply.	<ol style="list-style-type: none"> 1. Stop or clear the cutting program. The plasma start signal to the plasma was not dropped after the last cut. 2. Verify that the CNC interface cable is not damaged. 3. Remove CNC interface cable from PCB3 and look for an open circuit between pins 15 and 34. 4. If the circuit is closed either the CNC is issuing a plasma start or the CNC interface cable is damaged. 5. If circuit is open, and LEDN300J is illuminated with CNC Interface cable removed from PCB3, replace PCB3.
053	Low shield gas pressure	Shield pressure is below lower limit of 0.14 bar (2 psi).	<ol style="list-style-type: none"> 1. Verify gas supply pressure and that a sufficient volume of gas remains in your supply. 2. Verify gas regulator settings on gas console with cut chart. 3. See <i>Setting the supply regulators</i> (Installation section). 4. Perform gas leak tests (Maintenance section).

Error code troubleshooting – error codes 054 to 061

Error code number	Name	Description	Corrective action
054	High shield gas pressure	Shield gas pressure is over upper limit of: 7.58 bar (110 psi) – manual 9.65 bar (140 psi) – auto	<ol style="list-style-type: none"> 1. Verify gas supply regulator settings. See <i>Setting the supply regulators</i> (Installation section). 2. Verify pressure settings on gas console with cut chart. 3. Solenoid at off-valve is not opening. Verify power to valves, disconnect plasma and shield hoses exiting off-valve. If pressures decrease, a valve is not functioning or no power to the valve.
055	MV1 inlet pressure Auto Gas Only	Motor valve 1 inlet pressure is less than 3.45 bar (50 psi) or greater than 9.65 bar (140 psi).	<ol style="list-style-type: none"> 1. Verify that gas pressure transducer P1 is between 3.45 bar (50 psi) and 9.65 bar (140 psi). Increase or decrease the inlet gas pressure to correct the problem.
056	MV2 inlet pressure Auto Gas Only	Motor valve 2 inlet pressure is less than 3.45 bar (50 psi) or greater than 9.65 bar (140 psi).	<ol style="list-style-type: none"> 1. Verify that gas pressure transducer P2 is between 3.45 bar (50 psi) and 9.65 bar (140 psi). Increase or decrease the inlet gas pressure to correct the problem.
057	Cut gas 1 pressure Auto Gas Only	Cut gas 1 outlet pressure is less than 3.45 bar (50 psi) or greater than 9.65 bar (140 psi) in the selection console.	<ol style="list-style-type: none"> 1. Verify that gas pressure transducer P3 is between 3.45 bar (50 psi) and 9.65 bar (140 psi). Increase or decrease the inlet gas pressure to correct the problem.
058	Cut gas 2 pressure Auto Gas Only	Cut gas 2 outlet pressure of O2, air, N2 or Ar plasma gas processes is less than 3.45 bar (50 psi) or greater than 9.65 bar (140 psi). For H5, H35, H35-N2, or F5 plasma gas processes, the cut gas 2 outlet pressure is less than 1.38 bar (20 psi) or greater than 9.65 Bar (140 psi).	<ol style="list-style-type: none"> 1. For O2, air, N2, or Ar plasma gas processes: Verify that gas pressure transducer P4 is between 3.45 bar (50 psi) and 9.65 bar (140 psi). Increase or decrease the inlet gas pressure to correct the problem. 2. For H5, H35, H35-N2, or F5 plasma gas processes: Verify that gas pressure transducer P4 is between 1.38 bar (20 psi) and 9.65 bar (140 psi). Increase or decrease the inlet gas pressure to correct the problem.
060	Low coolant flow	Coolant flow is less than the required 2.3 lpm (0.6 gpm).	<ol style="list-style-type: none"> 1. Verify that the correct consumables are properly installed. 2. Perform the coolant flow test procedure in the Maintenance section of the manual.
061	No plasma gas type	<p>Manual gas - The gas console control board is not receiving signals from the gas selector knob.</p> <p>Auto gas - The selection console is not receiving the plasma gas type signal.</p>	<ol style="list-style-type: none"> 1. Auto gas - the process parameters may not have been downloaded. Verify that the process information can be viewed on the CNC screen. 2. Manual gas - the selector knob (2) may be set between positions. Reset the knob. 3. Verify that there is power to the console by looking to see if any LED on any board in the selection console (auto) or gas console (manual) is illuminated. If no LED is illuminated, verify that the fuse on the power distribution PCB is in proper working condition. 4. If the problem still exists, replace the control board.

Error code troubleshooting – error codes 062 to 067, 265 to 267

Error code number	Name	Description	Corrective action
062	No shield gas type	Manual gas – The gas console control board is not receiving signals from the gas selector knob. Auto gas – The selection console is not receiving the shield gas type signal.	<ol style="list-style-type: none"> 1. Auto gas – The process parameters may not have been downloaded. Verify that the process information can be viewed on the CNC screen. 2. Manual gas – The selector knob (2) may be set between positions. Reset the knob. 3. Verify that there is power to the console by looking to see if any LED on any board in the selection console (auto) or gas console (manual) is illuminated. If no LEDs are illuminated, verify that the fuse on the power distribution PCB is in proper working condition. 4. If the problem still exists, replace the control board.
065 Primary 265 Secondary	Chopper 1 overtemp	Chopper 1 has overheated.	<ol style="list-style-type: none"> 1. Verify that all chopper fans are operating properly. Spinning fan blades should be difficult to see. 2. Blow dust out of system, especially from fans and heat sink of chopper. 3. Verify that the voltage on rear side of J3.202, pins 2 and 3 on PCB3, is less than or equal to 2.9 VDC. 4. If the voltage is low, verify correct wiring between chopper temperature sensor and J3.202 pins 1 and 2. 5. If wiring is good and overtemp error does not clear after 30 minutes of the power supply idling with the fans running, replace the chopper.
066 Primary 266 Secondary	Chopper 2 overtemp	Chopper 2 has overheated.	<ol style="list-style-type: none"> 1. Verify that all chopper fans are operating properly. Spinning fan blades should be difficult to see. 2. Blow dust out of system, especially from fans and heat sink of chopper. 3. Verify that the voltage on rear side of J3.202, pins 5 and 6 on PCB3, is less than or equal to 2.9 VDC. 4. If the voltage is low, verify correct wiring between chopper temperature sensor and J3.202 pins 4 and 5. 5. If wiring is good and overtemp error does not clear after 30 minutes of the power supply idling with the fans running, replace the chopper.
067 Primary 267 Secondary	Magnetics overtemp	Power transformer has overheated.	<ol style="list-style-type: none"> 1. Verify that all the large fans are operating properly. Spinning fan blades should be difficult to see. 2. Blow dust out of system especially from fans and large power transformer. 3. Verify that the voltage on the rear side of J3.202 pins 14 and 15, is equal to or less than 3.2 VDC. 4. If voltage is low or near 0 VDC, inspect wiring between the transformer's temperature sensor and J3.202 pins 13 and 14. Look for shorts between wires or to ground. 5. If wiring is good, the transformer has overheated. Allow the power supply to idle with the fans running for a minimum of 30 minutes to cool the large power transformer. 6. Replace the transformer's temperature sensor if it is open or shorted. Replacement kit part number is 228309.

Error code troubleshooting – error codes 071 to 075, 273 to 275

Error code number	Name	Description	Corrective action
071	Coolant overtemp	Torch coolant has overheated.	<ol style="list-style-type: none"> 1. Verify that the large fan in the cooler (HPR400XD only) is running. 2. Blow dust out of the cooler (HPR400XD only), especially from the heat exchanger. 3. Verify that the voltage on the rear side of J1.5 pins 6 and 8, is equal to or lower than 2.8 VDC. 4. If voltage is low, inspect wiring between coolant temperature sensor and J1.5, pins 5 and 6, for shorts to wires or ground. 5. If wiring is good, the coolant has overheated; let system idle with the fans running for 30 minutes to cool. 6. Replace the coolant temperature sensor if it is open or shorted. Sensor part number is 229224.
072	Auto gas, control board overtemp or failure Auto Gas Only	Control board has exceeded 90° C (194° F). If the control board is not over 90° C (194° F), the control board has failed.	<ol style="list-style-type: none"> 1. Verify that the airflow to the gas console is not restricted. 2. Replace PCB2 in the metering console. 3. Replace PCB2 in the selection console.
073 Primary 273 Secondary	Chopper 3 overtemp HPR400XD HPR800XD Only	Chopper 3 has overheated.	<ol style="list-style-type: none"> 1. Verify that all chopper fans are operating properly. Spinning fan blades should be difficult to see. 2. Blow dust out of system, especially from fans and heat sink of chopper. 3. Verify that the voltage on rear side of J3.202, pins 8 and 9 on PCB3, is less than or equal to 2.9 VDC. 4. If the voltage is low, verify correct wiring between chopper temperature sensor and J3.202 pins 7 and 8. 5. If wiring is good and overtemp error does not clear after 30 minutes of the power supply idling with the fans running, replace the chopper.
074 Primary 274 Secondary	Chopper 4 overtemp HPR400XD HPR800XD Only	Chopper 4 has overheated.	<ol style="list-style-type: none"> 1. Verify that all chopper fans are operating properly. Spinning fan blades should be difficult to see. 2. Blow dust out of system, especially from fans and heat sink of chopper. 3. Verify that the voltage on rear side of J3.202, pins 11 and 12 on PCB3, is less than or equal to 2.9 VDC. 4. If the voltage is low, verify correct wiring between chopper temperature sensor and J3.202 pins 10 and 11. 5. If wiring is good and overtemp error does not clear after 30 minutes of the power supply idling with the fans running, replace the chopper.
075 Primary 275 Secondary	Low current on CS3 HPR400XD HPR800XD Only	A current less than 10 amps has been detected by current sensor 3.	See the chopper test later in this section.

Error code troubleshooting – error codes 076 to 101, 276 to 301

Error code number	Name	Description	Corrective action
076 Primary 276 Secondary	Low current on CS4 HPR400XD HPR800XD Only	A current less than 10 amps has been detected by current sensor 4.	See the chopper test later in this section.
093	No coolant flow	Coolant flow signal was lost or never was satisfied.	<ol style="list-style-type: none"> 1. If this is a new system, follow start procedure. 2. Verify that the coolant filter is in good condition. 3. Perform coolant flow tests (<i>Maintenance</i> section). 4. Verify that the CNC drives the plasma start signal for at least 10 seconds to allow the timed-out pump to turn on again.
095 Primary 295 Secondary	High current on CS4 HPR400XD Only	A current greater than 35 amps has been detected by current sensor 4.	See the chopper test later in this section.
098	Phase loss at initialization HPR400XD HPR800XD Only	The system detected incoming line voltage during power-up, before the contactor was energized.	<ol style="list-style-type: none"> 1. Verify phase-to-phase voltage to power supply. 2. Disconnect power to power supply, remove cover on contactor and inspect contacts for excessive wear. 3. Inspect power cord, contactor, and input to chopper for loose connections. 4. Inspect phase loss fuses on Power Distribution board. Replace board if fuses are blown. 5. Perform phase loss test (see <i>Maintenance</i> section).
099 Primary 299 Secondary	Chopper 1 overtemp at power-up	Chopper 1 is indicating an overtemp at power-up.	<ol style="list-style-type: none"> 1. Verify that the temperature sensor for the chopper has not been bypassed or that the wires to the temperature switch are shorted out in the harness, or that the sensor is open. 2. If no jumper is present, the chopper is overheated and needs time to cool to 83° C (181.4° F).
100 Primary 300 Secondary	Chopper 2 overtemp at power-up	Chopper 2 is indicating an overtemp at power-up.	<ol style="list-style-type: none"> 1. Verify that the temperature sensor for the chopper has not been bypassed or that the wires to the temperature switch are shorted out in the harness, or that the sensor is open. 2. If no jumper is present, the chopper is overheated and needs time to cool to 83° C (181.4° F).
101 Primary 301 Secondary	Magnetics overtemp at power-up	Main transformer is indicating an overtemp at power-up.	<ol style="list-style-type: none"> 1. Verify that the transformer temperature sensor has not been bypassed or the wires to the temperature sensor are not shorted out in the harness. 2. Verify that the sensor is not open or shorted, if it is not open or shorted, the main transformer is overheated and needs time to cool to 150° C (302° F).

Error code troubleshooting – error codes 102 to 111, 302 to 308

Error code number	Name	Description	Corrective action
102 Primary 302 Secondary	Chopper 1 current at power-up	Chopper 1 current signal is active at power-up.	See wiring diagrams in section 7 1. Verify that the voltage at CS1 is correct. 2. Verify that the wiring between CS1 and PCB3 is correct and not damaged. 3. Swap CS1 with CS2. If the error code changes to 156, replace the original CS1.
103 Primary 303 Secondary	High current on CS1	A current greater than 35 Amps has been detected by current sensor 1.	See the chopper test later in this section.
104 Primary 304 Secondary	High current on CS2	A current greater than 35 amps has been detected by current sensor 2.	See the chopper test later in this section.
105 Primary 305 Secondary	Low current on CS1	A current less than 10 amps has been detected by current sensor 1.	See the chopper test later in this section.
106 Primary 306 Secondary	Low current on CS2	A current less than 10 amps has been detected by current sensor 2.	See the chopper test later in this section.
107 Primary 307 Secondary	High current on CS3 HPR400XD HPR800XD Only	A current greater than 35 amps has been detected by current sensor 3.	See the chopper test later in this section.
108 Primary 308 Secondary	Transfer at power-up	The system has detected current on the work lead during power-up.	1. Verify that the electrical connections to current sensors CS1 and CS3 are correct and not damaged. 2. Replace PCB3 if connections are correct and not damaged. 3. Verify that the main contactor (CON1) is not welded closed, or closing at power-up.
109	Coolant flow at power-up	“Coolant flow OK” signal is active during power-up and before pump motor is activated.	Either the coolant flow sensor was bypassed or it is faulty. 1. Verify that there is power at the sensor. 2. Verify that all the connectors have good connections.
111	Coolant overtemp at power-up	Coolant is indicating an overtemp at power-up.	1. Verify that the coolant temperature sensor has not been bypassed or the wires to the sensor are not shorted out in the harness. 2. If not, the coolant temperature is over the set point and needs time to cool to 70° C (158° F).

Error code troubleshooting – error codes 116 to 133, 316

Error code number	Name	Description	Corrective action
116 Primary 316 Secondary	Watchdog interlock	An error occurred with the CAN communication system.	<ol style="list-style-type: none"> 1. Verify that cable number 5 (power supply-to-gas console control cable) is not damaged and is properly connected to PCB3 and the rear of the gas console. 2. Verify that cable number 6 (power supply-to-gas console power cable) is not damaged and is properly connected inside the power supply and to the rear of the gas console. 3a. (Manual gas console) Verify that D14 (+5 VDC) and D19 (+3.3 VDC) are illuminated on PCB2 inside the gas console. These LEDs indicate power to PCB2. 3b. (Auto gas console) Verify that D18 (+5 VDC) and D17 (+3.3 VDC) are illuminated on PCB2 inside the gas console. These LEDs indicate power to PCB2. 4. If power is present at PCB2 and PCB3 and both gas console cables are good, then PCB2 or PCB3 has failed. Use the CAN tester to verify which board needs to be replaced. 5. Verify that the gas console control PCB and power distribution PCBs are securely mounted to the chassis at all four corners.
123	MV1 error Auto Gas Only	Motor valve 1 did not move into position within 60 seconds.	Verify that LED D17 or D18 illuminates on the AC valve driver PCB in the selection console. If either illuminates, replace the motor valve. If they do not illuminate, replace PCB3.
124	MV2 error Auto Gas Only	Motor valve 2 did not move into position within 60 seconds.	Verify that LED D19 or D20 is illuminating on the AC valve driver PCB in the selection console. If either illuminates, replace the motor valve. If they do not illuminate, replace PCB3.
133	Unknown gas console type	The power supply control board does not recognize the gas console that is installed or has not received a CAN message.	<ol style="list-style-type: none"> 1. Verify that the part numbers of PCB2 and PCB3 are correct. 2. Verify that the power supply-to-gas console control cable is not damaged and is properly connected to PCB3 and the rear of the gas console. 3. Verify that the power supply-to-gas console power cable is not damaged and is properly connected inside the power supply and to the rear of the gas console. 4. Verify that D18 (+5 VDC) and D17 (+3.3 VDC) are illuminated on PCB2 inside the gas console. These LEDs indicate power to PCB2. 5. If power is present at PCB2 and PCB3 and both gas console cables are good, then PCB2 or PCB3 has failed. Use the CAN tester to verify which board needs to be replaced.

Error code troubleshooting – error codes 134 to 140, 334 and 338

Error code number	Name	Description	Corrective action
134 Primary 334 Secondary	Chopper 1 overcurrent	Chopper 1 current feedback has exceeded 160 amps.	<ol style="list-style-type: none"> 1. Verify that the wiring between CS1 and PCB3 is correct and not damaged. 2. Measure voltage across current sensor. <ol style="list-style-type: none"> a) Red to black = +15 VDC, Green to black = -15 VDC, white to black = 0 VDC at idle and varies with current output (4 VDC = 100 amps). b) If possible, take a voltage reading on current sensor while trying to cut. Ratio is 4 VDC = 100 amps. c) If the current sensor voltage is approximately 6.4 VDC or greater at idle, replace the current sensor. 3. Remove connector JA.1 from the chopper and verify that LED1 is extinguished. <ol style="list-style-type: none"> a) If LED1 is extinguished with the connector removed, then reconnect JA.1 and try to fire the torch. If the chopper still goes into overcurrent, replace the chopper. b) If the chopper does not go into overcurrent, replace PCB3.
138 Primary 338 Secondary	Chopper 2 overcurrent HPR260XD HPR400XD HPR800XD Only	Chopper 2 current feedback has exceeded 160 amps.	<ol style="list-style-type: none"> 1. Verify that the wiring between CS2 and PCB3 is correct and not damaged. 2. Measure voltage across current sensor. <ol style="list-style-type: none"> a) Red to black = +15 VDC, Green to black = -15 VDC, white to black = 0 VDC at idle and varies with current output (4 VDC = 100 amps). b) If possible, take a voltage reading on current sensor while trying to cut. Ratio is 4 VDC = 100 amps. c) If the current sensor voltage is approximately 6.4 VDC or greater at idle, replace the current sensor. 3. Remove connector JB.1 from the chopper and verify that LED1 is extinguished. <ol style="list-style-type: none"> a) If LED1 is extinguished with the connector removed, then reconnect JB.1 and try to fire the torch. If the chopper still goes into overcurrent, replace the chopper. b) If the chopper does not go into overcurrent, replace PCB3.
139	Purge time-out error	The purge cycle did not complete within 3 minutes.	<p>This is a warning for a possible gas restriction in the leads.</p> <ol style="list-style-type: none"> 1. Verify that there are no restrictions in the plasma and shield hoses. 2. Verify that the inlet gas pressures are set to the proper levels.
140	Pressure transducer 1 or 8 error Auto Gas Only	Faulty transducer or control board in the metering console or the selection console.	<ol style="list-style-type: none"> 1. Verify that transducer P1 in the selection console is working properly. Replace if necessary. 2. Verify that transducer P8 in the metering console is working properly. Replace if necessary. 3. Verify that the control boards in the metering and selection consoles are working properly. Replace if necessary.

Error code troubleshooting – error codes 141 to 152, 346 to 351

Error code number	Name	Description	Corrective action
141	Pressure transducer 2 or 7 error Auto Gas Only	Faulty transducer or control board in the metering console or the selection console.	<ol style="list-style-type: none"> 1. Verify that transducer P2 in the selection console is working properly. Replace if necessary. 2. Verify that transducer P7 in the metering console is working properly. Replace if necessary. 3. Verify that the control boards in the metering and selection consoles are working properly. Replace if necessary.
142	Pressure transducer 3 or 5 error Auto Gas Only	Faulty transducer or control board in the metering console or the selection console.	<ol style="list-style-type: none"> 1. Verify that transducer P3 in the selection console is working properly. Replace if necessary. 2. Verify that transducer P5 in the metering console is working properly. Replace if necessary. 3. Verify that the control boards in the metering and selection consoles are working properly. Replace if necessary.
143	Pressure transducer 4 or 6 error Auto Gas Only	Faulty transducer or control board in the metering console or the selection console.	<ol style="list-style-type: none"> 1. Verify that transducer P4 in the selection console is working properly. Replace if necessary. 2. Verify that transducer P6 in the metering console is working properly. Replace if necessary. 3. Verify that the control boards in the metering and selection consoles are working properly. Replace if necessary.
144	Internal flash error Manual Gas Only	Communication problem to the flash chip on the gas console control board.	Replace the control board.
145	Internal flash error Auto Gas Only	Communication problem to the flash chip on the selection console control board.	Replace the control board.
146 Primary 346 Secondary	Chopper 3 overtemp at power-up HPR400XD HPR800XD Only	Chopper 3 is indicating an overtemp at power-up.	<ol style="list-style-type: none"> 1. Verify that the temperature sensor for the chopper has not been bypassed or that the wires to the temperature switch are shorted out in the harness, or that the sensor is open. 2. If no jumper is present, the chopper is overheated and needs time to cool to 83° C (181.4° F).
147 Primary 347 Secondary	Chopper 4 overtemp at power-up HPR400XD HPR800XD Only	Chopper 4 is indicating an overtemp at power-up.	<ol style="list-style-type: none"> 1. Verify that the temperature sensor for the chopper has not been bypassed or that the wires to the temperature switch are shorted out in the harness, or that the sensor is open. 2. If no jumper is present, the chopper is overheated and needs time to cool to 83° C (181.4° F).
151 Primary 351 Secondary	Software fail	Software has detected an incorrect state or condition.	Replace power supply control board.
152	Internal flash error	Communication problem to the flash chip on the power supply control board.	Replace the control board.

Error code troubleshooting – error codes 153 to 156, 354 to 356

Error code number	Name	Description	Corrective action
153	PS EEPROM error	EEPROM memory on power supply control board not working.	Replace the control board.
154 Primary 354 Secondary	Chopper 3 overcurrent HPR400XD HPR800XD Only	Chopper 3 current feedback has exceeded 160 amps.	<ol style="list-style-type: none"> 1. Verify that the wiring between CS3 and PCB3 is correct and not damaged. 2. Measure voltage across current sensor. <ol style="list-style-type: none"> a) Red to black = +15 VDC, Green to black = -15 VDC, white to black = 0 VDC at idle and varies with current output (4 VDC = 100 amps). b) If possible, take a voltage reading on current sensor while trying to cut. Ratio is 4 VDC = 100 amps. c) If the current sensor voltage is approximately 6.4 VDC or greater at idle, replace the current sensor. 3. Remove connector JC.1 from the chopper and verify that LED1 is extinguished. <ol style="list-style-type: none"> a) If LED1 is extinguished with the connector removed, then reconnect JC.1 and try to fire the torch. If the chopper still goes into overcurrent, replace the chopper. b) If the chopper does not go into overcurrent, replace PCB3..
155 Primary 355 Secondary	Chopper 4 overcurrent HPR400XD HPR800XD Only	Chopper 4 current feedback has exceeded 160 amps.	<ol style="list-style-type: none"> 1. Verify that the wiring between CS4 and PCB3 is correct and not damaged. 2. Measure voltage across current sensor. <ol style="list-style-type: none"> a) Red to black = +15 VDC, Green to black = -15 VDC, white to black = 0 VDC at idle and varies with current output (4 VDC = 100 amps). b) If possible, take a voltage reading on current sensor while trying to cut. Ratio is 4 VDC = 100 amps. c) If the current sensor voltage is approximately 6.4 VDC or greater at idle, replace the current sensor. 3. Remove connector JD.1 from the chopper and verify that LED1 is extinguished. <ol style="list-style-type: none"> a) If LED1 is extinguished with the connector removed, then reconnect JD.1 and try to fire the torch. If the chopper still goes into overcurrent, replace the chopper. b) If the chopper does not go into overcurrent, replace PCB3.
156 Primary 356 Secondary	Chopper 2 current at power-up HPR260XD HPR400XD HPR800XD Only	Chopper 2 current signal is active at power-up.	<p>See wiring diagrams in section 7</p> <ol style="list-style-type: none"> 1. Verify that the voltage at CS2 is correct. 2. Verify that the wiring between CS2 and PCB3 is correct and not damaged. 3. Swap CS2 with CS3. If the error code changes to 157, replace the original CS2.

Error code troubleshooting – error codes 157 to 159, 357 to 359

Error code number	Name	Description	Corrective action
157 Primary 357 Secondary	Chopper 3 current at power-up HPR400XD HPR800XD Only	Chopper 3 current signal is active at power-up.	See wiring diagrams in section 7 1. Verify that the voltage at CS3 is correct. 2. Verify that the wiring between CS3 and PCB3 is correct and not damaged. 3. Swap CS3 with CS2. If the error code changes to 156, replace the original CS3.
158 Primary 358 Secondary	Chopper 4 current at power-up HPR400XD HPR800XD Only	Chopper 4 current signal is active at power-up.	See wiring diagrams in section 7 1. Verify that the voltage at CS4 is correct. 2. Verify that the wiring between CS4 and PCB3 is correct and not damaged. 3. Swap CS4 with CS2. If the error code changes to 156, replace the original CS4.
159 Primary 359 Secondary	Motor-drive fault HPR400XD and HPR800XD	The pump-motor-drive board (PCB7) is indicating a drive fault. Note: The secondary error code (359) may display if the secondary power supply is turned off individually, or when the entire system is turned off. Customers with a manual gas console will not see this error code when the entire system is turned off.	1. Verify that the circuit breaker on PCB7 has not tripped. If it has tripped, reset the breaker by pressing the button until it is even with the top of the circuit breaker. If the circuit breaker is not tripped and there is no power to PCB7, verify that the fuse on PCB2 in the power supply is good. 2. If D32 on PCB7 illuminates, the solenoid valve and motor are drawing too much current. D32 will only illuminate for a short time, and extinguishes after the outputs from the pump-motor-drive turn-off in response to the fault condition. Verify the wiring to the solenoid valve and the motor. Verify that the pump spins freely and is properly mounted to the motor. Look for obstructions in the torch, consumables, coolant lines, and in-line filter. Verify that the solenoid valve is operating. Any of these can cause the motor or solenoid valve to draw excessive current. Test for low coolant flow by using the coolant flow test in this section. 3. If D32 on PCB7 illuminates immediately at power-up, and all the items above have been verified, replace PCB7. 4. If D30 on PCB7 illuminates, the IGBT drive has encountered an over current condition. D30 will only illuminate for a short time, and extinguishes after the outputs from the pump motor-drive turn off. Follow the same steps for D32 above. 5. If D31 on PCB7 illuminates, the heatsink thermistor is indicating that the heatsink is too hot. Wait 10 minutes for it to cool. If the error remains, verify that the wires from heatsink on PCB7 are properly connected to the J6 connector on PCB7. If the error still remains, turn OFF all power to the system and measure the resistance on the J6 connector between pins 1 and 2. At 25° C (77° F) the resistance should be 10k.

Error code troubleshooting – error codes 160 to 180

Error code number	Name	Description	Corrective action
160	HPR cooler's CAN fault HPR400XD Only	Communication between the control board (PCB3 in the power supply) and the cooler sensor board (PCB1 in the cooler) was interrupted for more than 1 second.	<ol style="list-style-type: none"> 1. Verify that the cable connections from the power supply to the cooler are good. 2. Verify that D1 (+ 5 VDC) and D2 (+3.3 VDC) are illuminated on PCB1 inside the cooler. 3. Verify that the CAN bus LEDs, D7 and D8 are blinking.
161	Maximum coolant flow has been exceeded	Coolant flow has exceeded 6.8 lpm (1.8 gpm) for a cooler, 8.52 lpm (2.25 gpm) for a chiller.	<ol style="list-style-type: none"> 1. Verify proper coolant flow. 2. Look for air bubbles in the coolant. 3. Verify that the coolant is mixed in the proper proportions.
180	Selection console CAN time-out Auto Gas Only	The power supply did not receive a CAN message from the selection console within 1 second.	<ol style="list-style-type: none"> 1. Verify that the power supply-to-selection console CONTROL and POWER cables are not damaged and are properly connected to PCB3, and the rear of the selection console. 2. Verify that D17 (+5 VDC) and D18 (+3.3 VDC) are illuminated on PCB2 inside the selection console. These LEDs indicate power to PCB2. Also verify that D26 (CAN – RX) and D27 (CAN – TX) are illuminated on PCB2 inside the selection console. These LEDs indicate communication between the selection console and the power supply. 3. If power is present at PCB2 and PCB3 and both selection console cables are good, then PCB2 or PCB3 has failed. Use the CAN tester to verify which board needs to be replaced. 4. Verify that the gas console control PCB and power distribution PCBs are securely mounted to the chassis at all four corners.

Error code troubleshooting – error code 181, 182, 298, and 383

Error code number	Name	Description	Corrective action
181	Metering console CAN time-out Auto Gas Only	The power supply did not receive a CAN message from the metering console within 1 second.	<ol style="list-style-type: none"> 1. Verify that the power supply-to-metering console CONTROL and POWER cables are not damaged and are properly connected to PCB3, and the rear of the metering console. 2. Verify that D17 (+5 VDC) and D18 (+3.3 VDC) are illuminated on PCB2 inside the metering console. These LEDs indicate power to PCB2. Also verify that D26 (CAN – RX) and D27 (CAN – TX) are illuminated on PCB2 inside the metering console. These LEDs indicate communication between the metering console and the power supply. 3. If power is present at PCB2 and PCB3 and both metering console cables are good, then PCB2 or PCB3 has failed. Use the CAN tester to verify which board needs to be replaced. 4. Verify that the gas console control PCB and power distribution PCBs are securely mounted to the chassis at all four corners.
182	Secondary power supply time-out HPR400XD HPR800XD Only	The secondary power supply fails before transmitting the error to the primary power supply.	<ol style="list-style-type: none"> 1. The primary power supply to secondary power supply CAN communication cable was disconnected after power-up. 2. The cable has electrical interference (noise) or the cable shielding has been compromised.
298	Secondary power supply phase loss at initialization HPR800XD Only	The system detected incoming line voltage during power-up, before the contactor was energized.	<ol style="list-style-type: none"> 1. Verify phase-to-phase voltage to power supply. 2. Disconnect power to power supply, remove cover on contactor and inspect contacts for excessive wear. 3. Inspect power cord, contactor, and input to chopper for loose connections. 4. Inspect phase loss fuses on Power Distribution board. Replace board if fuses are blown. 5. Perform phase loss test (see <i>Maintenance</i> section).
383	No ramp-up message HPR400XD HPR800XD Only	The secondary power supply is ready to provide current output but does not receive the control signal from the primary power supply.	<ol style="list-style-type: none"> 1 Turn off the power to the system and then turn on the power again. 2. The cable has electrical interference (noise) or the cable shielding has been compromised.

Power supply states

Power supply states are displayed on the CNC screen. The diagnostic screen shown below is for reference.

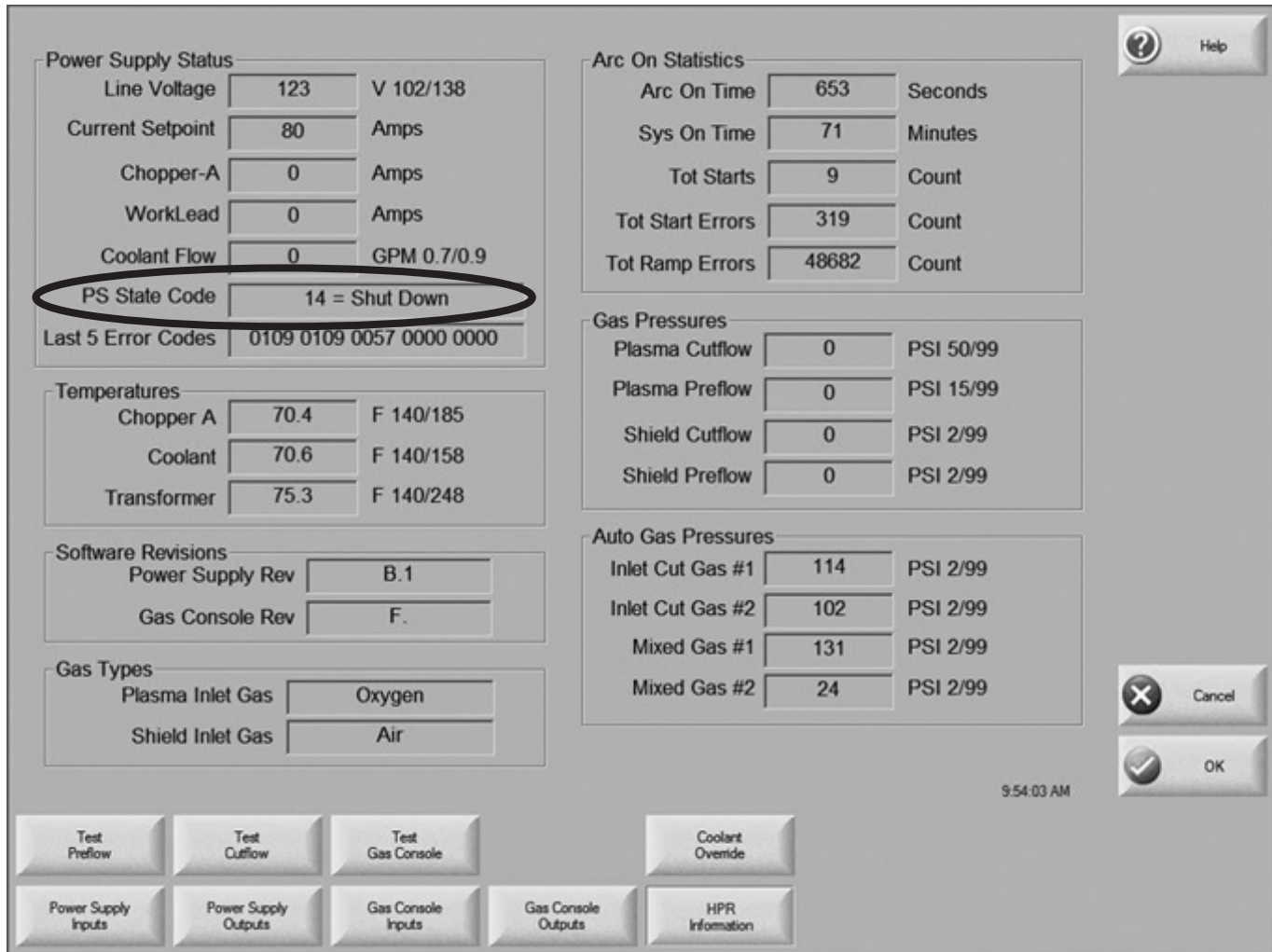

State code	Name	State code	Name
00	Power-up (idle)	11	Cycle complete (auto off)
02	Purge	12	Test cutflow
03	Ready for start (idle 2)	14	Shutdown
04	Preflow	15	Reset
05	Pilot arc	16	Maintenance
06	Transfer	20	Test preflow
07	Ramp-up	22	Manual pump control
08	Steady state	23	Inlet leak check
09	Ramp-down	24	System leak check
10	Final ramp-down	25	Burkert valve flow check

Plasma system operation with pump time-out

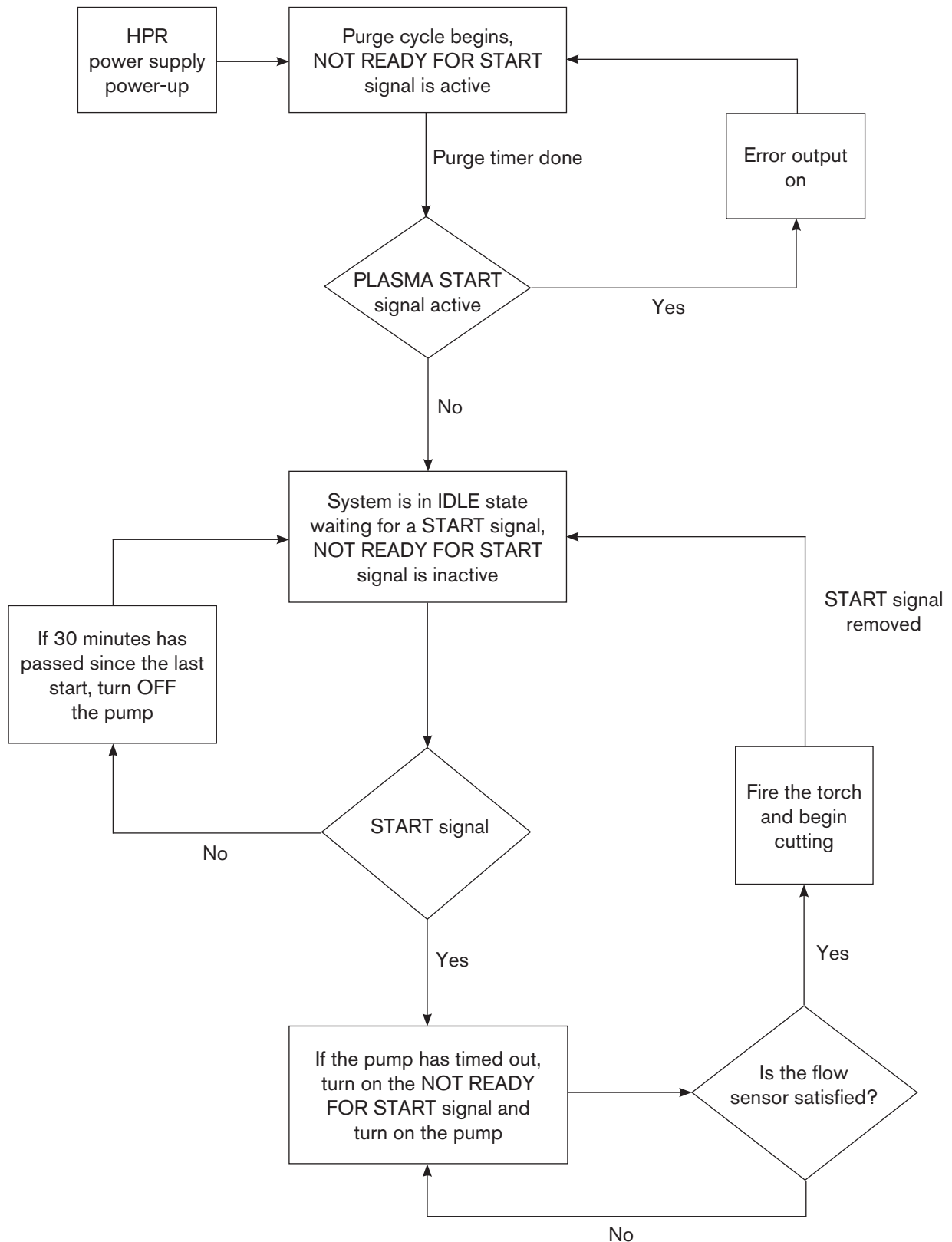

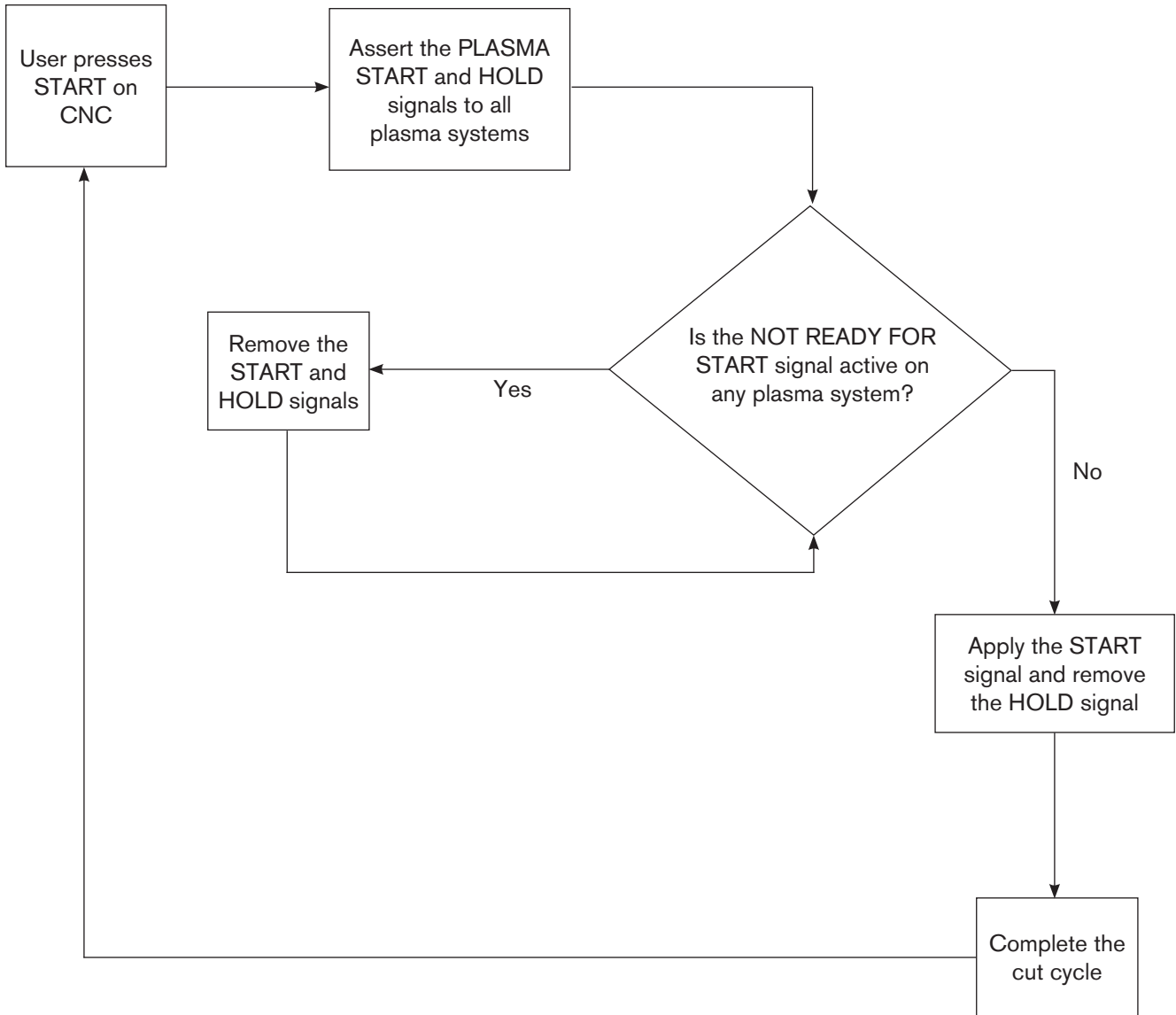

CNC operation with pump time-out



Initial checks

Before trouble-shooting, do a visual check and verify that proper voltages are present at the power source, transformers and power distribution board.

		DANGER SHOCK HAZARD
Always use caution when servicing a power supply when plugged in and the covers are removed. Dangerous voltages exist within the power supply which could cause injury or death.		

1. Disconnect line power by turning OFF the main disconnect switch.
2. Remove the power supply's top panel and 2 side panels.
3. Inspect interior of power supply for discoloration on PC boards, or other apparent damage. If a component or module is obviously defective, replace it before doing any testing. Refer to the *Parts List* section to identify parts and part numbers.
4. If no damage is apparent, connect power to the power supply, and turn ON the main disconnect switch.
5. Measure the voltage between the W, V and U terminals of TB1 located on the right side of the power supply. See figure on next page. Also refer to the wiring diagram in Section 7, if required. The voltage between any 2 of the 3 terminals should be equal to the supply voltage. If there is a problem at this point, disconnect main power and check connections, power cable, and fuses at line disconnect switch. Repair or replace any defective component.

Power measurement



**DANGER
SHOCK HAZARD**

There is line voltage at the contactor and the power distribution board (PCB2) when the line disconnect switch is on. Use extreme care when measuring primary power in these areas. Voltages present at the terminal block and contactors can cause injury or death.

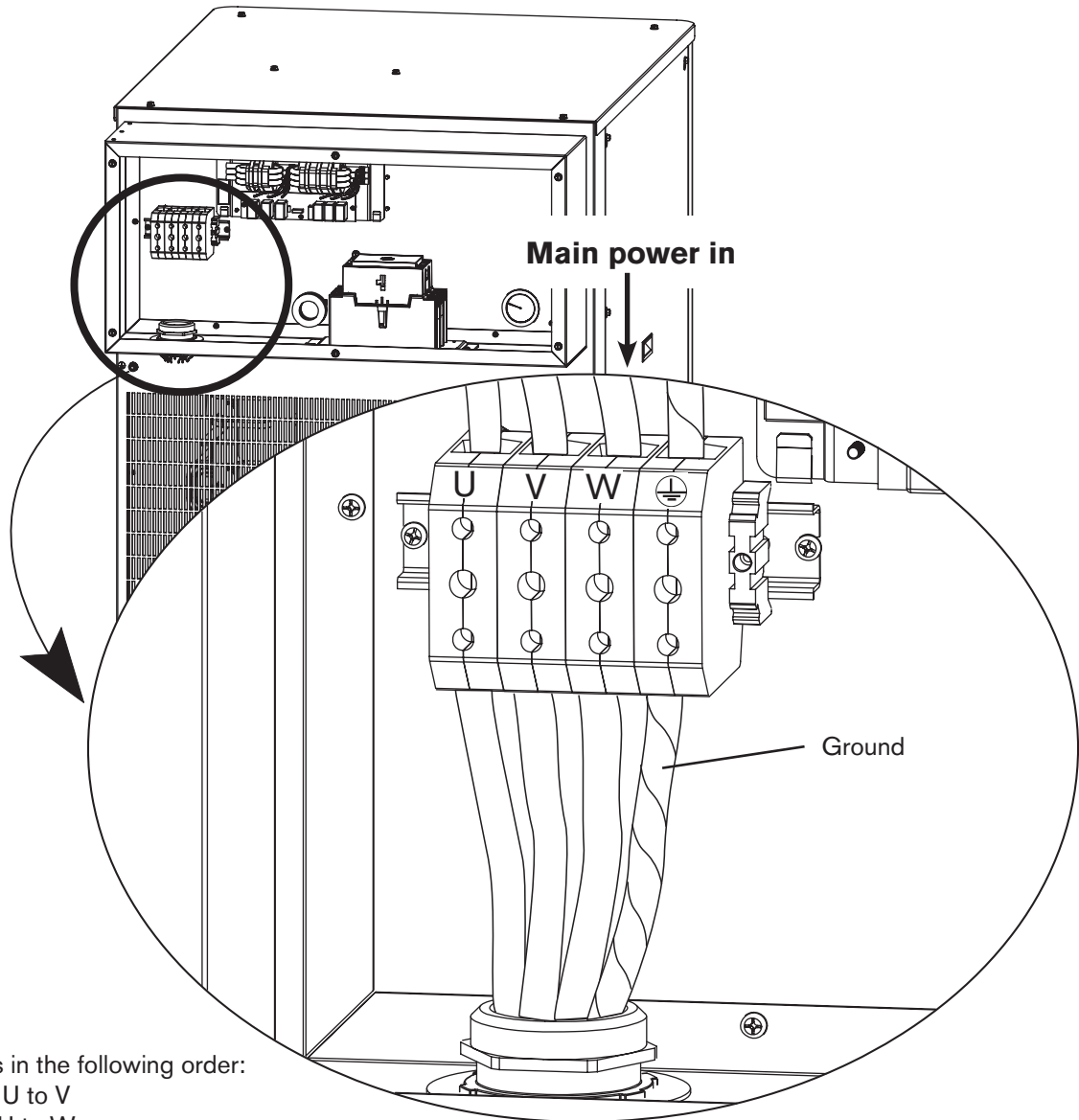

Note: Check lines in the following order:

- U to V
- U to W
- V to W

Check each line to ground. If one line is 10% greater, or more, than the other two, put that leg on U.

Air filter element replacement

1. Turn OFF all electrical power and disconnect the air hose from the filter.
2. Remove the filter bowl by turning it counter clockwise until it releases.
3. Pull the clear filter housing down firmly to remove it. The filter housing has an O-ring around the top. Apply a thin film of silicone lubricant on the O-ring to extend it's life. The O-ring should look shiny, but there should not be any excess or built-up grease.

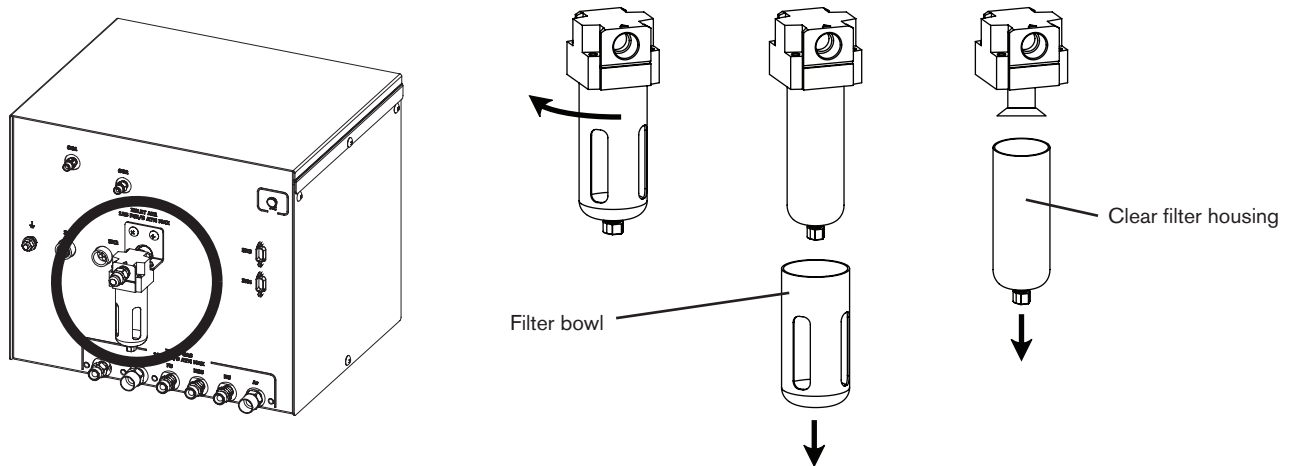

4. Use a screwdriver to remove the filter element from the filter housing. Then install the new filter element.
 Note: Do not allow the filter element to turn when loosening the screw.

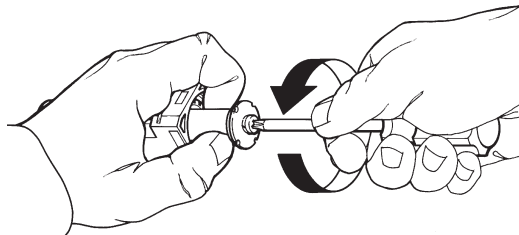

5. Reinstall the clear filter housing and the filter bowl.

Coolant system servicing

Draining the coolant system

1. Turn OFF all power to the plasma system and the chiller.
2. Drain the coolant system. See the chiller manufacturer manual for how to drain the chiller coolant system.

3. Turn ON the pump manually, using the manual pump control button on your CNC screen. The valve in the chiller interface console will open and coolant will drain out of the coolant hose.

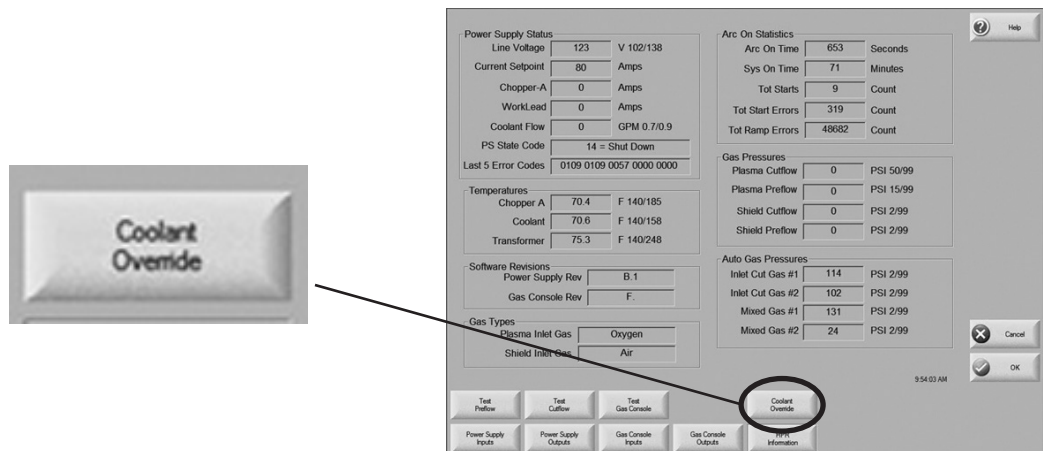

4. Turn OFF the pump immediately when the coolant flow slows significantly.
5. Reconnect the return coolant hose and make sure the 3/4 inch female NPT connection is closed.

Caution: Coolant will flow from the filter when its housing is removed. Drain coolant before servicing the filter.



Chiller interface coolant filter

Filter replacement

1. Turn OFF all power to the system.
2. Remove the filter housing.
3. Remove and discard the filter element.
4. Install the new filter element 027664.
5. Re-install the housing.
6. Refill the chiller with new coolant.

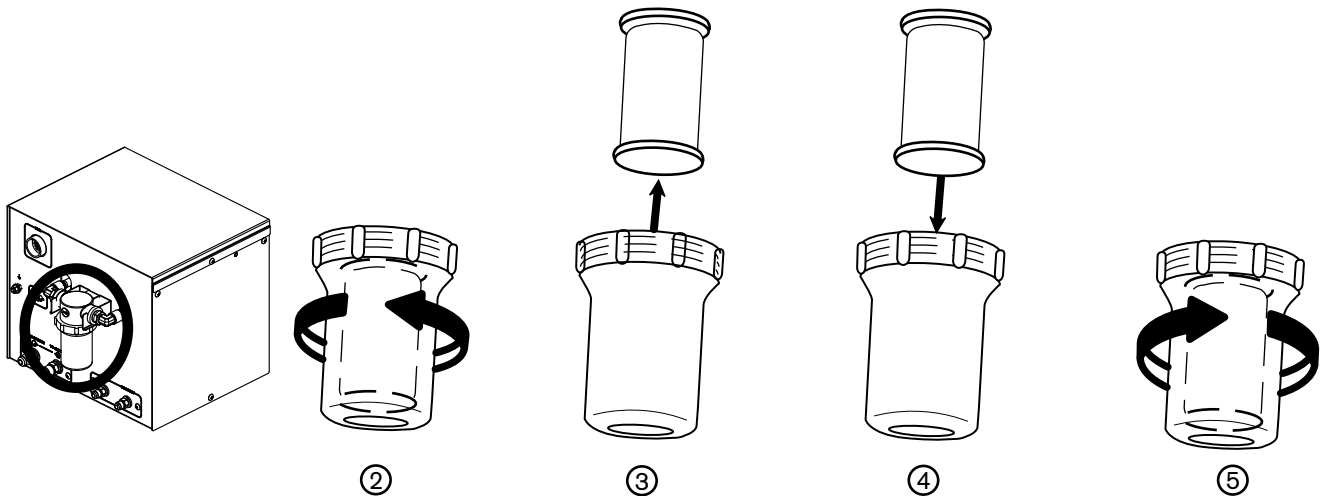

Gas leak tests

Notes: The CNC screen shown below is from a Hypertherm Automation controller, using version 6 software, and is for reference only. Other controllers should have a test screen similar to the one shown. Contact the original equipment manufacturer for instructions on how to access the test screen needed.

See sheet 20 of 24 on schematic 013381, in this manual, for more details on the gas delivery system.

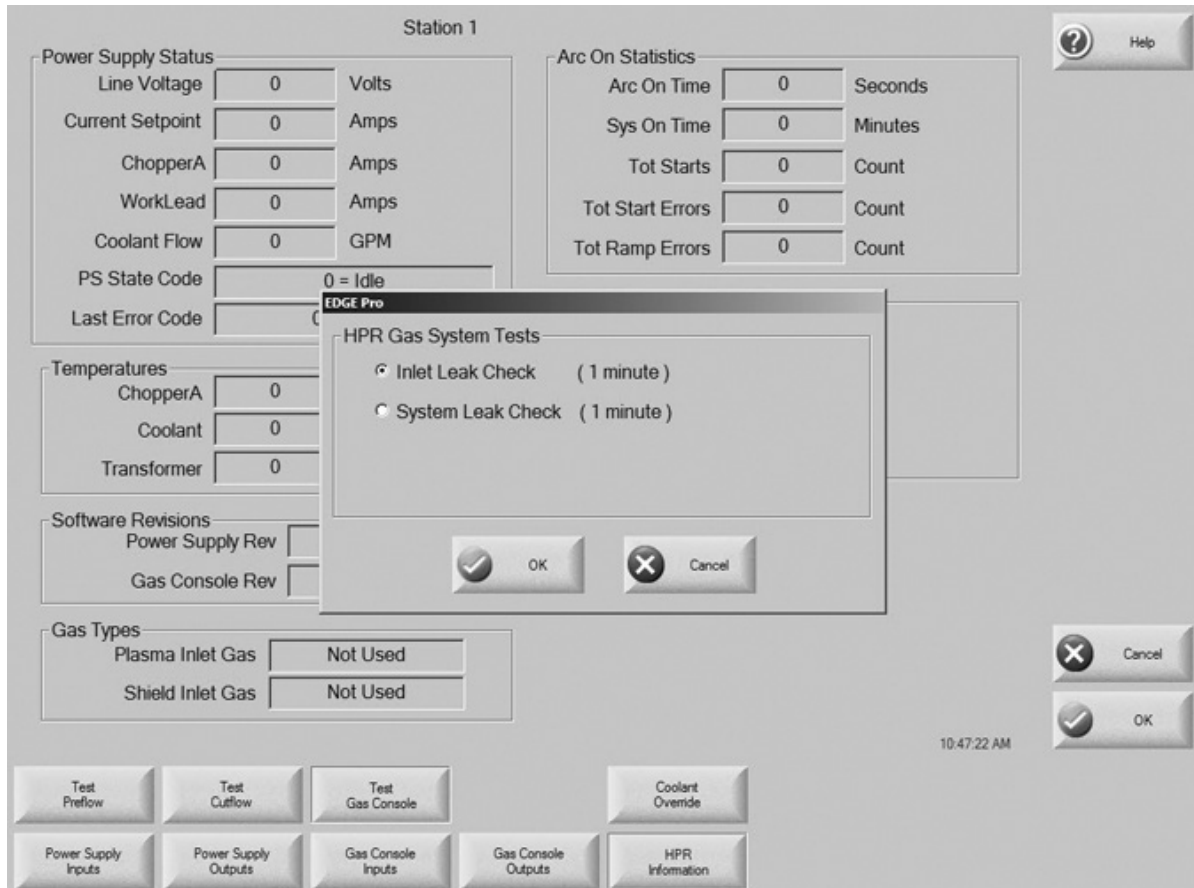

Leak test 1 (inlet leak test)

Purpose: Tests the inlet-valve solenoids in the selection console for leaks.

Test description: The valves in the metering console (B1-B4) open to release all gas pressure to the atmosphere, then the valves close and pressure is monitored by P3 and P4 in the selection console. The pressure will increase if an inlet valve is leaking. Code number 14 (cut gas channel number 1 failed) or 15 (cut gas channel number 2 failed) will be displayed if there is a leak. Code number 13 (test passed) will be displayed if no leak is detected.

Procedure:

1. Turn ON power to the plasma system.
2. Perform Inlet Leak Check on the CNC controller.
3. Turn OFF power and then turn ON power. This will purge gases from the system.

Leak test 2 (system leak test)

Purpose: Tests for leaks to the atmosphere from the gas system.

Test description: The gas for the process selected is purged through the gas system. The metering console valves (B1-B4), and the inlet valves (for the selected process) in the selection console are closed. Gas pressure is now trapped in the system. The trapped pressure is monitored. Code number 14 (cut gas channel number 1 failed) or 15 (cut gas channel number 2 failed) will be displayed if the pressure drops faster than 0.14 bar/minute (2 psi/minute). Code number 13 will be displayed if the pressure decreases within the acceptable limit of 0.14 bar/minute (2 psi/minute).

Procedure:

1. Perform System Leak Check on the CNC controller.
2. Turn OFF power and then turn ON power. This will purge gases from the system.

Leak test 3 (proportional valve test in the metering console)

Purpose: Tests the Burkert valves (B1 and B3) in the metering console to ensure that they are working within the correct parameters.

Test description: 130-amp mild steel consumables, and the 30-amp O₂/O₂ mild steel process are used for this test, because there is a known flow rate.

Gas flows from the torch, and the Burkert valve that controls the plasma gas channel (B3) attempts to maintain the set plasma gas pressure (monitored by P7 and P8) by adjusting the valve dynamically. The signal percentage to the valve is measured (example – 65% on), and the value is checked against the expected range (55% – 75%). The test is successful if the signal percentage is within the expected range. Code number 14 (shield gas channel failed) or 15 (plasma gas channel failed) will be displayed if the test fails. The same test is repeated for the Burkert valve that controls the shield gas channel (B1).

For the next part of the test, the Burkert valve that controls the plasma gas channel (B3) is closed, and the pressure is measured milliseconds later (pressure should decrease). The test is successful if the pressure is below a given limit (0.69 bar [10 psi]). The same test is repeated on the shield gas channel (B1).

Code number 16 (plasma ramp-down test failed) or 17 (shield rampdown test failed) will be displayed if the signal percentage is out of the expected range. Code number 13 (test passed) will be displayed if the signal percentage is within the expected range.

Procedure:

1. Install 130-amp mild steel consumables in the torch and select the 30-amp O₂/O₂ mild steel process.
2. Perform Metering Valve Flow Check on the CNC controller (test 3).
3. Turn OFF the power and then turn ON the power. This will purge gases from the system.

Power supply power distribution board PCB2

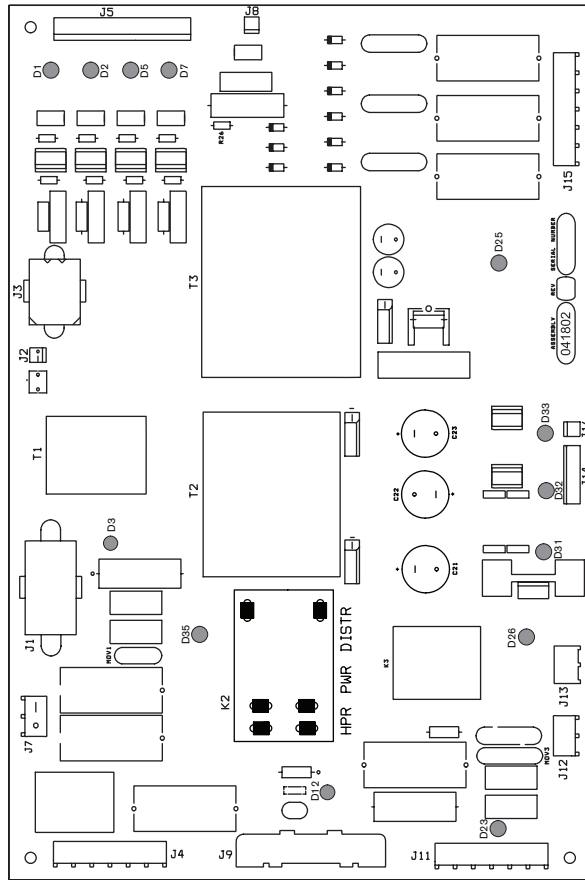
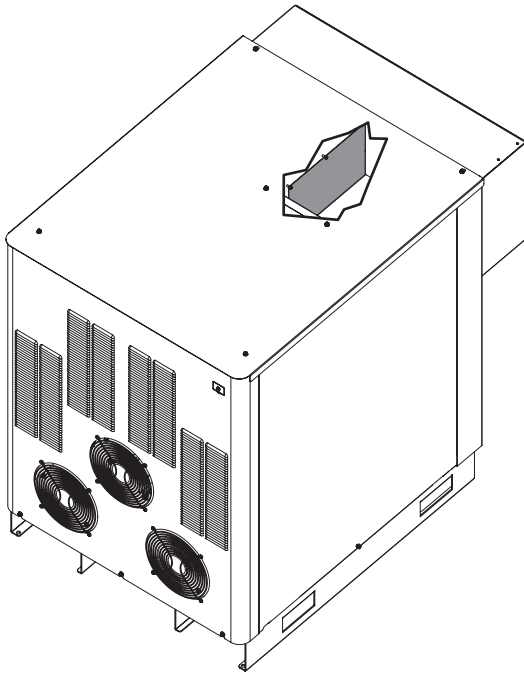

Power distribution PC board LED list		
LED	Output	Color
D1	Contactor	Red
D2	Pilot arc relay	Red
D3	120 VAC (switched)	Green
D5	HF ignition	Red
D7	Surge select	Red
D12	24 VAC (switched)	Green
D23	240 VAC (switched)	Green
D25	+ 24 VDC	Red
D26	Pump motor	Green
D31	+ 5 VDC	Red
D32	- 15 VDC	Red
D33	+ 15 VDC	Red
D35	24 VAC	Green

Start-circuit PCB1

Operation

The start circuit is a high-speed switch that quickly transfers the pilot arc current from the pilot arc lead to the work lead. The start circuit performs 2 functions:

1. It allows the initial pilot arc current to flow through the pilot arc lead quickly, with little impedance.
2. After initial pilot arc current is established, the start circuit introduces impedance to the pilot arc lead to aid in transferring the arc to the workpiece. See schematic below.

Start circuit functional schematic

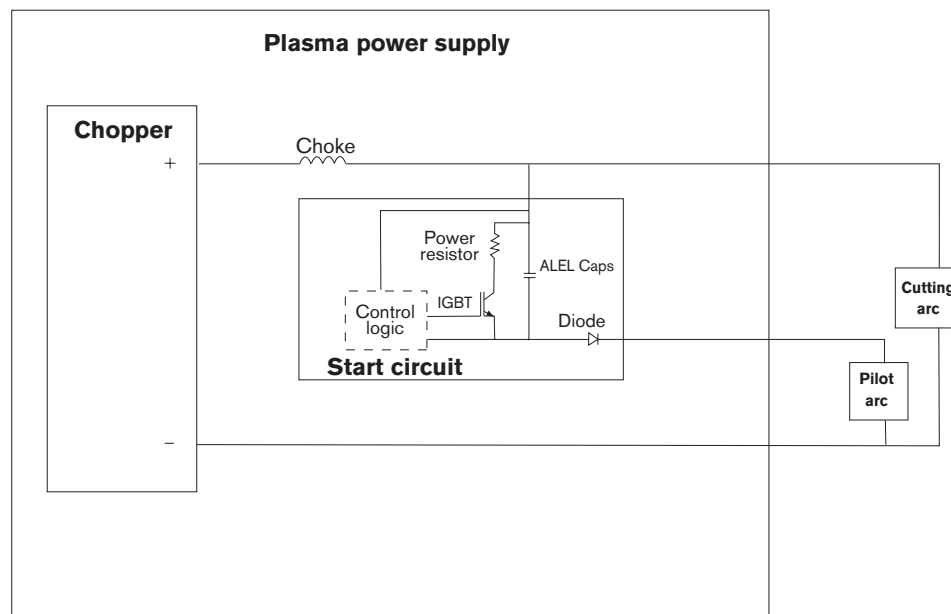

Start circuit troubleshooting

		<p>DANGER SHOCK HAZARD</p>
<p>Always use caution when servicing a power supply when plugged in and the covers are removed. Dangerous voltages exist within the power supply which could cause injury or death.</p>		

MAINTENANCE

D2 should always be illuminated when the plasma power supply is on. If D2 is not illuminated:

1. Verify the board is receiving power.
2. If it is receiving power, replace the board.

D1 indicates the start circuit board is getting a control signal. It also illuminates as soon as the torch fires and will extinguish as soon as the arc transfers to the workpiece. If arc transfer is immediate, the LED will not illuminate.

If there is no arc at the torch or if the arc will not transfer:

1. Turn OFF all power to the system.
2. Inspect the start circuit board for burned/broken components or loose connections. If there is damage, replace the start board.
3. Check the resistance between H8 and D50 (-) reads between $4.0\text{k}\Omega$ and $4.5\text{k}\Omega$ (the standard is $4.27\text{k}\Omega$). If the reading is outside this range, replace the start board.
4. The resistance reading between the snubber and H8 should read between $14.5\text{k}\Omega$ and $15.5\text{k}\Omega$ (the standard is $15.1\text{k}\Omega$). If the reading is outside this range, replace the start board.

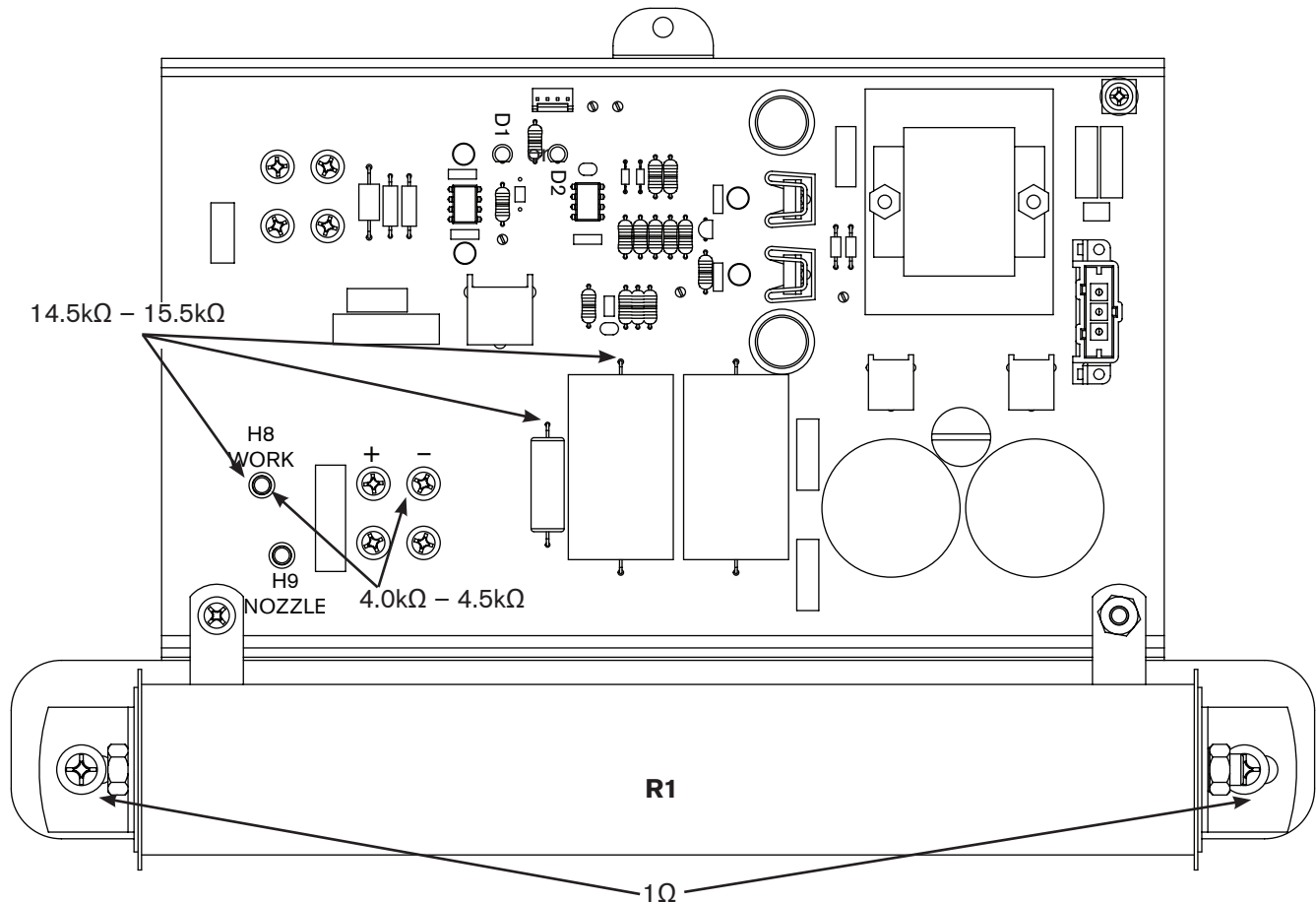
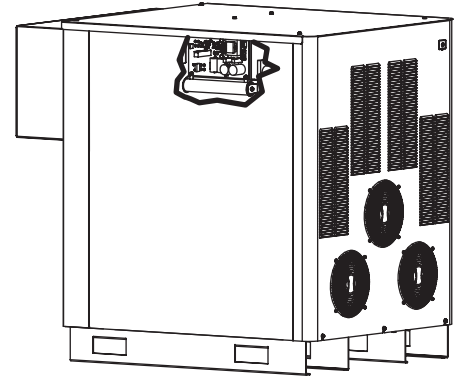

Pilot arc current levels

The pilot arc current level will vary according to the arc current selected, and the process. See table below.

Pilot arc current										
Plasma gas	30 amps	45 amps	50 amps	80 amps	130 amps	200 amps	260 amps	400 amps	600 amps	800 amps
O ₂	25	30	30	30	30	40	40	60	60	60
N ₂	25	30	30	30	35	40	40	60	60	60
H35	25	30	30	30	35	40	40	60	60	60
F5	25	30	30	30	35	40	40	60	60	60
Air	25	30	30	30	35	40	40	60	60	60

Transfer current										
Plasma gas	30 amps	45 amps	50 amps	80 amps	130 amps	200 amps	260 amps	400 amps	600 amps	800 amps
O ₂	10	10	10	10	15	20	20	30	30	30
N ₂	10	10	10	10	15	20	20	30	30	30
H35	10	10	10	10	15	20	20	30	30	30
F5	10	10	10	10	15	20	20	30	30	30
Air	10	10	10	10	15	20	20	30	30	30

Pilot arc relay wiring

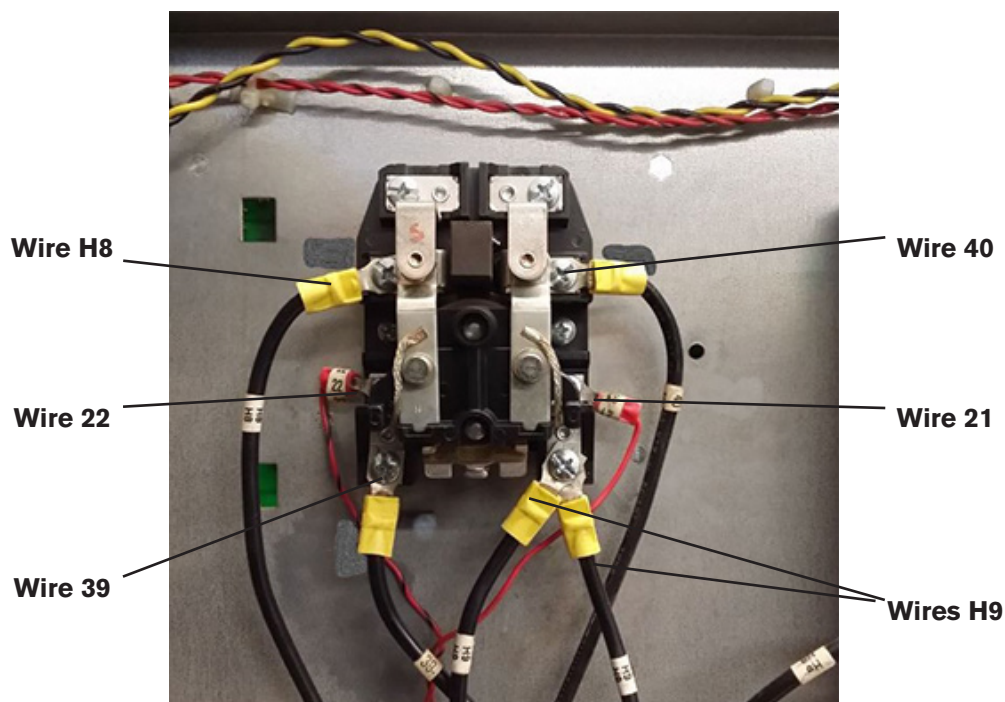

Pump motor drive board PCB7

Note: The inductor on the pump motor-drive board makes a noise during operation that has been described as a “hum”, “sing”, and “click”. This is normal and can be disregarded.

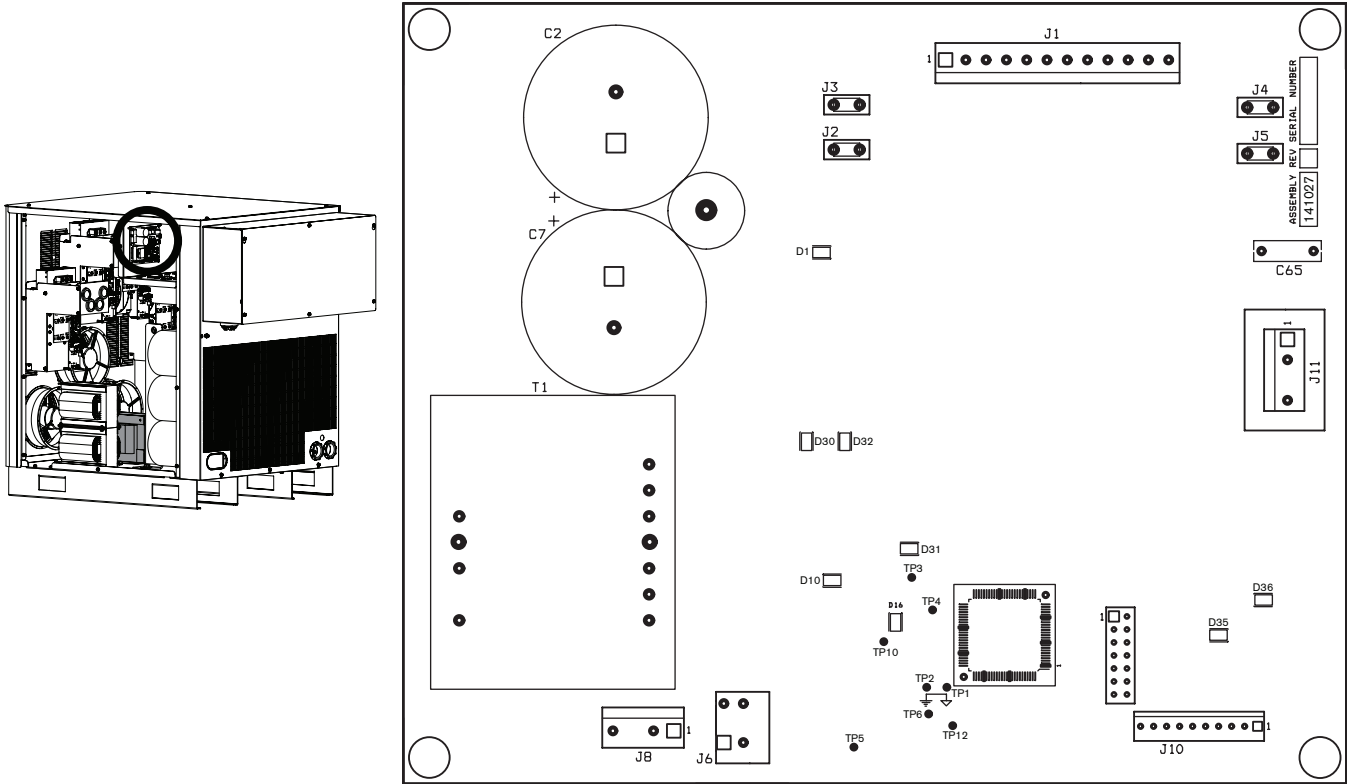

Control PCB LED list		
LED	Description	Status
D1	+ 15 V OK	On when +15 voltage is OK
D10	+ 5 V OK	On when +5 voltage is OK
D16	+ 3.3 V OK	On when +3.3 voltage is OK
D30	IPM temperature alarm output	Off when OK. On when there is a sustained over-current condition.
D31	Temperature	Off when OK. On when there is a temperature fault.
D32	IPM alarm output	Off when OK. On when there is an internal overtemp, over-current, or bad gate supply-drive voltage.
D35	Pump motor drive OK	On when pump-motor-drive is OK
D36	Pump motor drive enable	On when enabled

Control PCB test points					
Test point number	Description	Test point number	Description	Test point number	Description
TP1	Analog ground	TP5	+ 5 V	TP9	Digital ground
TP2	Digital ground	TP6	A + 3.3 V	TP10	+ 3.3 V
TP3	Reset\	TP7	+ 3.3 V	TP11	SCIRXD
TP4	Reset	TP8	SCITXD	TP12	LINEFB +

Chiller interface power distribution board PCB1

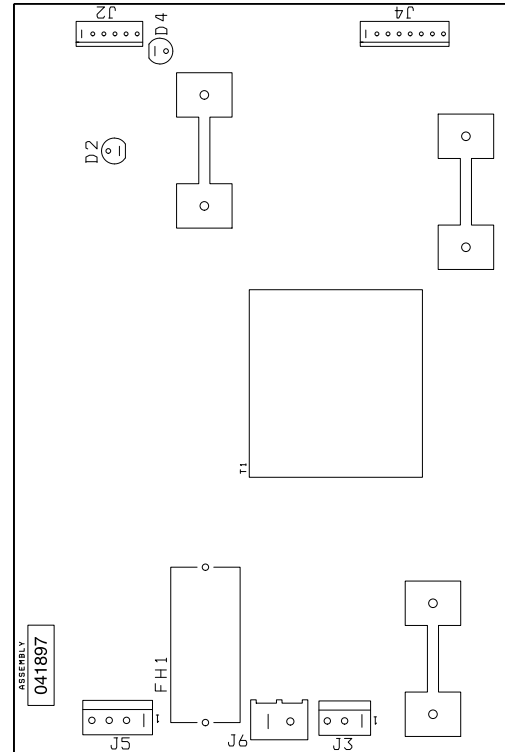
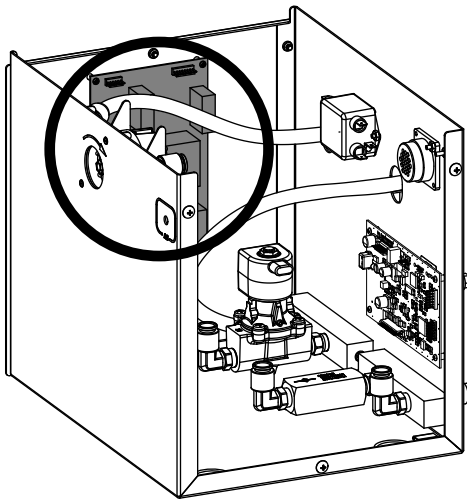

Chiller interface power distribution board LED list		
LED	Signal name	Color
D2		Red
D4	+ 5 VDC	Green

Coolant sensor board PCB2

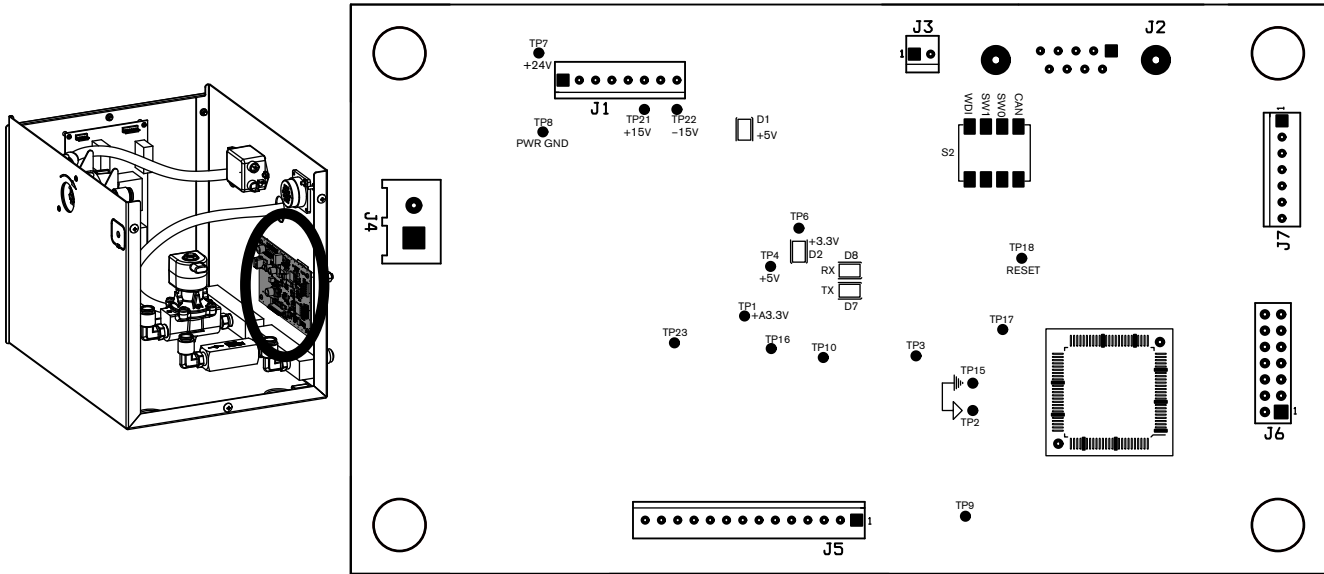

Coolant sensor board LED list		
LED	Signal name	Color
D1	+ 5 VDC	Red
D2	+ 3.3 VDC	Green
D7	CAN TX	
D8	CAN RX	

Control PCB test points			
Test point number	Description	Test point number	Description
TP1	A + 3.3 V	TP12	Digital ground
TP2	Analog ground	TP13	+ 3.3 V
TP3	Pressure sensor (for use in the future)	TP14	SCIRXD (RS422 transmit)
TP4	+ 5 V	TP15	Digital ground
TP6	+ 3.3 V	TP16	Analog ground
TP7	+ 24 V	TP17	Reset\
TP8	Power ground	TP18	Reset
TP9	Coolant flow sensor input	TP21	+ 15 V
TP10	Chiller flow input (for use in the future)	TP22	- 15 V
TP11	SCIRXD (RS422 receive)	TP23	Line voltage input

Selection console control board PCB2

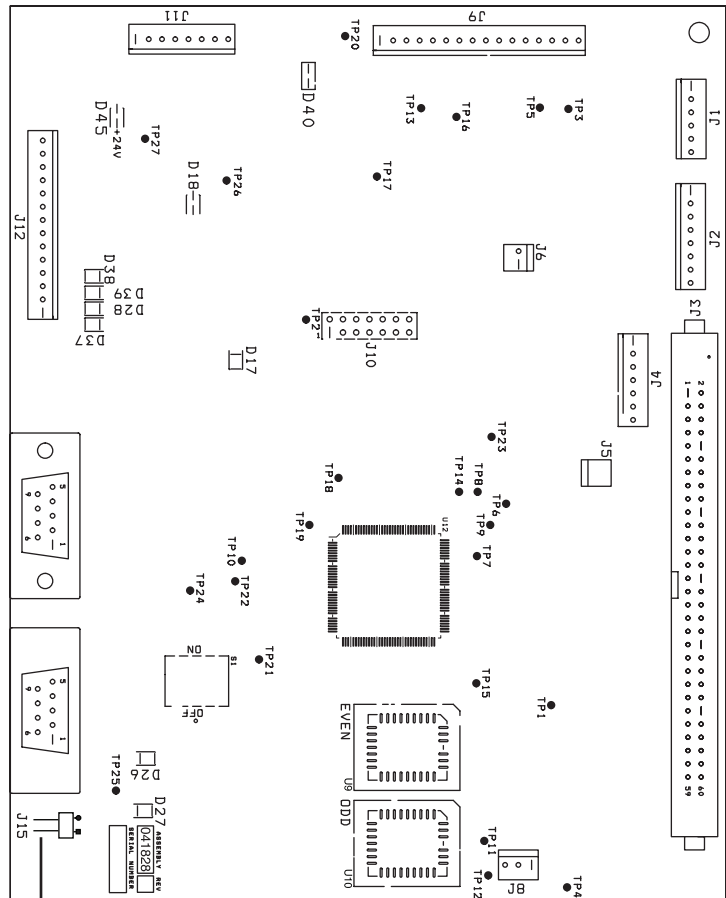
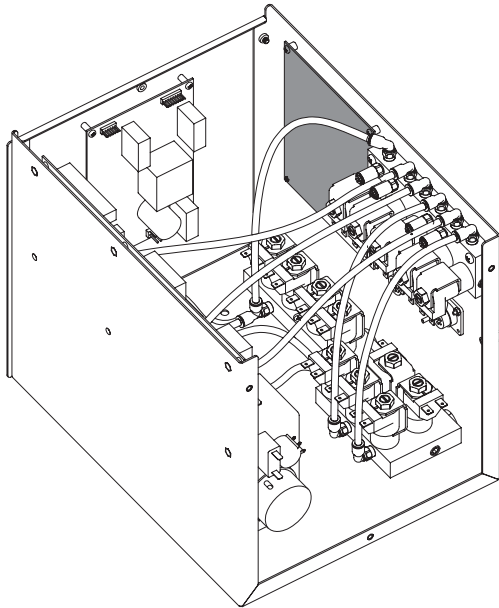

Note: CAN termination resistor. The jumper must be removed.

Control PCB2 firmware list

Item	Part number
U9	081110 EVEN
U10	081110 ODD

Gas console control board LED list

LED	Signal name	Color
D17	+ 3.3 VDC	Green
D18	+ 5 VDC	Green
D26	CAN – RX	Green
D27	CAN – TX	Green
D28	Not used	Red
D37	Not used	Red
D38	Not used	Red
D39	Not used	Red
D40	+ 15 VDC	Green
D45	+ 24 VDC	Green

Selection console power distribution board PCB1

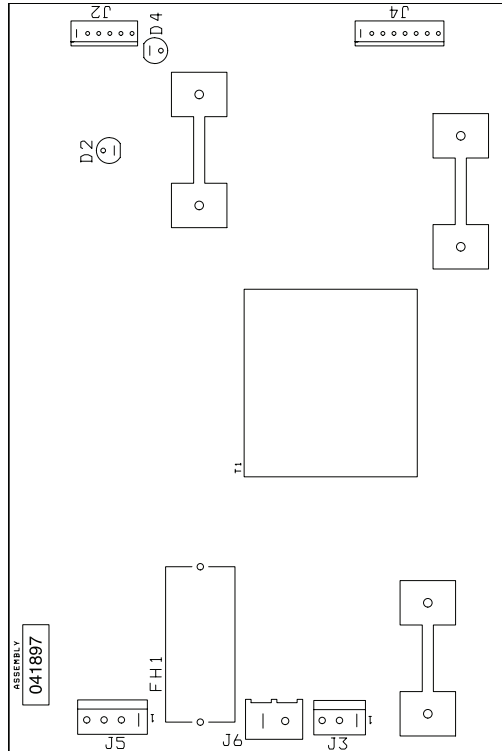
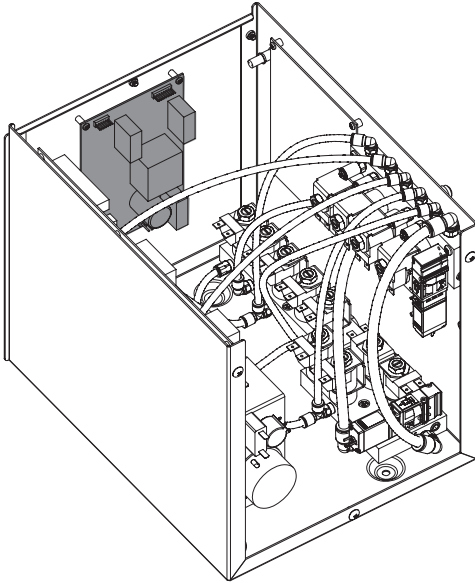

Gas console control board LED list		
LED	Signal name	Color
D2		Red
D4	+ 5 VDC	Green

Selection console, AC valve-driver board PCB3

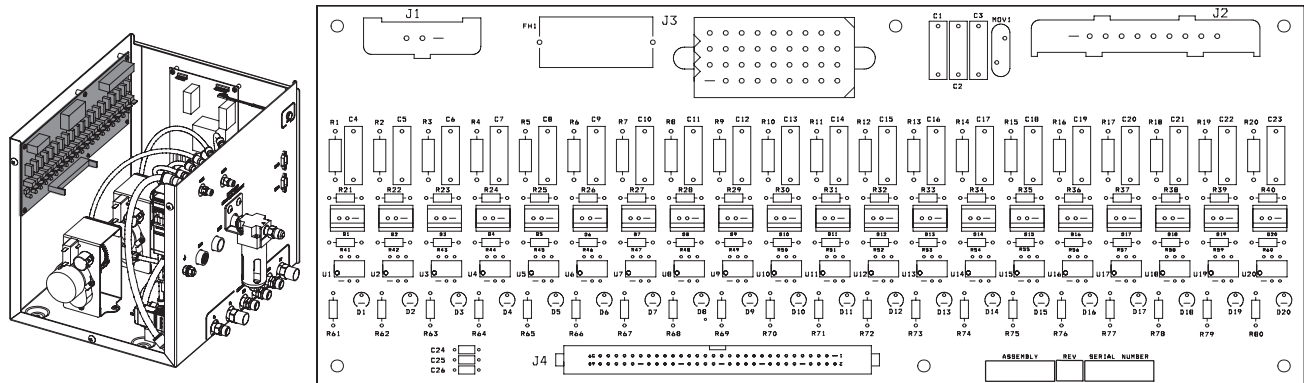

LED	Signal name	Color	LED	Signal name	Color
D1	SV1	Red	D11	SV11	Red
D2	SV2	Red	D12	SV12	Red
D3	SV3	Red	D13	SV13	Red
D4	SV4	Red	D14	SV14	Red
D5	SV5	Red	D15	(not used)	Red
D6	SV6	Red	D16	Metering console vent solenoid	Red
D7	SV7	Red	D17	MV1 close	Red
D8	SV8	Red	D18	MV1 open	Red
D9	SV9	Red	D19	MV2 close	Red
D10	SV10	Red	D20	MV2 open	Red

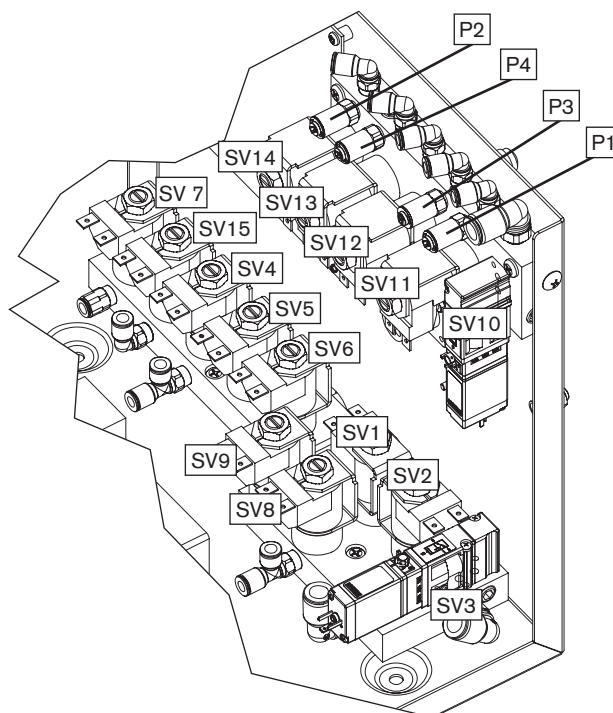

Metering console control board PCB2

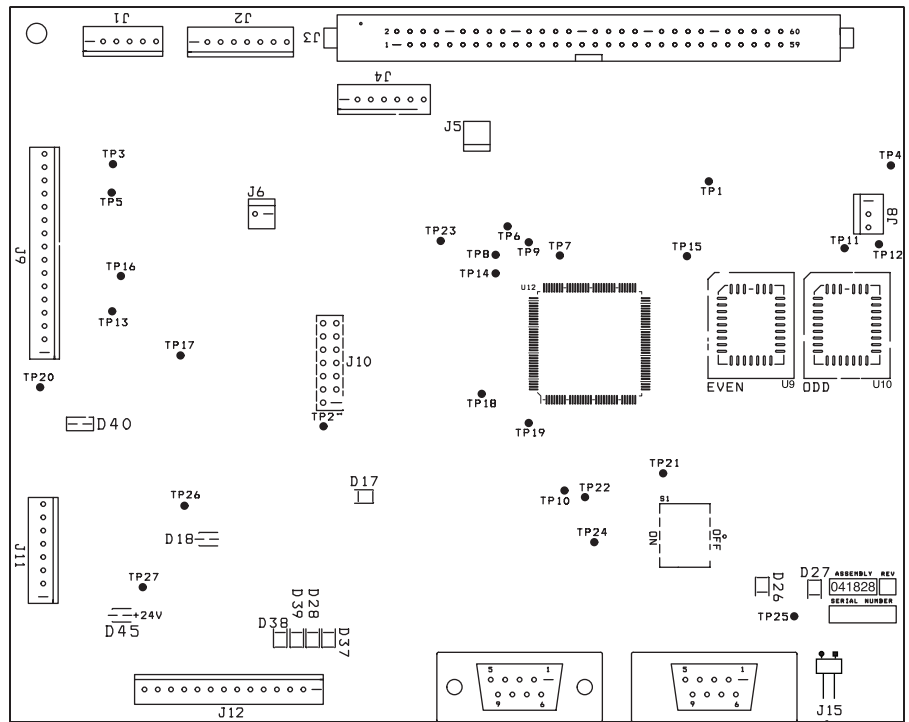
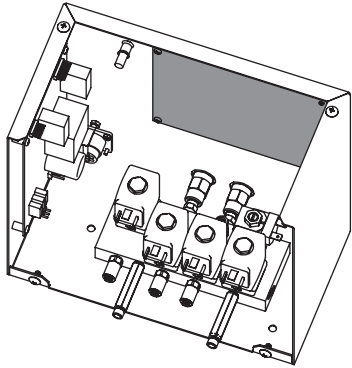

Note: CAN termination resistor. The jumper must be installed.

Control PCB2 firmware list	
Item	Part number
U9	081110 EVEN
U10	081110 ODD

Gas console control board LED list		
LED	Signal name	Color
D17	+ 3.3 VDC	Green
D18	+ 5 VDC	Green
D26	CAN – RX	Green
D27	CAN – TX	Green
D28	Burkert valve 2	Red
D37	Burkert valve 1	Red
D38	Burkert valve 4	Red
D39	Burkert valve 3	Red
D40	+ 15 VDC	Green
D45	+ 24 VDC	Green

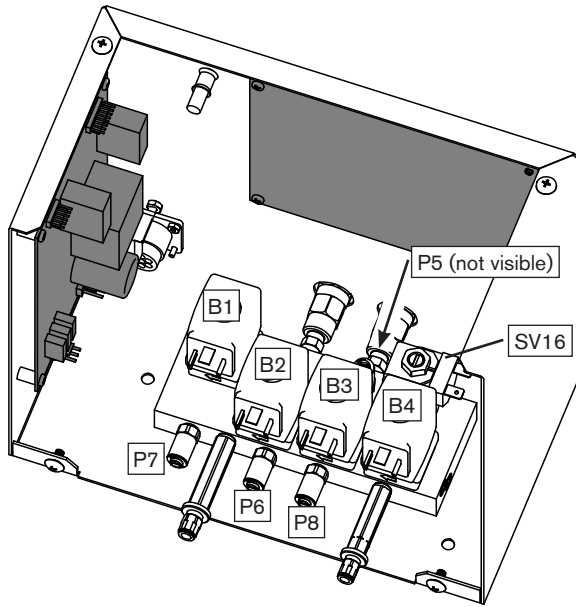

Metering console power distribution board PCB1

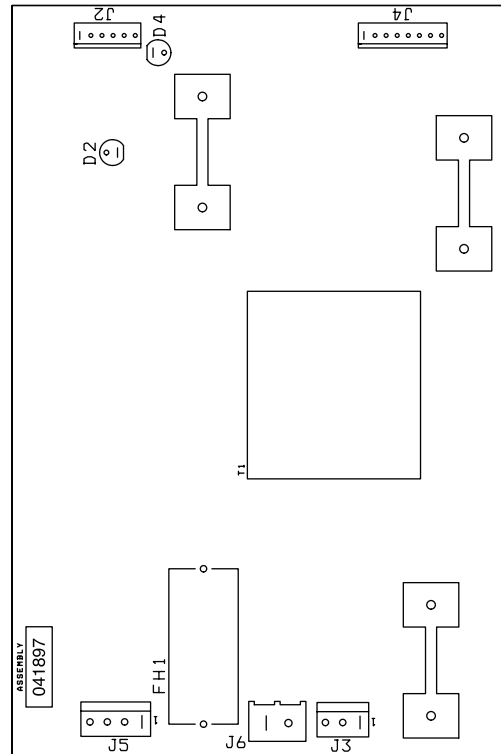
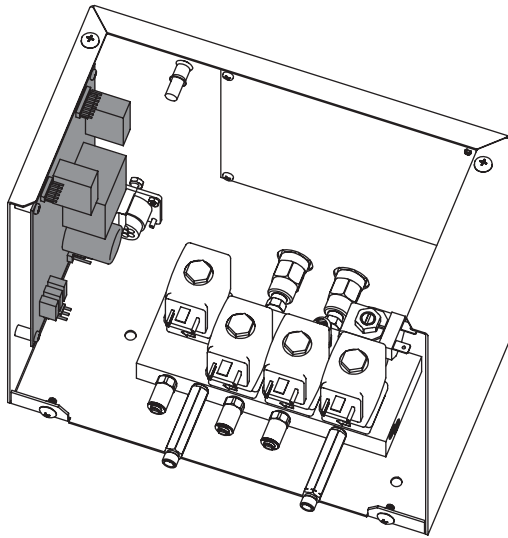

Metering console power distribution board LED list		
LED	Signal name	Color
D2	SV16	Red
D4	+ 5 VDC	Green

Chopper tests



WARNING SHOCK HAZARD

Use extreme care when working near the chopper modules. Each large electrolytic capacitor (blue-cased cylinder) stores large amounts of energy in the form of electric voltage. Even if the power is off, dangerous voltages exist at the capacitor terminals, on the chopper, and the diode heatsinks. Never discharge any capacitor with a screwdriver or other implement... explosion, property damage and/or personal injury will result.

Automatic chopper tests during power-up

When the power is turned ON, the contactor will close and each chopper will automatically test in sequence (1, 3, 2, and 4). If the status changes to 3, all choppers passed the test. After the tests are complete the unit will advance to the purge cycle unless an error is detected on one of the choppers.

As each chopper is turned on, the current flows into the surge circuit and is measured for high and low limits. If the chopper passes the test, the next chopper is tested.

If chopper 1 passes the test and one of the other choppers fails, you can assume that the main contactor, the input power, and the surge circuit are OK.

Error codes:

Chopper 1 – low-current error code 105
Chopper 1 – high-current error code 103

Chopper 3 – low-current error code 075
Chopper 3 – high-current error code 107

Chopper 2 – low-current error code 106
Chopper 2 – high-current error code 104

Chopper 4 – low-current error code 076
Chopper 4 – high-current error code 095

Chopper 1 failure

1. Turn OFF all power to the system.
2. Remove the cover over the main contactor (CON1) and inspect the contacts for arcing or damage.
 - If the contacts are damaged, replace the contactor.
 - If the contacts are OK, replace the cover, turn ON the power, and continue to step 3.

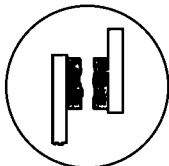

OK

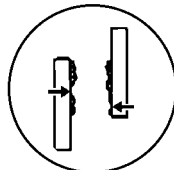

Excessive wear

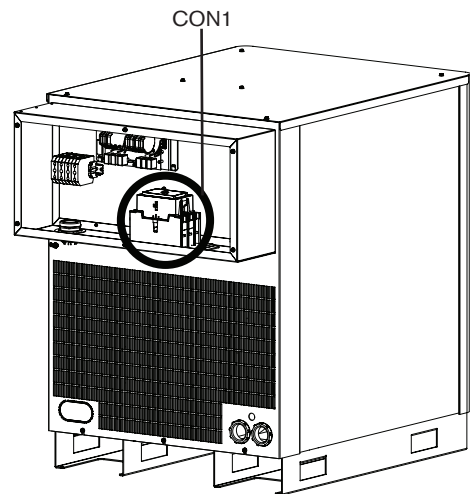

3. Locate dipswitch S301 on the control board (PCB3) and move switch 5 to the ON position. The switch must be returned to its original position before cutting.
4. Measure the open circuit voltage (OCV)
Attach the test leads of a DC volt meter to the NEG terminal and the WORK terminal on the I/O board. Turn ON the power to start the chopper test. After the contactor (CON1) closes, read the OCV which should be about 360 VDC.
 - If the OCV is 0, the chopper is probably faulty. Swap chopper 1 with chopper 2 for verification. If chopper 1 is faulty, the error code should change to 106. Replace chopper 1.
 - If OCV is about 360 VDC, continue to step 5.
5. Swap current sensor 1 (CS1) with current sensor 2 (CS2). Move the sensor, but leave the power cable and the control wiring in place.
 - If the error remains on chopper 1, replace the I/O PCB.
 - If the error changes to chopper 2, replace CS1.

Chopper 3, 2, or 4 failure

1. Swap the current sensor for the chopper that failed with the current sensor for the next chopper in sequence.
 - If the error moves to the next chopper in sequence, replace the current sensor for the chopper that failed.
 - If the error remains on the original chopper, continue to step 2.
2. Swap the chopper that failed with the next chopper in sequence. Remember that the chopper test sequence is chopper 1, chopper 3, chopper 2, and chopper 4.
 - If the error moves to the position where you installed the chopper that failed, replace the chopper.
 - If the error remains on the original chopper, the issue is with the control board or wiring.

Note: Return switch 5 on S301 to the OFF position before returning to normal cutting operations.

Phase-loss detection test

1. Turn OFF all power to the system and remove the cover from CON1.

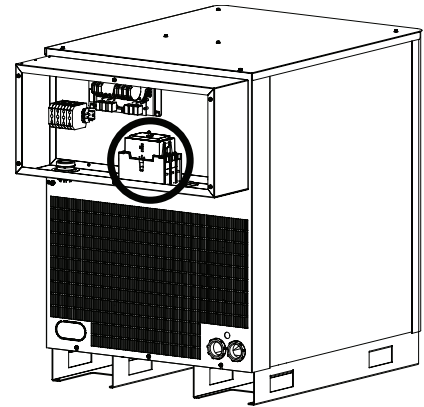

2. Inspect the condition of the 3 contacts for excessive wear. If one or more of the contacts are worn excessively, replace CON1 and restart the system. If the error remains, perform the following steps.

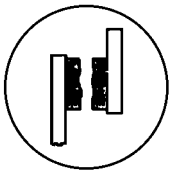

OK

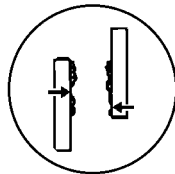

Excessive wear

3. Test the fuses F5, F6, and F7 on the power distribution board (PCB2). If any of the fuses are blown, replace PCB2.

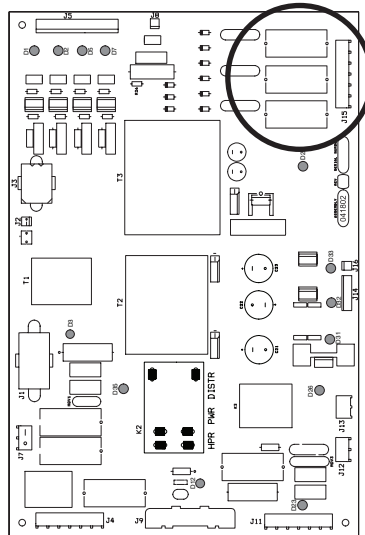

4. Remove J2.8 from PCB2 and place a jumper between pins 1 and 2 on the cable connector.

- a. Make a test cut. If the phase-loss error continues, verify wiring between J2.8 on PCB2 and J3.302 on PCB3 by verifying the continuity between:
 - J2.8 pin1 to J3.302 pin14
 - J2.8 pin2 to J3.302 pin15.
- b. If the wiring is OK, replace PCB3. If any wiring is damaged, repair or replace any damaged wires.
- c. If the phase-loss error goes away while the jumper is on J2.8, make another cut and measure the phase-to-phase voltage across the fuses F5, F6, and F7. The voltage should be 220 VAC +/-15%. If 1 of the 3 voltage readings is less than 187 VAC, check the contacts to the contactor, and check for loose connections between the power cord, contactor, power transformer, and the chopper.



**WARNING
SHOCK HAZARD**

Always use caution when servicing a power supply when plugged in and the covers are removed. Dangerous voltages exist within the power supply which could cause injury or death.

Test continuity between the nozzle and workpiece

1. Turn OFF all power to the system.
2. Take the side panels off.
3. Locate the start-circuit assembly.

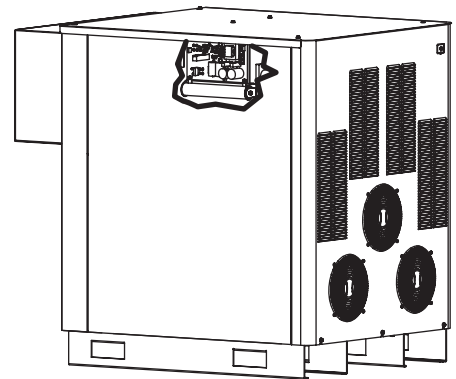

4. Install a temporary jumper wire between H8 (work) and H9 (nozzle) on the start circuit PCB1.

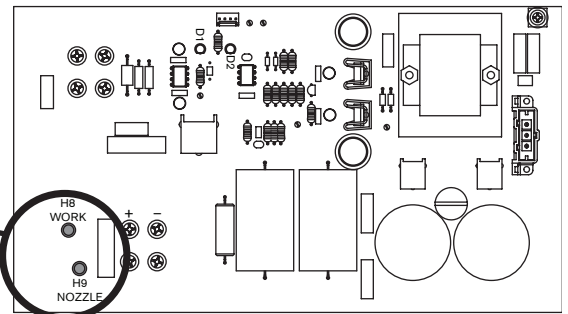
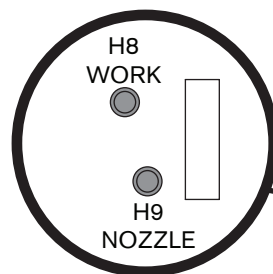

5. Locate the pilot arc relay (CR1) and remove the dust cover.

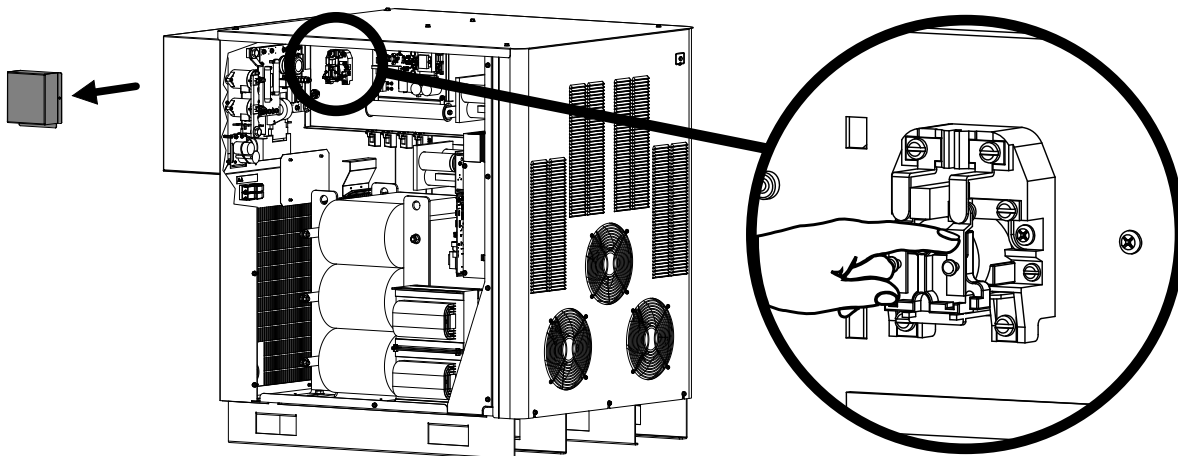

MAINTENANCE

6. Measure the ohm value between the nozzle and the plate (2 readings)
 - 6a. Without the pilot arc relay pushed in the reading should be 9800 ohms.
 - 6b. With a second person pushing in the pilot arc relay the reading should be less than 3 ohms.

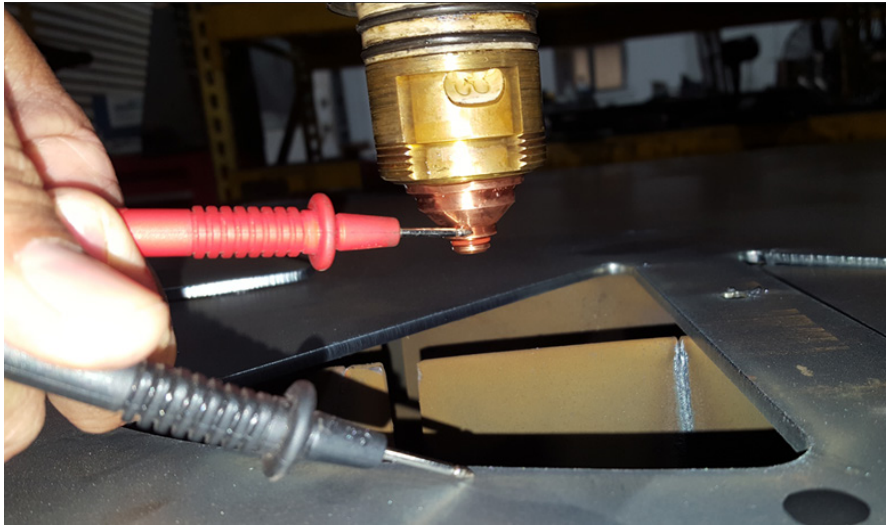

7. Verify that the pilot arc wire on the torch lead is not damaged. If it is damaged replace the lead. If it is not damaged, replace the torch head.

Preventive maintenance

Hypertherm created a Preventive Maintenance Program (PMP) specifically for your plasma system. The PMP has two parts: a cleaning and inspection schedule and a component replacement schedule.

See the *HPR800XD Auto Gas Preventive Maintenance Program Instruction Manual (808680)* for part numbers.

If you have questions about how to maintain your plasma system, contact your OEM or regional Hypertherm Technical Service team. You can find contact information for each regional office at www.hypertherm.com on the "Contact us" page after choosing your language.

Section 6

PARTS LIST

In this section

Power supply	6-2
Chiller.....	6-6
Chiller interface console.....	6-7
Ignition console	6-8
Torch lead junction box (Optional).....	6-9
Ignition console to junction box leads	6-10
Metering console	6-13
HyPerformance torch	6-14
Torch assembly.....	6-14
Torch leads	6-15
Ohmic contact wire.....	6-15
Consumable parts kits.....	6-16
Consumable parts kits.....	6-18
Consumables for mirror-image cutting	6-19
Straight cutting	6-19
Bevel cutting.....	6-21
Recommended spare parts	6-23
Warning Label – 110647.....	6-26

PARTS LIST

Power supply

Power supplies			
Primary	Primary with Hypernet	Secondary	Voltage (AC)
078578	078586	078594	200/208
078579	078587	078595	220
078580	078588	078596	240
078581	078589	078597	380
078582	078590	078598	400
078583	078591	078599	440
078584	078592	078600	480
078585	078593	078601	600

Note: The Hypernet option is currently used with the ArcGlide® torch height control. See the ArcGlide instruction manual (806450) for more information.

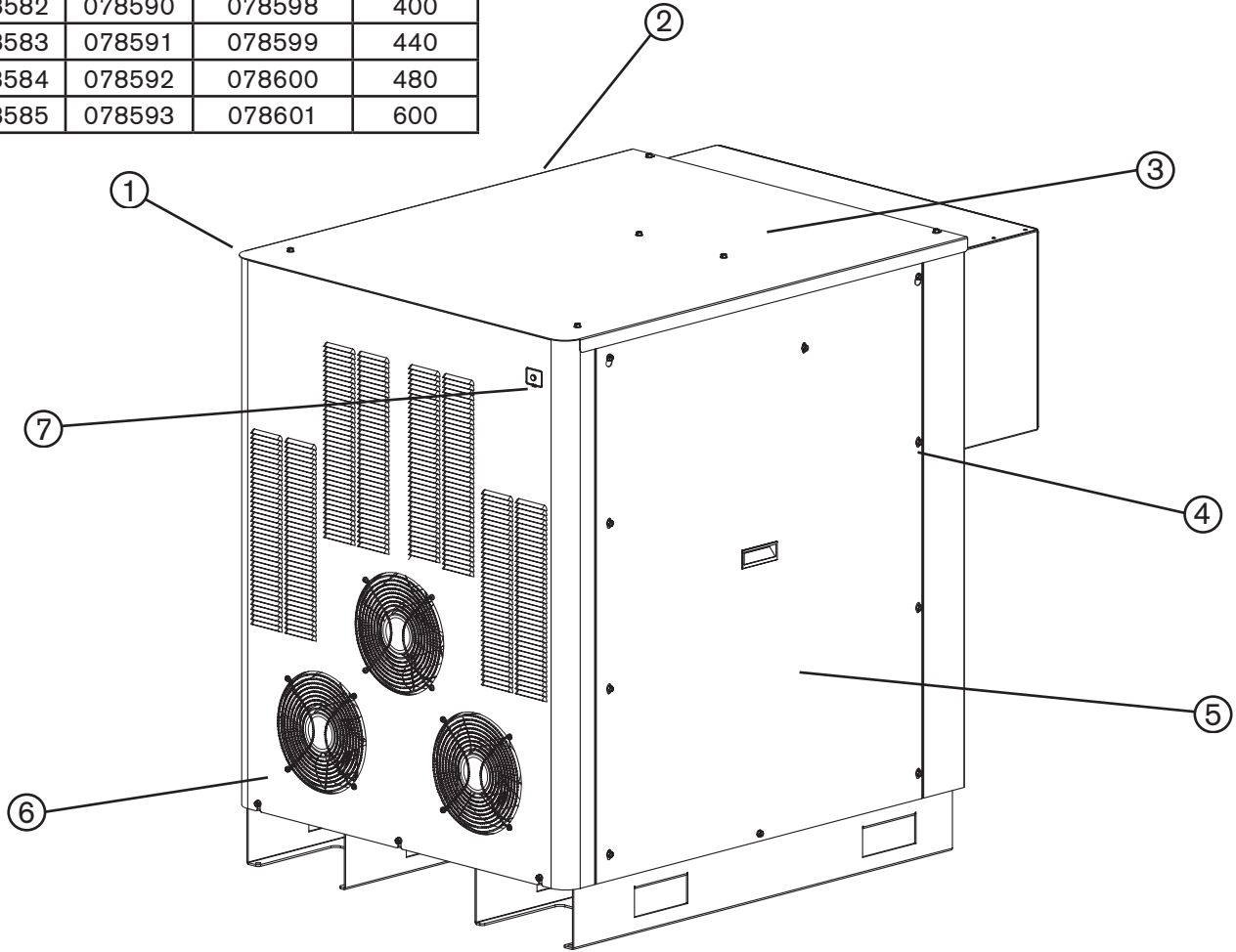

Item	Part Number	Description	Qty.
1	See table above	Power supply	
2	228609	Panel: Left side, with labels and handles (not shown)	1
3	228362	Panel: Top, with labels	1
4	075241	Sheet metal screws	1
5	228610	Panel: Right side, with labels and handles	1
6	228619	Panel: Front, with labels (Primary power supply)	1
	228620	Panel: Front, with labels (Secondary power supply)	1
7	129633	Green power lamp assembly	1
8	228604	Kit: Hypernet upgrade (not shown)	1

Power supply

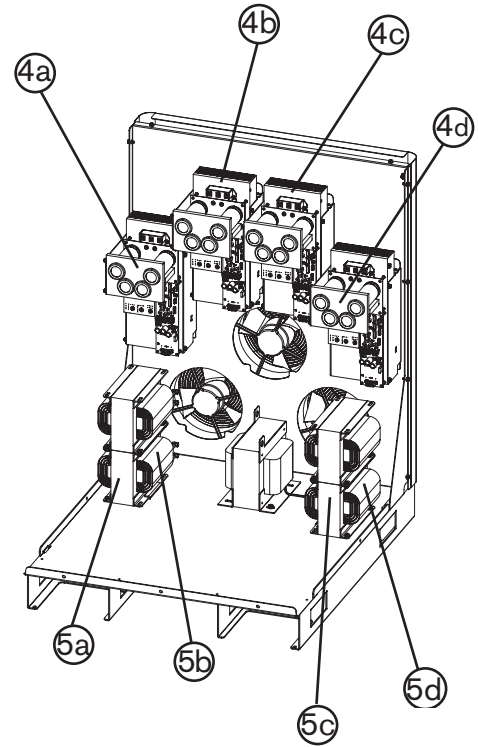
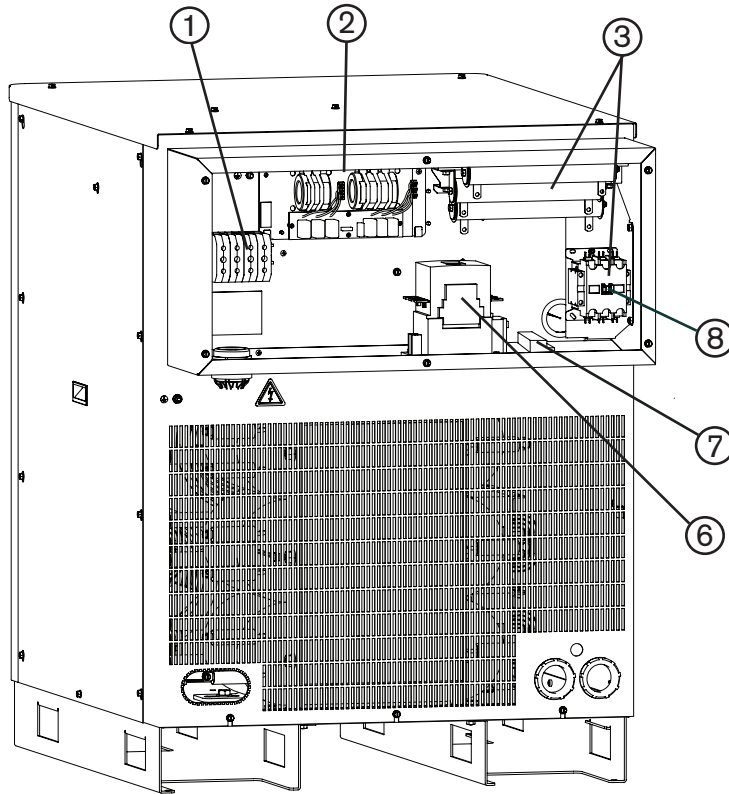

<u>Item</u>	<u>Part Number</u>	<u>Description</u>	<u>Designator</u>	<u>Qty.</u>
1	229214*	Terminal block: Input power	TB1	1
	229033**	Terminal block: Input power	TB1	1
2	229195	EMI filter (400 volt power supply only)		1
3	428064***	Kit: HPR400XD/800XD inrush-supression circuit		1
4a	129792	Chopper assembly	CHA	1
4b	129792	Chopper assembly	CHB	1
4c	129792	Chopper assembly	CHC	1
4d	129792	Chopper assembly	CHD	1
	127039	6" fan: 230 CFM, 115 VAC 50-60 HZ		8
5a	014080	Inductor: 100 amp, 4 mH	L1	1
5b	014080	Inductor: 100 amp, 4 mH	L2	1
5c	014080	Inductor: 100 amp, 4 mH	L3	1
5d	014080	Inductor: 100 amp, 4 mH	L4	1
6	003218*	Main contactor	CON1	1
	003233**	Main contactor	CON1	1
7	428382†	Kit: HPR400XD/800XD inrush PCB		1
8	003249	Inrush contactor		1

* 200, 220, and 240 volt power supplies

** 380, 400, 440, 480, and 600 volt power supplies

*** If your power supply does not have the inrush-suppression circuit, you can install kit 428064 to add it.

† If your power supply has an inrush-suppression circuit, you can install kit 428382 to upgrade it to an inrush PCB.

PARTS LIST

Power supply

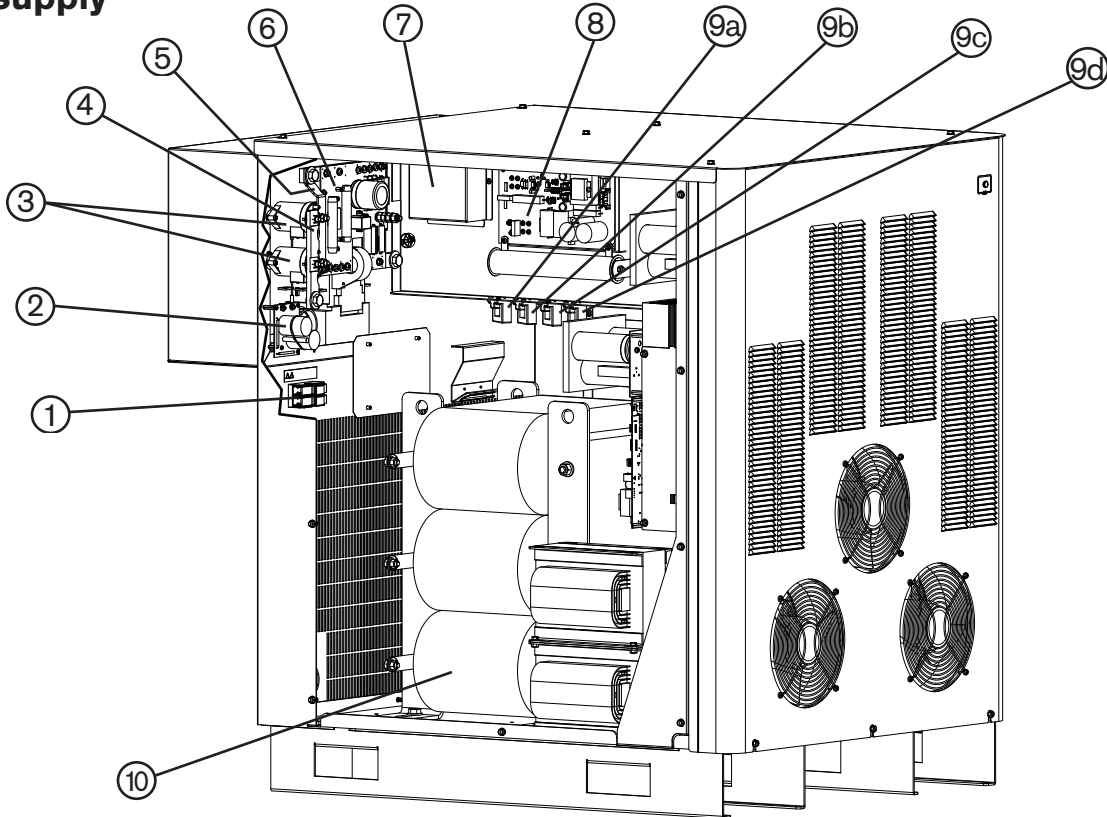

<u>Item</u>	<u>Part Number</u>	<u>Description</u>	<u>Designator</u>	<u>Qty.</u>
1	108847*	Fuse: 7.5 amp, 600 volt, high surge	F1, F2	2
	008709**	Fuse: 20 amp, 500 volt, slow blow	F1, F2	2
2	229340	Snubber assembly		1
3	229360	Contactora: 500 amp DC 120 VAC COIL	Con2, Con3	2
4	104496	Bus bar		1
5	104495	Bus bar		1
6	229213	PCB: I/O		1
7	003149***	Relay: Pilot arc, 120 VAC	CR1	1
8	229238	Start circuit assembly	PCB1	1
9a	109004	Current sensor: Hall 100 amp, 4 volt	CS1	1
9b	109004	Current sensor: Hall 100 amp, 4 volt	CS2	1
9c	109004	Current sensor: Hall 100 amp, 4 volt	CS3	1
9d	109004	Current sensor: Hall 100 amp, 4 volt	CS4	1
10	014321	200 volt main transformer: 80KW, 3 ph, 50 HZ	T2	1
	014322	220 volt main transformer: 80KW, 3 ph, 50 HZ		1
	014323	240 volt main transformer: 80KW, 3 ph, 60 HZ		1
	014324	380 volt main transformer: 80KW, 3 ph, 50 HZ		1
	014325	400 volt main transformer: 80KW, 3 ph, 50 HZ		1
	014326	440 volt main transformer: 80KW, 3 ph, 50 HZ		1
	014327	480 volt main transformer: 80KW, 3 ph, 60 HZ		1
	014328	600 volt main transformer: 80KW, 3 ph, 60 HZ		1
	228309	Kit: Thermistor replacement for main transformer		1

* 380, 400, 440, 480, and 600 volt power supplies

** 200, 220, and 240 volt power supplies

*** CR1 is located under the cover

Power supply

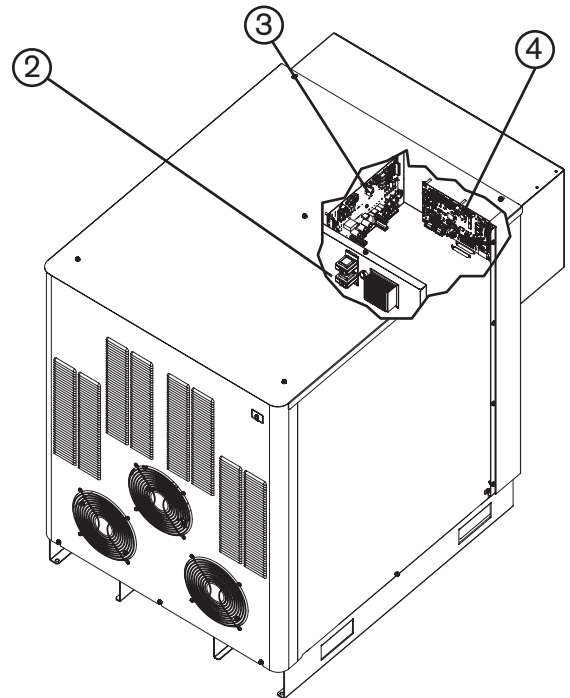
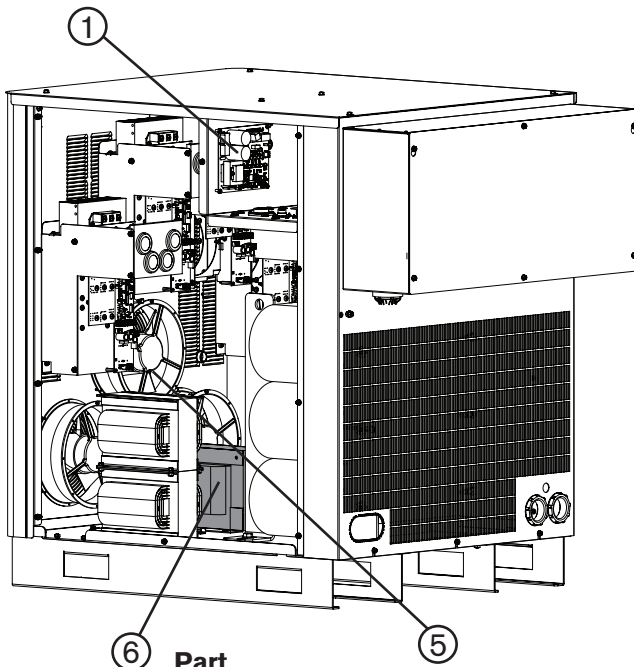

<u>Item</u>	<u>Part Number</u>	<u>Description</u>	<u>Designator</u>	<u>Qty.</u>
1	141027	PCB: Pump motor drive	PCB7	1
2	229212	Inductor: 5 amp, 1.4 mH		2
3	041802	Non-Eco Design PCB: Power distribution A power supply with serial number HPR800P-000297 or HPR800S-000295 or earlier has this PCB	PCB2	1
	108028	Fuse: 3 amp, 250 volt	F5, F6, F7	3
	108075	Fuse: 6.3 amp, 250 volt (slow-blow)	F1, F2, F3	3
	108709	Fuse: 10 amp, 250 volt	F4	1
	229339	Non-Eco design wire harness		1
3	10078615	Eco Design PCB: Power distribution A power supply with serial number HPR800P-010001 or HPR800S-010001 or later has this PCB	PCB2	1
	108028	Fuse: 3 amp, 250 volt	F5, F6, F7	3
	108075	Fuse: 6.3 amp, 250 volt (slow-blow)	F1, F2, F3	3
	108709	Fuse: 10 amp, 250 volt	F4	1
	10081508	Eco Wire harness – Necessary with the 10078615 power distribution PCB*		1
4	141030	PCB: Control (Primary power supply)	PCB3	1
4	141144	PCB: Control (Second power supply)	PCB3	1
5	027079	10" fan: 450-550 CFM, 120 VAC 50-60 HZ		3
6	229225	Control transformer: 400 volt, 50-60 HZ	T2	1
	229226	Control transformer: 380 volt, 50-60 HZ		1
	229227	Control transformer: 480 volt, 60 HZ		1
	229228	Control transformer: 600 volt, 60 HZ		1
	229230	Control transformer: 240 volt, 60 HZ		1
	229231	Control transformer: 200 and 208 volt, 50-60 HZ		1
	229232	Control transformer: 440 volt, 50-60 HZ		1
	229233	Control transformer: 220 volt, 50-60 HZ		1

* You need the 10081508 wire harness to make connections between the 10078615 power distribution PCB and the 141030 control PCB. The 229339 wire harness is not compatible with the 10078615 power distribution PCB.

Chiller

Note: See the chiller manufacturer manual for part numbers.

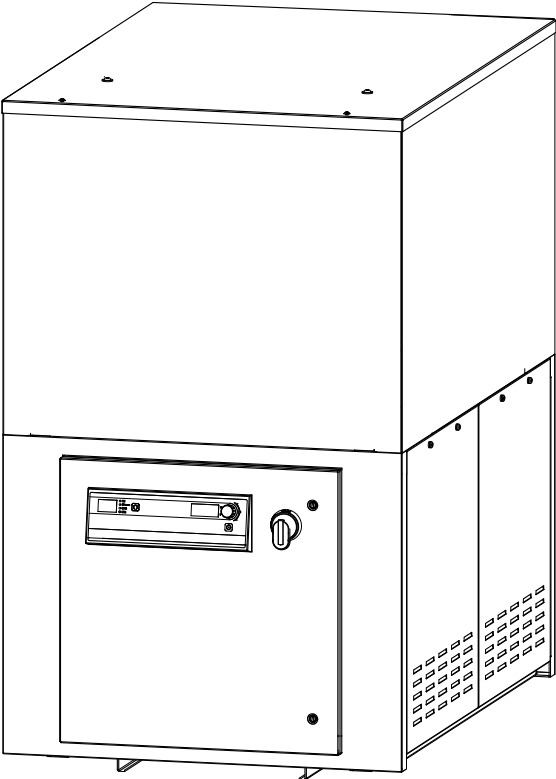

Chiller interface console

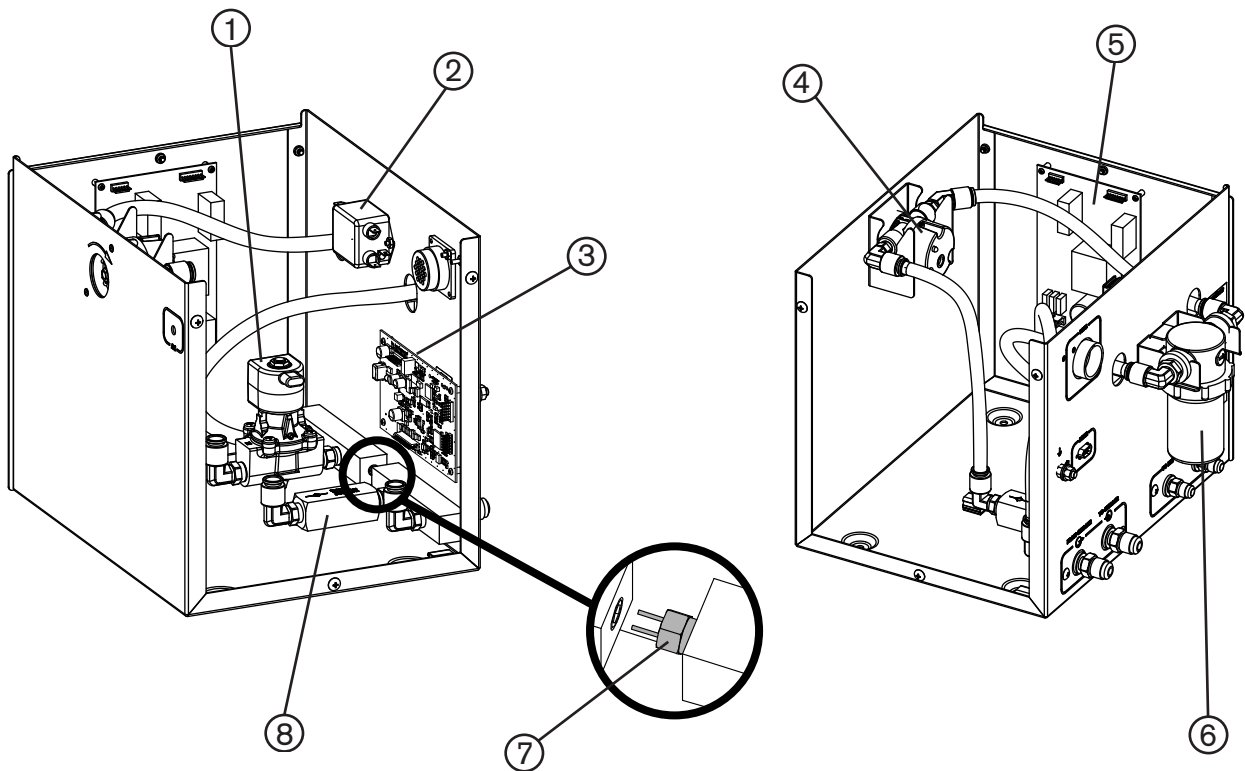

<u>Item</u>	<u>Part Number</u>	<u>Description</u>	<u>Designator</u>	<u>Qty.</u>
	078537	Chiller interface console		
1	229345	Solenoid valve		1
2	009040	EMI filter: 250 VAC, 2 amp, 1 phase		1
3	141033	PCB: Cooler sensor		1
4	229235	Flow sensor	FS1	1
5	041897	PCB: Console power distribution		1
	008756	Fuse: 5 amp, 250 volt (slow-blow)		1
6	027634	Filter housing		1
	027664	Filter element		1
7	229224	Temperature sensor	TS1	1
8	006113	Check valve		1

PARTS LIST

Ignition console

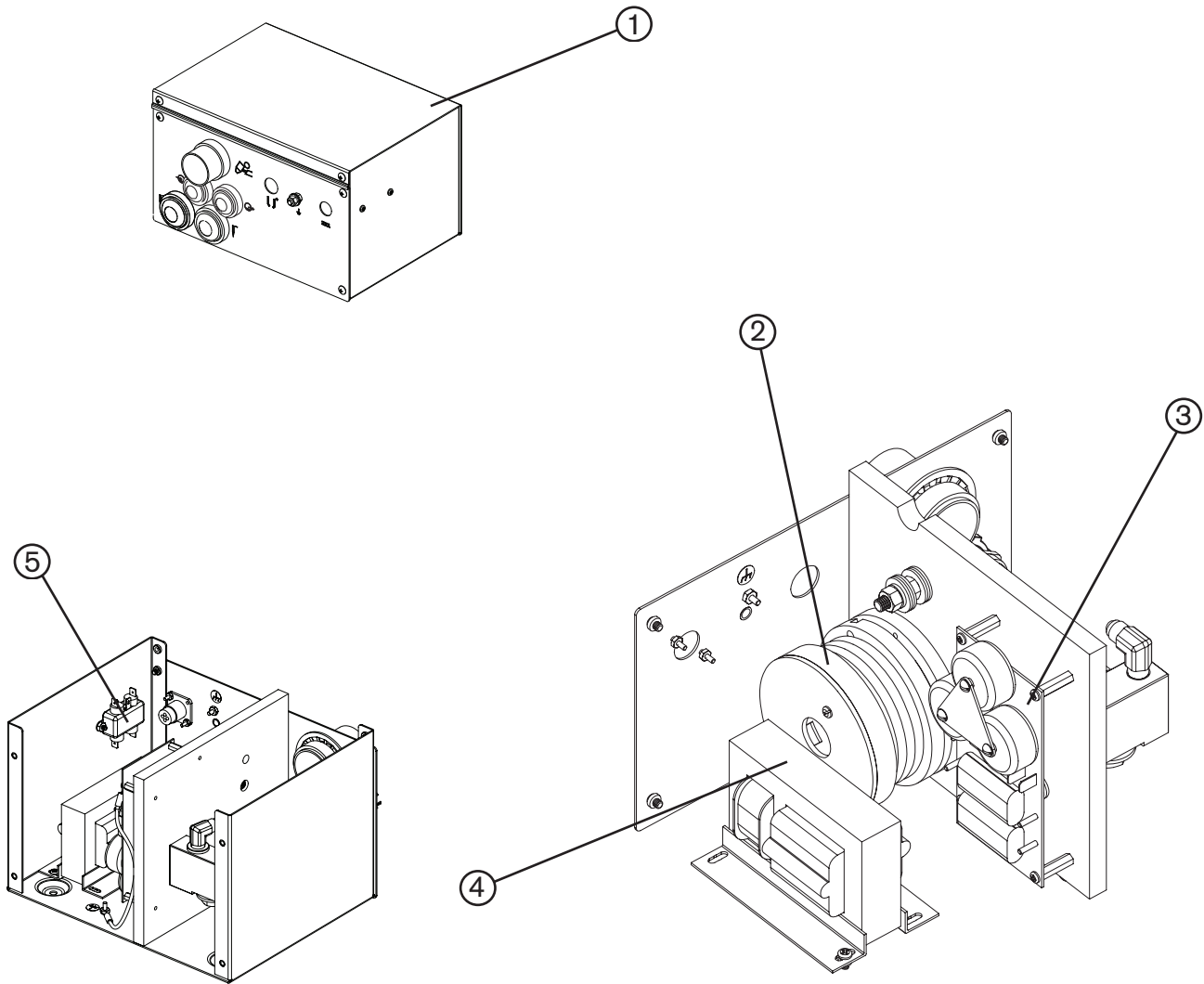

<u>Item</u>	<u>Part Number</u>	<u>Description</u>	<u>Designator</u>	<u>Qty.</u>
1	078536	Ignition console		
2	129831	Coil assembly	T2	1
3	041817	HFHV Ignition PCB	PCB IGN	1
4	129854	Transformer	T1	1
5	009045	EMI filter		1

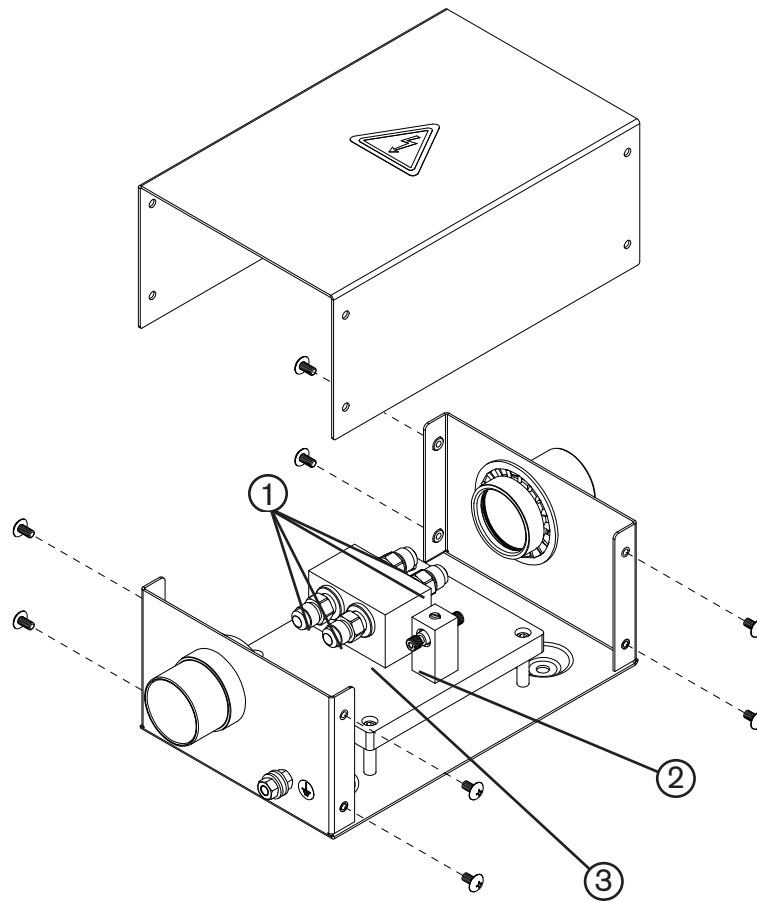
Torch lead junction box (Optional)

Item	Part Number	Description	Qty.
	078619	HPRXD junction box	1
1	015007	Coolant fitting	4
2	104763	Pilot arc fitting	1
3	104762	Coolant block	1

PARTS LIST

Ignition console to junction box leads

Caution: Total lead length from the ignition console to the torch must be less than or equal to:
20 m (65 feet) for HPR130XD / HPR260XD
15 m (50 feet) for HPR400XD / HPR800XD



Part no.	Description	Part no.	Description
428420	3 m (10 ft)	428425	10 m (35 ft)
428421	4.5 m (15 ft)	428426	12.2 m (40 ft)
428339	5.5 m (18 ft)	428427	13.7 m (45 ft)
428422	6 m (20 ft)	428428	15 m (50 ft)
428423	7.5 m (25 ft)	428429	16.8 m (55 ft)
428424	9.1 m (30 ft)		

Selection console

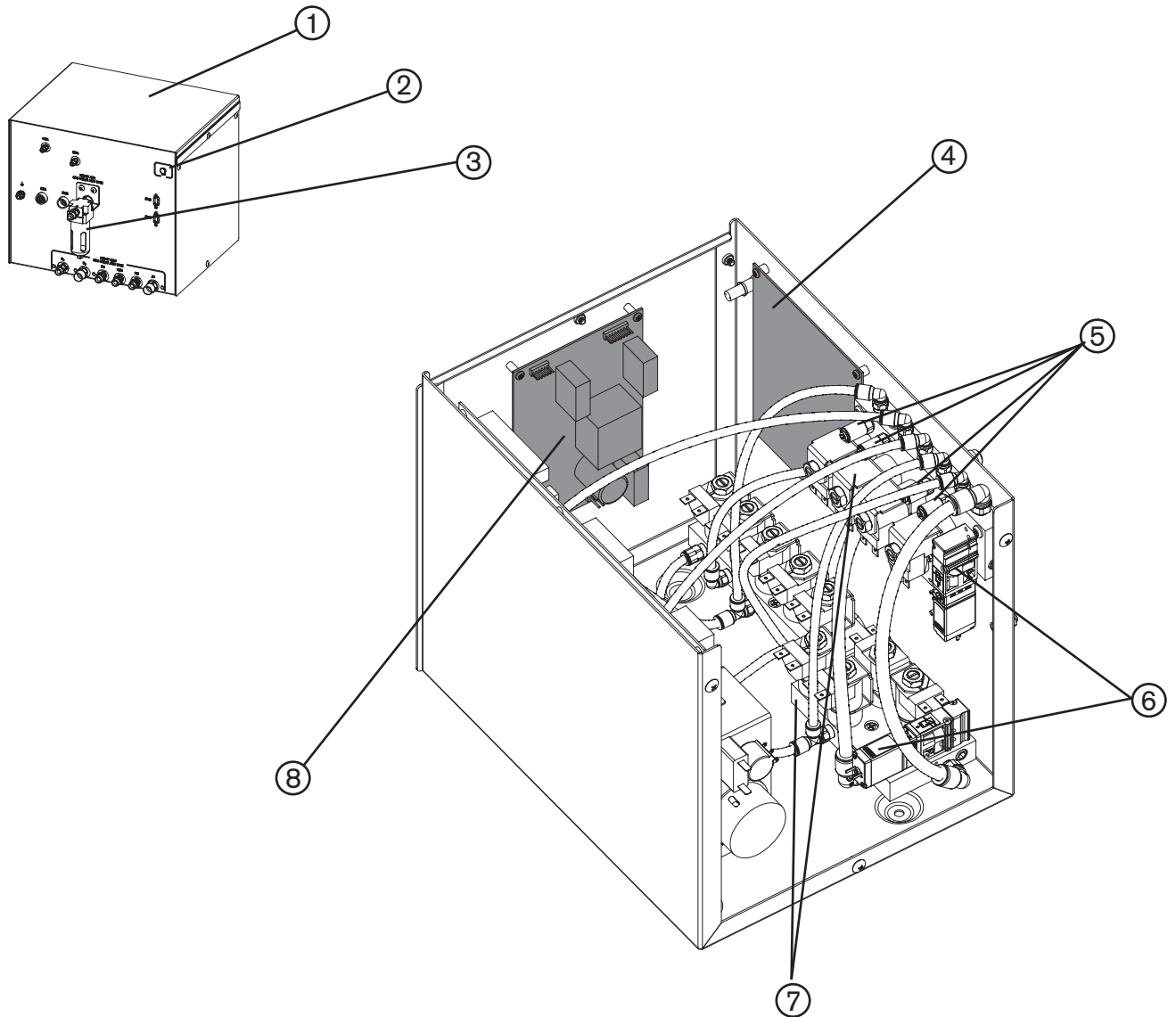

<u>Item</u>	<u>Part Number</u>	<u>Description</u>	<u>Designator</u>	<u>Qty.</u>
1	078533	Selection console		
2	129633	Green power lamp		1
3	011109	Filter assembly		1
	011110	Filter element		1
4	228069	Kit: Control PCB	PCB2	1
5	005263	Pressure sensor	P1 – P4	4
	123780	Pressure sensor wire harness	P1 – P4	1
6	228984	Solenoid valve	SV3 and SV10	2
7	006109	Solenoid valve	SV1 and SV2, SV4–SV9, SV11–SV15	13
8	041897	Power distribution PCB	PCB1	1
	008756	Fuse: 5A, 250V, slow blow	F1	1

PARTS LIST

Selection console

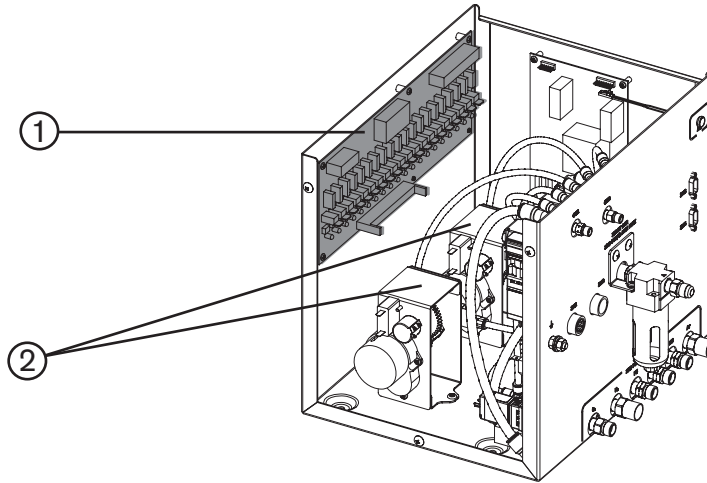

<u>Item</u>	<u>Part Number</u>	<u>Description</u>	<u>Designator</u>	<u>Qty.</u>
1	041822	Valve driver PCB	PCB3	1
	008756	Fuse: 5 A, 250V, slow-blow	F1	1
2	129999	Motor valve assembly	MV1, MV2	2
	229217	Selection console wire harness		1
	228347	Hose kit		1

Metering console

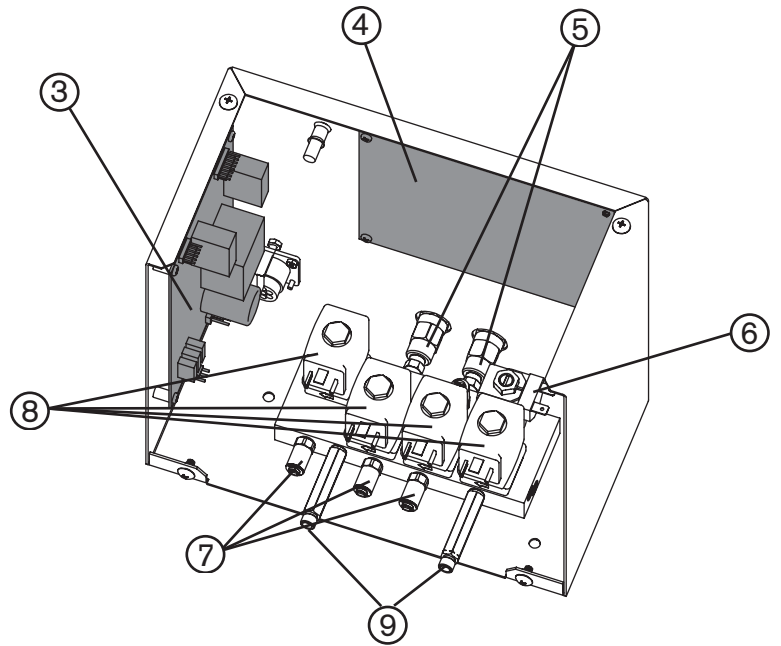
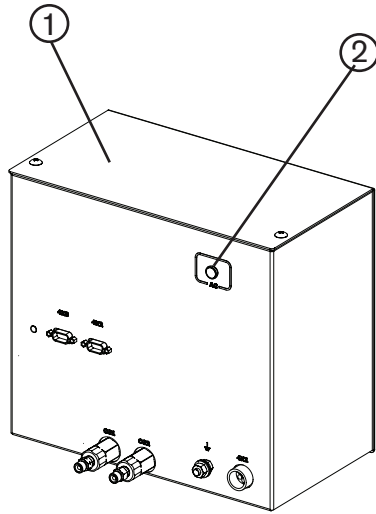

<u>Item</u>	<u>Part Number</u>	<u>Description</u>	<u>Designator</u>	<u>Qty.</u>
1	078535	Metering console		1
2	129633	Green power lamp		1
3	041897	Power distribution PCB	PCB1	1
	008756	Fuse: 5 amp, 250 volt (slow-blow)	F1	1
4	228069	Kit: Control PCB	PCB2	1
5	006077	Check valves		2
6	006109	Solenoid valve	SV16	1
7	005263	Pressure transducer (3 of 4 shown)	P5-P8	4
	123802	Pressure transducer wire harness		1
8	006128*	Proportional valve	B1-B4	4
	228023**	Kit: HPR gas metering manifold upgrade (does not include Item 9)		1
	229032	Metering console wire harness		1
9	Multiple***	Push-to-connect fittings for HPRXD systems		1-2

* Gas consoles with a serial number of 500134 or later take this part number

** Gas consoles with a serial number of 500133 or earlier must order this kit

***When Kit 228023 is used with an HPR130XD, HPR260XD, HPR400XD, or HPR800XD auto gas system, the following parts are also necessary: 104425 (1), 104406 (1), 015634 (2), 015732 (1), and 015731 (1).

PARTS LIST

HyPerformance torch

Torch assembly

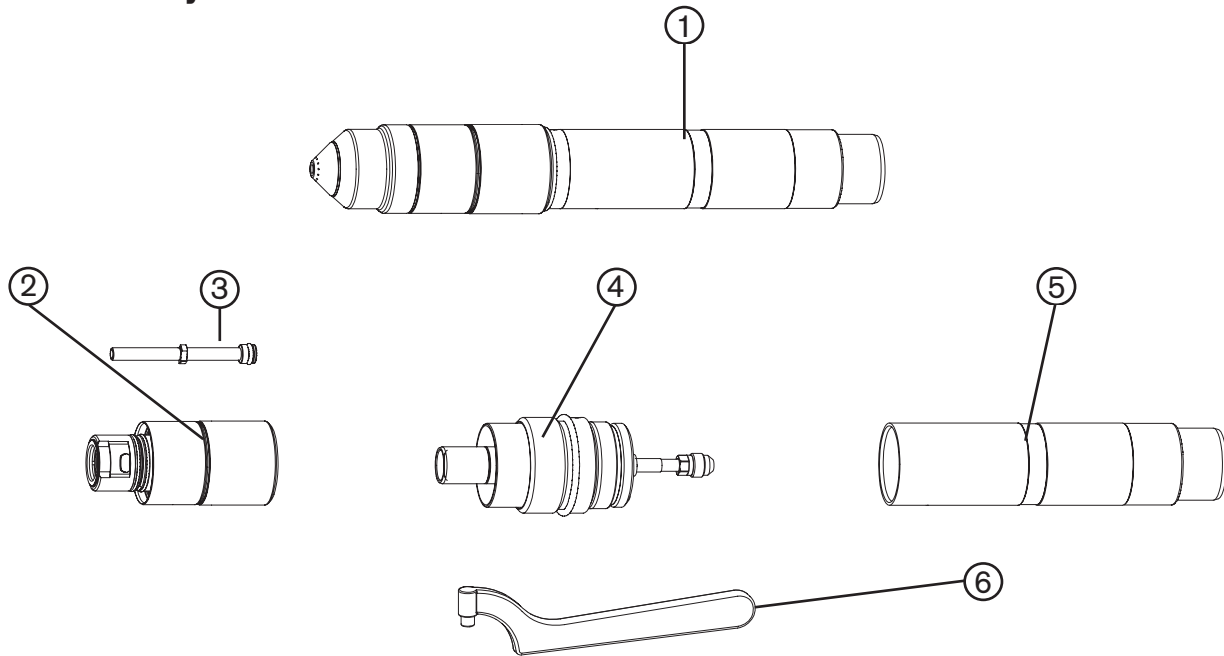

<u>Item</u>	<u>Part Number</u>	<u>Description</u>
1	228599	HPR800XD machine torch assembly
2	220706	Quick-disconnect torch (no water tube)
3	220881	Water tube*
4	220705	Quick-disconnect receptacle
5	220789	Torch mounting sleeve assembly: Standard, 181 mm (7 in)
	220788	Torch mounting sleeve assembly: Short, 114 mm (4.5 in)
	220790	Torch mounting sleeve assembly: Long, 248 mm (9.75 in)
6	104269	2" spanner wrench
	128879	Torch kit: O-rings, water tube and seal
	128880	Quick disconnect kit: O-ring and connector

* Water tube no. 220881 comes in the 228599 torch assembly. See *consumable selection* or the cut charts in the *operation* section of this manual for other water tube part numbers.

Torch leads



With standard 1829 mm (72 in) gas leads	
Part no.	Length
228291	2 m (6 ft)
228292	3 m (10 ft)
228293	4.5 m (15 ft)
228294	6 m (20 ft)
228295	7.5 m (25 ft)
228296	10 m (35 ft)
228297	15 m (50 ft)

With extended 2438 mm (96 in) gas leads	
Part no.	Length
228410	2 m (6 ft)
228411	3 m (10 ft)
228412	4.5 m (15 ft)
228413	6 m (20 ft)
228414	7.5 m (25 ft)
228415	10 m (35 ft)
228416	15 m (50 ft)

Note: A 20 m (65 ft) torch lead is not available for HPR800XD systems

Ohmic contact wire (Not part of the HPR800XD system. Shown for reference only.)

Note: The Ohmic extension wire found in appendix C is for robotic applications only

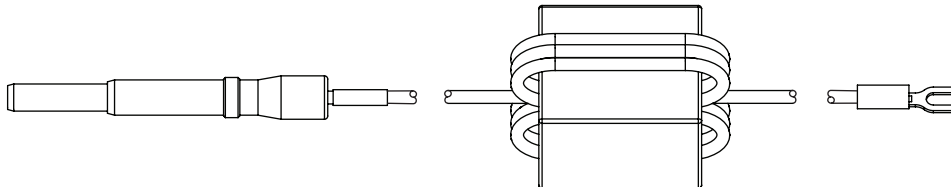

Part no.	Length
123983	3 m (10 ft)
123984	6 m (20 ft)
123985	7.5 m (25 ft)
123986	9 m (30 ft)
123987	12 m (40 ft)
123988	15 m (50 ft)
123989	23 m (75 ft)
123990	30 m (100 ft)
123991	45 m (150 ft)

PARTS LIST

Consumable parts kits

Note: See *Consumable selection* or *Cut charts* in section 4 for specific applications

Mild steel parts kit – 228367

<u>Part Number</u>	<u>Description</u>	<u>Qty.</u>
026009	O-ring: 0.208" X 0.070"	5
027055	Lubricant: Silicone 1/4-oz tube	1
044028	O-ring: 1.364" X 0.070"	2
104119	Tool: Consumable removal / replacement	1
104269	Wrench: Spanner	1
220179	Swirl ring: 80 A/130 A	1
220180	Swirl ring: 30 A	1
220181	Electrode: 130 A	2
220182	Nozzle: 130 A	3
220183	Shield: 130 A	2
220187	Electrode: 80 A	2
220188	Nozzle: 130 A	2
220189	Shield: 80 A	1
220192	Electrode: 30 A	2
220193	Nozzle: 30 A	2
220194	Shield: 30 A	1
220340	Water tube with o-ring	1
220352	Electrode: 200 A	2
220353	Swirl ring: 200 A	1
220354	Nozzle: 200 A	3
220435	Electrode: 260 A	2
220436	Swirl ring: 260 A	1
220439	Nozzle: 260 A	3
220552	Electrode: 50 A	2
220553	Swirl ring: 50 A	1
220554	Nozzle: 50 A	2
220555	Shield: 50 A	1
220571	Water tube with o-ring (bevel)	1
220629	Electrode: 400 A	3
220631	Swirl ring: 400 A	1
220632	Nozzle: 400 A	3
220635	Nozzle retaining cap: 400 A	1
220636	Shield: 400 A	2
220637	Shield cap: 400 A	1
420566	SilverPlus electrode: 80 A	1
220665	SilverPlus electrode: 130 A	1
220666	SilverPlus electrode: 200 A	1
220668	SilverPlus electrode: 260 A	1
420530	SilverPlus electrode: 400 A	1
220747	Shield cap: 130 A	1
220754	Nozzle retaining cap: 30 A	1
220756	Nozzle retaining cap: 130 A	1
220757	Nozzle retaining cap: 200 A	1
220760	Nozzle retaining cap: 260 A	1
220761	Shield: 200 A	2
220764	Shield: 260 A	2

Stainless steel and aluminum parts kit – 228368

<u>Part Number</u>	<u>Description</u>	<u>Qty.</u>
026009	O-ring: 0.208" X 0.070"	5
027055	Lubricant: Silicone 1/4-oz tube	1
044028	O-ring: 1.364" X 0.070"	2
104119	Tool: Consumable removal / replacement	1
104269	Wrench: Spanner	1
220179	Swirl ring: 80 A/130 A mild steel	1
220180	Swirl ring: 30 A mild steel	2
220181	Electrode: 130 A mild steel	1
220197	Nozzle: 130 A stainless steel	2
220198	Shield: 130 A stainless steel	1
220307	Electrode: 130 A stainless steel	4
220337	Nozzle: 80 A stainless steel	2
220338	Shield: 80 A stainless steel	1
220339	Electrode: 80 A stainless steel	4
220340	Water tube with o-ring	1
220342	Swirl ring: 200 A stainless steel	1
220343	Nozzle: 200 A stainless steel	2
220346	Nozzle: 200 A aluminum	1
220405	Swirl ring: 260 A stainless steel/aluminum	1
220406	Nozzle: 260 A stainless steel/aluminum	2
220571	Water tube with o-ring (bevel)	1
220637	Shield cap: 400 A	1
220707	Shield: 400 A stainless steel	2
220708	Nozzle: 400 A stainless steel	3
220709	Electrode: 400 A stainless steel	3
220712	Nozzle retaining cap: 400 A stainless steel	1
220747	Shield cap: 130 A	1
220755	Nozzle retaining cap: 130 A CCW	1
220756	Nozzle retaining cap: 130 A mild steel, CW	1
220758	Nozzle retaining cap: 260 A stainless steel	1
220759	Nozzle retaining cap: 200 A aluminum	1
220762	Shield: 200 A stainless steel	1
220763	Shield: 260 A stainless steel/aluminum	1
220814	Nozzle retaining cap: 60 A HDi	1
220815	Shield: 60 A HDi, stainless steel	1
220847	Nozzle: 60 A HDi, stainless steel	2

PARTS LIST

Consumable parts kits

Note: See *Consumable selection* or *Cut charts* in section 4 for specific applications

Stainless steel and aluminum parts kit (600 amps and 800 amps) – 228603

<u>Part Number</u>	<u>Description</u>	<u>Qty.</u>
026009	O-ring: 5.28 mm (0.208") X 1.78 mm (0.070")	5
027055	Lubricant: Silicone 1/4-oz tube	1
044028	O-ring: 34.65 mm (1.364") X 1.78 mm (0.070")	2
104119	Tool: Consumable removal / replacement	1
104269	Wrench: Spanner	1
220350	Swirl ring: 200 A	1
220353	Swirl ring: 200 A	1
220405	Swirl ring: 260 A	1
220571	Water tube with o-ring (bevel)	1
220635	Nozzle retaining cap: 400 A	1
220637	Shield cap: 400 A	2
220707	Shield: 400 A	1
220709	Electrode: 400 A	2
220712	Nozzle retaining cap: 400 A	1
220859	Nozzle: 600 A	2
220881	Water tube with o-ring	1
220882	Electrode: 800 A	6
220884	Nozzle: 800 A	6
220885	Nozzle retaining cap: 800 A	1
220886	Shield: 800 A	2
880721	Torch brochure: HPR800XD	1

Consumables for mirror-image cutting

Straight cutting

Mild steel

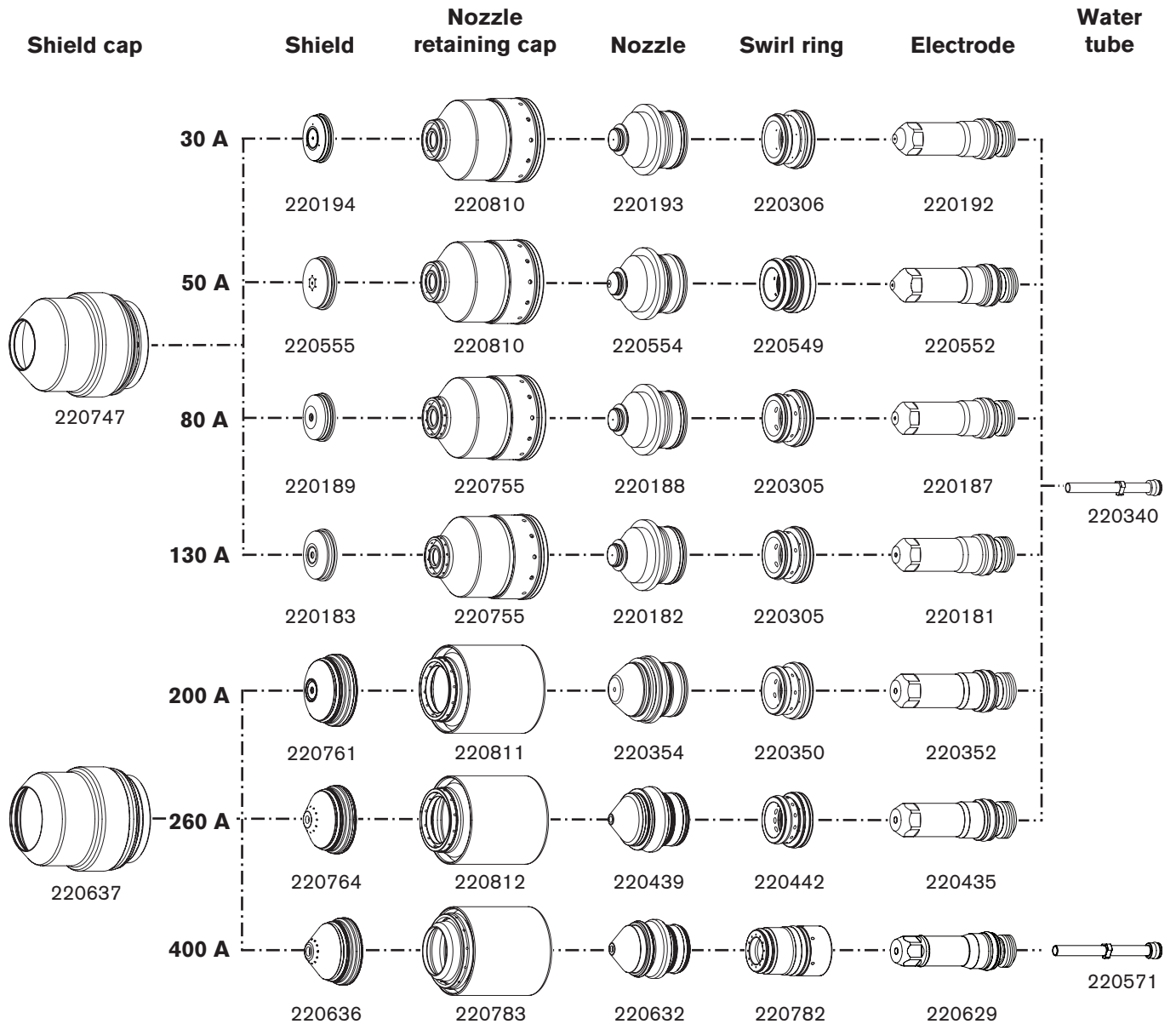

PARTS LIST

Stainless steel

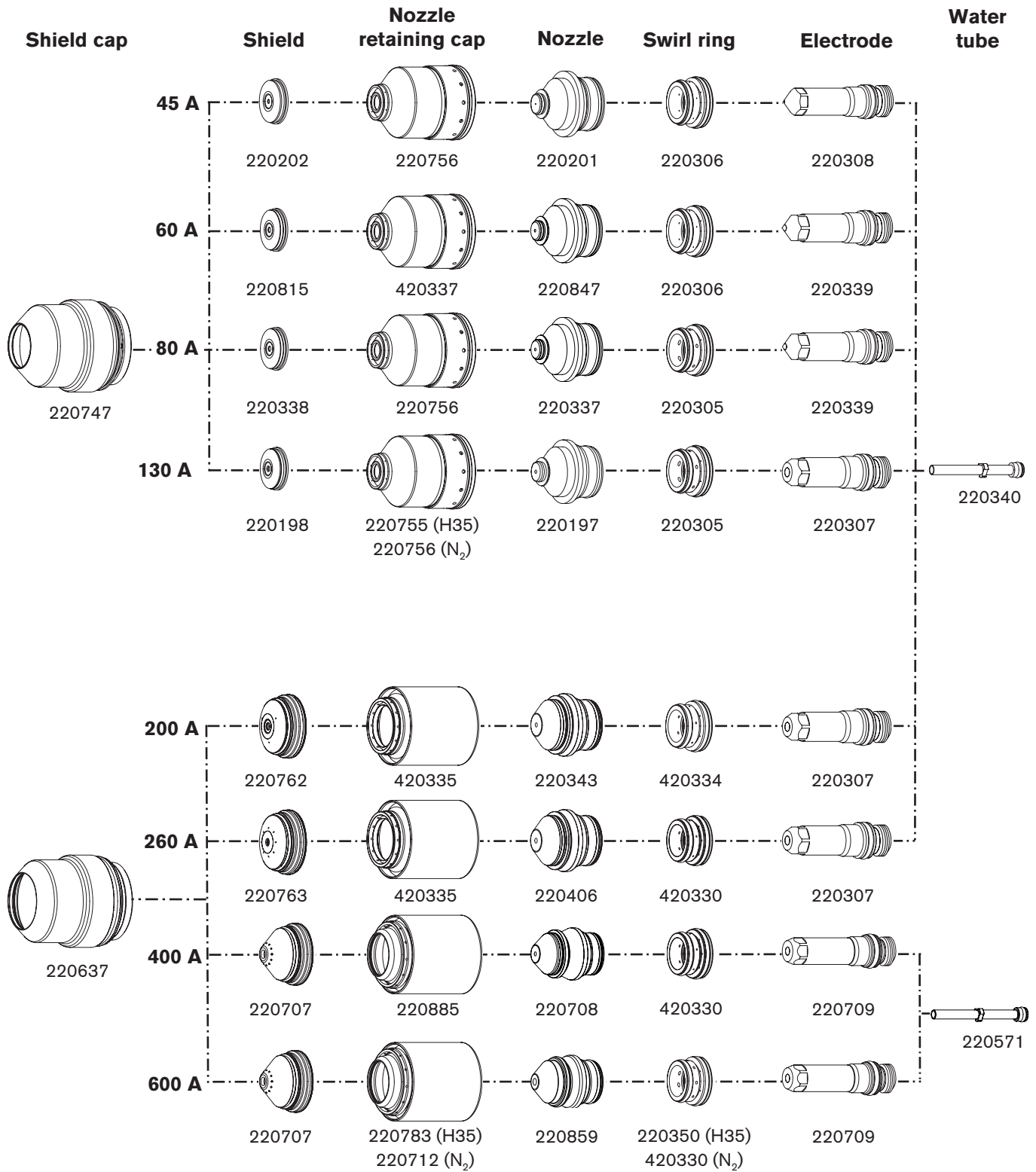

Stainless steel

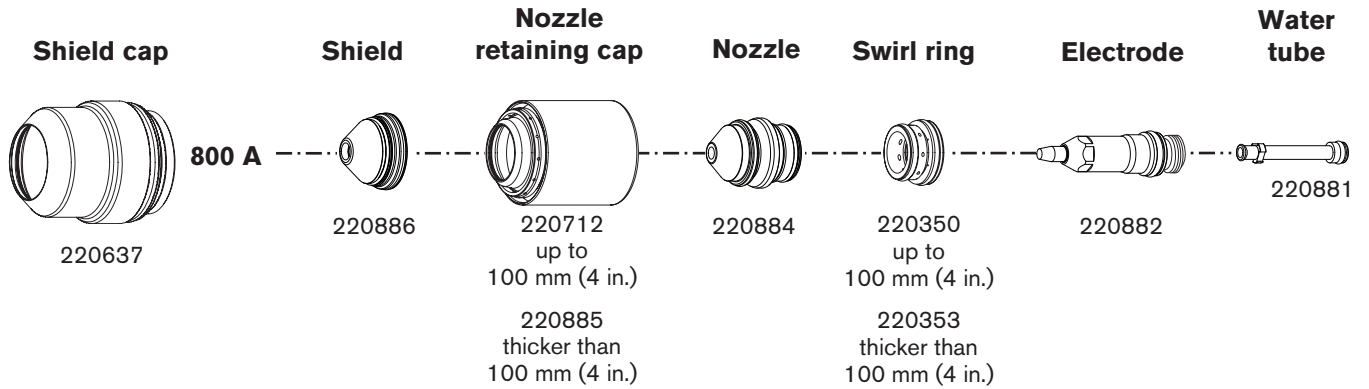

Bevel cutting

Mild steel

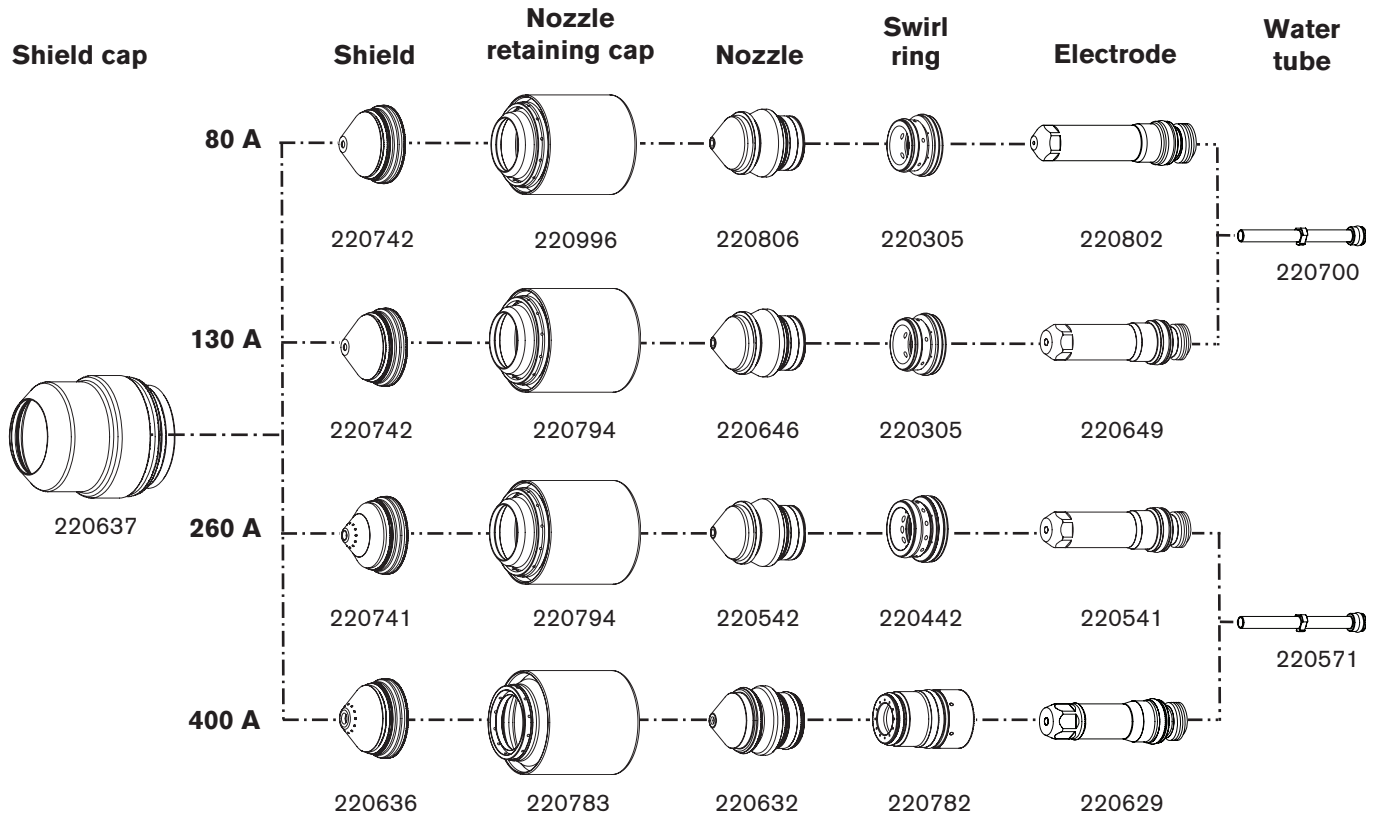

PARTS LIST

Stainless steel

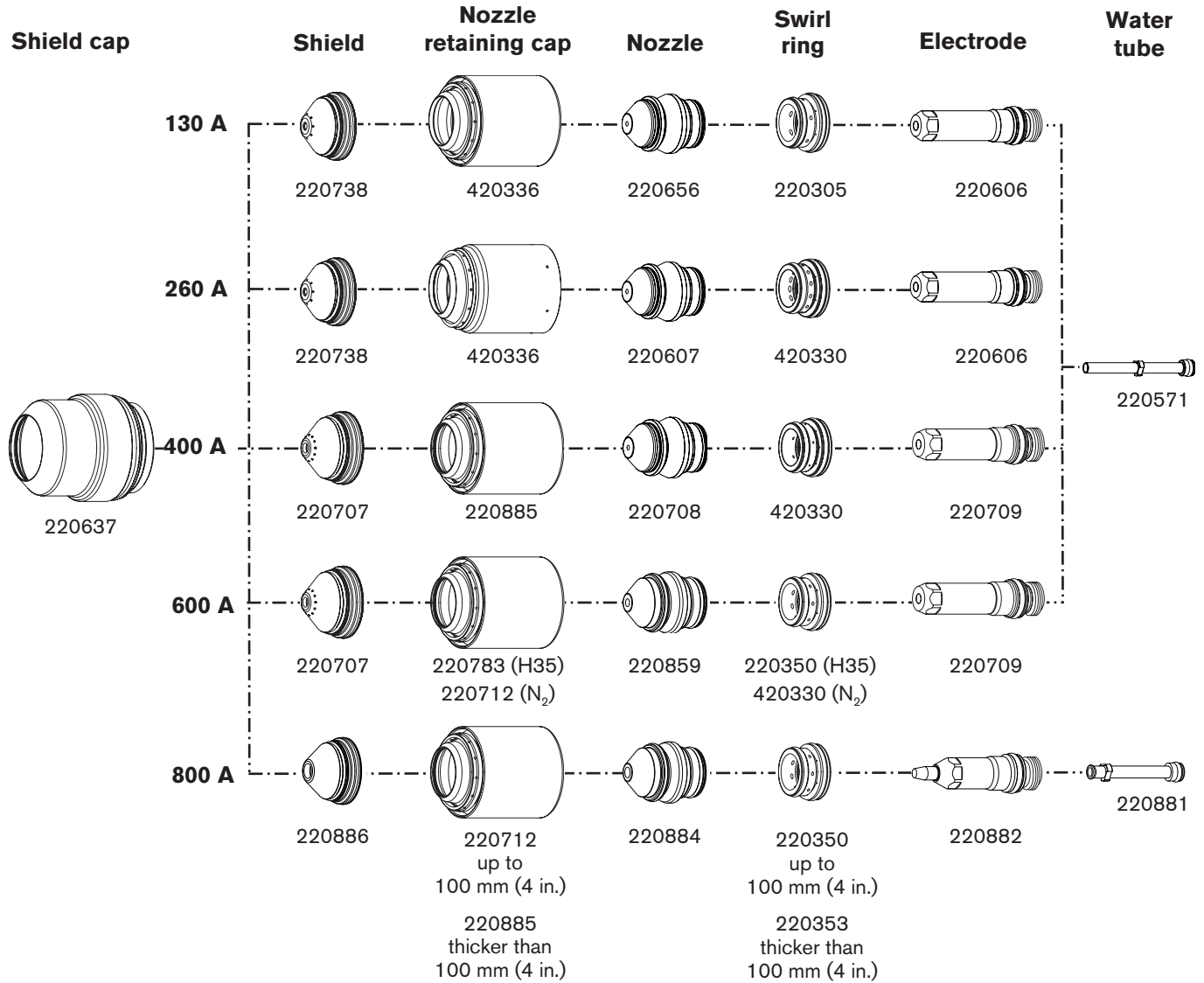

Recommended spare parts

Power supply

<u>Part Number</u>	<u>Description</u>	<u>Designator</u>	<u>Qty.</u>
003142	Relay: 120 volt, double pole, double throw	K1	1
128858	Green power lamp assembly		1
129792	Chopper assembly	CH1, CH2, CH3, CH4	1
127039	6" fan: 230 CFM, 115 VAC 50-60 HZ		1
027079	10" fan: 450-550 CFM, 120 VAC 50-60 HZ		1
003149	Relay: Pilot arc, 120 VAC	CR1	1
229213	PCB: I/O		1
003218*	Contactora	CON1	1
003233**	Contactora	CON1	1
109004	Current sensor: Hall 100 amp, 4 volt	CS1, CS2, CS3, CS4	1
229238	Start circuit assembly	PCB1	1
008709*	Fuse: 20 amp, 500 volt	F1, F2	2
108847**	Fuse: 7.5 amp, 600 volt	F1, F2	2
141030	PCB: Control (Primary power supply)	PCB3	1
141144	PCB: Control (Secondary power supply)	PCB3	1
10078615	PCB: ECO Design Power distribution	PCB2	1
041802	PCB: Power distribution	PCB2	1
108028***	Fuse: 3 amp, 250 volt	F5, F6, F7	3
108075***	Fuse: 6.3 amp, 250 volt (slow-blow)	F1, F2, F3	3
108709***	Fuse: 10 amp, 250 volt	F4	1
141027	PCB: Pump motor drive	PCB7	1
229340	Snubber board		1
229360	Contactora: 500 amp DC 120 VAC COIL	Con2, Con3	2

* 200/208, 220 and 240 volt power supplies

** 380, 400, 440, 480 and 600 volt power supplies

*** This fuse is also used for the ECO power distribution PCB (10078615)

Chiller interface console

<u>Part Number</u>	<u>Description</u>	<u>Designator</u>	<u>Qty.</u>
041897	PCB: Console power distribution		1
008756	Fuse: 5 amp, 250 volt (slow-blow)	F1	1
027634	Filter housing (on the rear panel of the cooler)		1
027664	Filter element		1
229235	Flow sensor	FS1	1
006113	Check valve: 3/8" FPT		1
229345	Solenoid valve		1
141033	PCB: Cooler sensor		1
229224	Temperature sensor		1

PARTS LIST

Chiller

All part numbers, except 038123 and 428892, are for use with the PolyScience chiller. See the manufacturer manual that came with the chiller for a more detailed parts list.

<u>Part Number</u>	<u>Description</u>	<u>Qty.</u>
038123	Chiller:14.3KW, 3PH, 380-400V, 50HZ, 460V, 60HZ	1
428892	Chiller:14.3KW, 3PH, 380-400V, 50HZ, 460V, 60HZ F-Gas	1
040266*	Contactora	1
040276*	Fuse: 30 amp	1
040278*	Fuse: 5 amp	1
040279*	Fuse: 6 amp	1
040275**	Fuse: 3.5 amp	1
040265***	Contactora	1
040273***	Fuse: 15 amp	1
040272****	Fuse: 1 amp	1
040274****	Fuse: 2.5 amp	1
040277*****	Fuse: 4 amp	1
040280 (all voltages)	Fuse: 1 amp	1
040267 (all voltages)	Contactora	1
040281 (all voltages)	Fuse: transformer 1.4 amp	1
040282 (all voltages)	Fuse: transformer 3.5 amp	1
040270	Fan: 115 volt, 32 CFM	1
040269	Dual float switch	1
040271	Flow switch	1
040298	Recirculation pump: 1/2 HP, 3PH, 50/60HZ (200-240 volt, 380-460 volt)	1
040299	Recirculation pump: 1/2 HP, 3PH, 60HZ (575-600 volt)	1
040296	Process pump: 1 HP, 3PH, 50/60HZ (200-240 volt, 380-460 volt)	1
040297	Process pump: 1 HP, 3PH, 60HZ (575-600 volt)	1
040295	Valve: Pressure relief valve, 200 psi	1
040301	Sensor: Water pressure transducer	1
040284	Motor: fan, 1140 rpm (200-240 volt, 380-460 volt)	1
040285	Motor: fan, 1140 rpm (575-600 volt)	1
040312	Air filter	3
040322	"Y" strainer for process	1

Ignition console

<u>Part Number</u>	<u>Description</u>	<u>Designator</u>	<u>Qty.</u>
041817	HFHV Ignition PCB		1
129854	Transformer	T1	1

* 200 and 240 volt units

** 380 and 440 volt units

*** 380, 440, 460, 480, 575, and 600 volt units

**** 575 and 600 volt units only

***** 200, 240, 380, 440, 460, and 480 volt units

Selection and metering consoles

<u>Part Number</u>	<u>Description</u>	<u>Designator</u>	<u>Qty.</u>
228069	Kit: Control PCB	PCB2	1
041897	Power distribution PCB	PCB1	1
008756	Fuse: 5 amp, 250 volt (slow-blow)	F1	1
041822	Valve driver PCB	PCB3	1
008756	Fuse: 5 amp, 250 volt (slow-blow)	F1	1
228984	Solenoid valve	SV3 and SV10	2
006109	Solenoid valve	SV1, SV2, SV4-SV9, SV11-SV15	4
005263	Pressure sensor		1
011109	Air filter housing (on the rear panel of the selection console)		1
011110	Air filter element		1

Warning Label – 110647

This warning label is affixed to some power supplies. It is important that the operator and maintenance technician understand the intent of these warning symbols as described. The numbered text corresponds to the numbered boxes on the label.



1. Cutting sparks can cause explosion or fire.
 - 1.1 Do not cut near flammables.
 - 1.2 Have a fire extinguisher nearby and ready to use.
 - 1.3 Do not use a drum or other closed container as a cutting table.
2. Plasma arc can injure and burn; point the nozzle away from yourself. Arc starts instantly when triggered.
 - 2.1 Turn off power before disassembling torch.
 - 2.2 Do not grip the workpiece near the cutting path.
 - 2.3 Wear complete body protection.
3. Hazardous voltage. Risk of electric shock or burn.
 - 3.1 Wear insulating gloves. Replace gloves when wet or damaged.
 - 3.2 Protect from shock by insulating yourself from work and ground.
 - 3.3 Disconnect power before servicing. Do not touch live parts.
4. Plasma fumes can be hazardous.
 - 4.1 Do not inhale fumes.
 - 4.2 Use forced ventilation or local exhaust to remove the fumes.
 - 4.3 Do not operate in closed spaces. Remove fumes with ventilation.
5. Arc rays can burn eyes and injure skin.
 - 5.1 Wear correct and appropriate protective equipment to protect head, eyes, ears, hands, and body. Button shirt collar. Protect ears from noise. Use welding helmet with the correct shade of filter.
6. Become trained. Only qualified personnel should operate this equipment. Use torches specified in the manual. Keep non-qualified personnel and children away.
7. Do not remove, destroy, or cover this label. Replace if it is missing, damaged, or worn.

WIRING DIAGRAMS

Introduction

This section contains the wiring diagrams for the system. When tracing a signal path or referencing with the *Parts List* or **Troubleshooting** sections, please be aware of the following format to assist you in understanding the wiring diagrams' organization:

- Sheet numbers are located in the lower right-hand corner.
- Page-to-page referencing is done in the following manner:

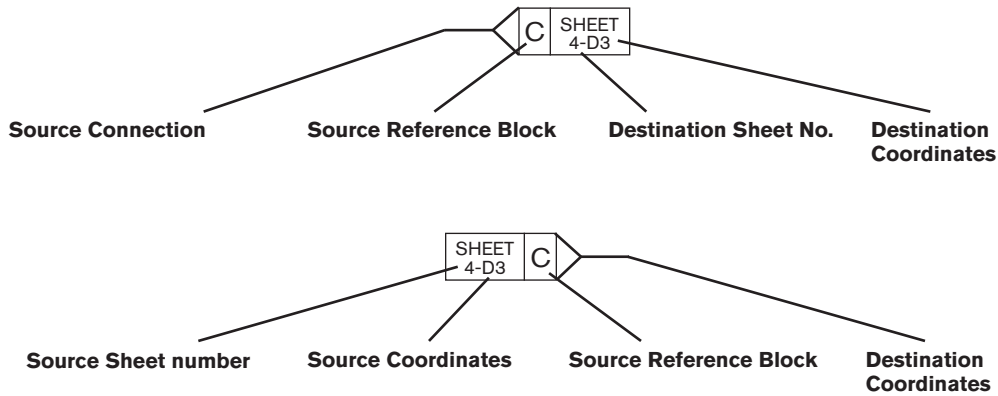

















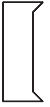

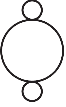

























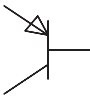

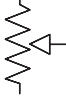





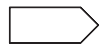

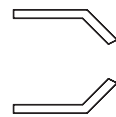



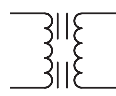
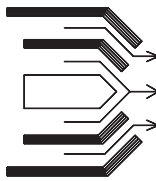

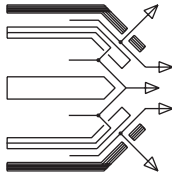

Destination and **Source Coordinates** refer to letters A-D on the Y-axis of each sheet and numbers 1-4 on the X-axis of each sheet. Lining up the coordinates will bring you to the source or destination blocks (similar to a road map).

Wiring diagram symbols

Wiring diagram symbols and their identification precede the system wiring diagrams in this section.

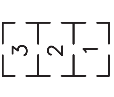
WIRING DIAGRAMS

	Battery		Fuse		Push Button, Normally Closed
	Cap, polarized		Ground Clamp		Push Button, Normally Open
	Cap, non-polarized		Ground, Chassis		Receptacle
	Cap, feed-thru		Ground, Earth		Relay, Coil
	Circuit breaker		IGBT		Relay, Normally Closed
	Coax shield		Inductor		Relay, Normally Open
	Current Sensor		LED		Relay, Solid State, AC
	Current sensor		Lamp		Relay, Solid State, DC
	DC supply		MOV		Relay, Solid State, Dry
	Diode		Pin		Resistor
	Door interlock		Socket		SCR
	Fan		Plug		Shield
	Feedthru LC		PNP Transistor		Shunt
	Filter, AC		Potentiometer		Spark Gap

	Switch, Flow		Time Delay Open, NC/On		Electrode
	Switch, Level, Normally Closed		Time Delay Closed, NO/Off		Nozzle
	Switch, Pressure, Normally Closed		Transformer		Shield
	Switch, Pressure, Normally Open		Transformer, Air Core		Torch
	Switch, 1 Pole, 1 Throw		Transformer Coil		Torch, HyDefinition™
	Switch, 1 Pole, 2 Throw		Triac		
	Switch, 1 Pole, 1 Throw, Center Off		VAC Source		
	Switch, Temperature, Normally Closed		Valve, Solenoid		
	Switch, Temperature, Normally Open		Voltage Source		
	Terminal Block		Zener Diode		
	Time Delay Closed, NC/Off				
	Time Delay Open, NO/Off				

WIRING DIAGRAMS

Discrete output functionality

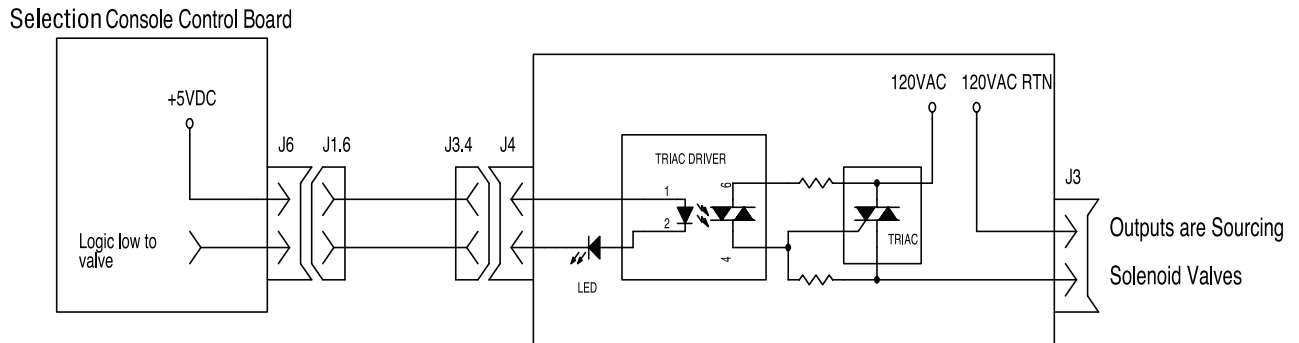
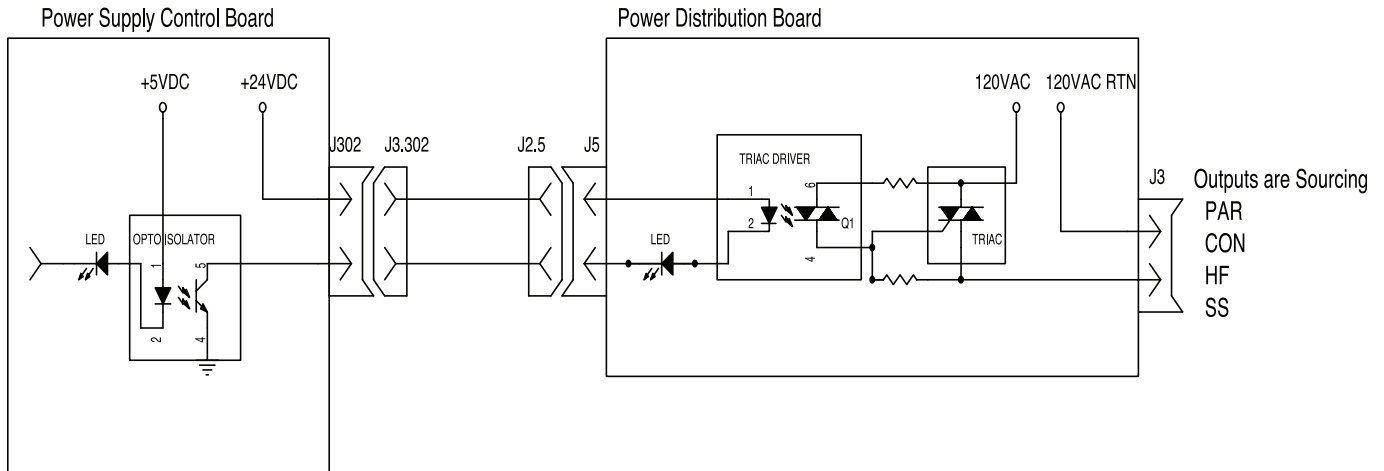

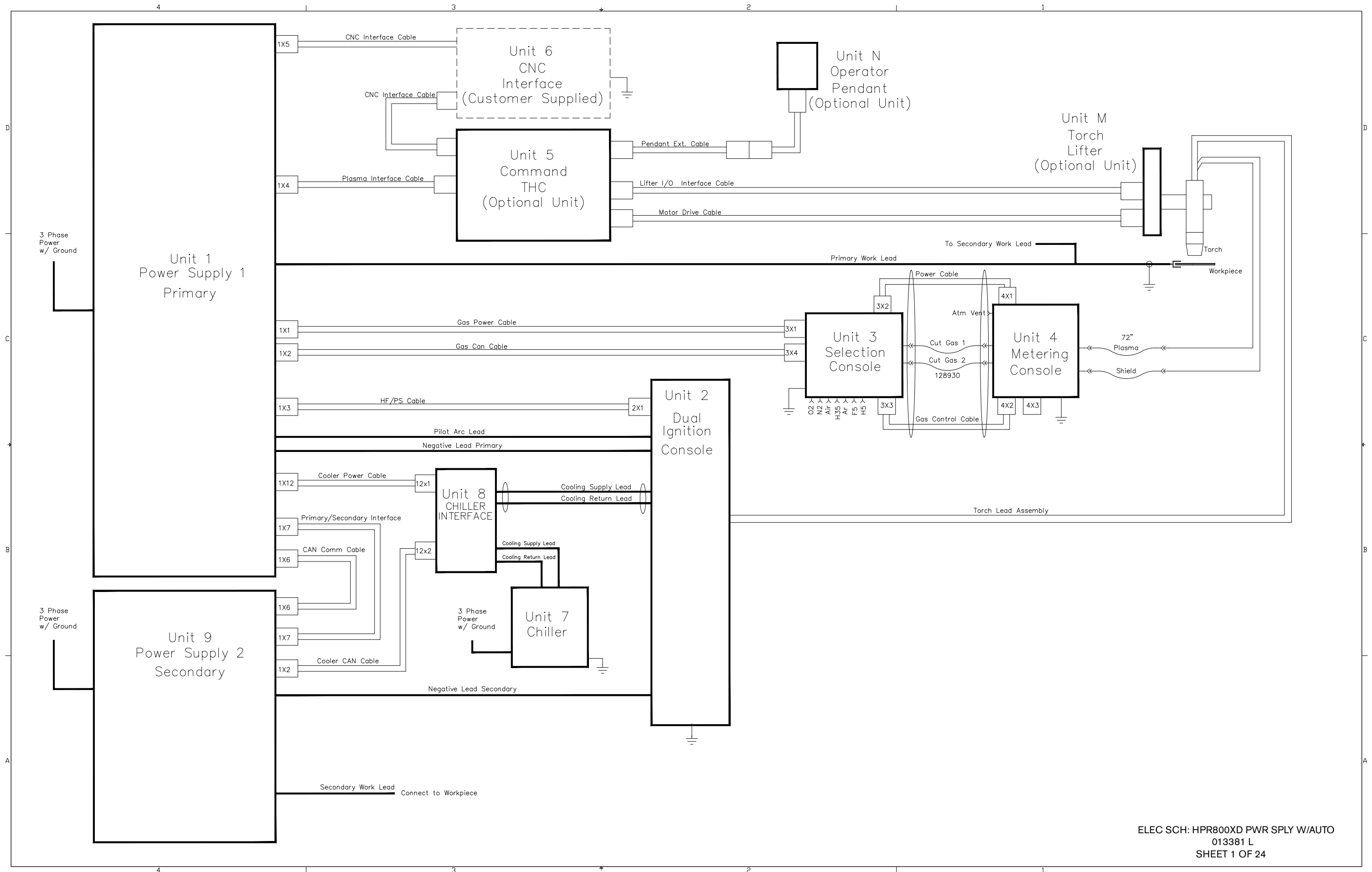

ELEC SCH: HPR800XD PWR SPLY W/AUTO
 013381 L
 SHEET 1 OF 24

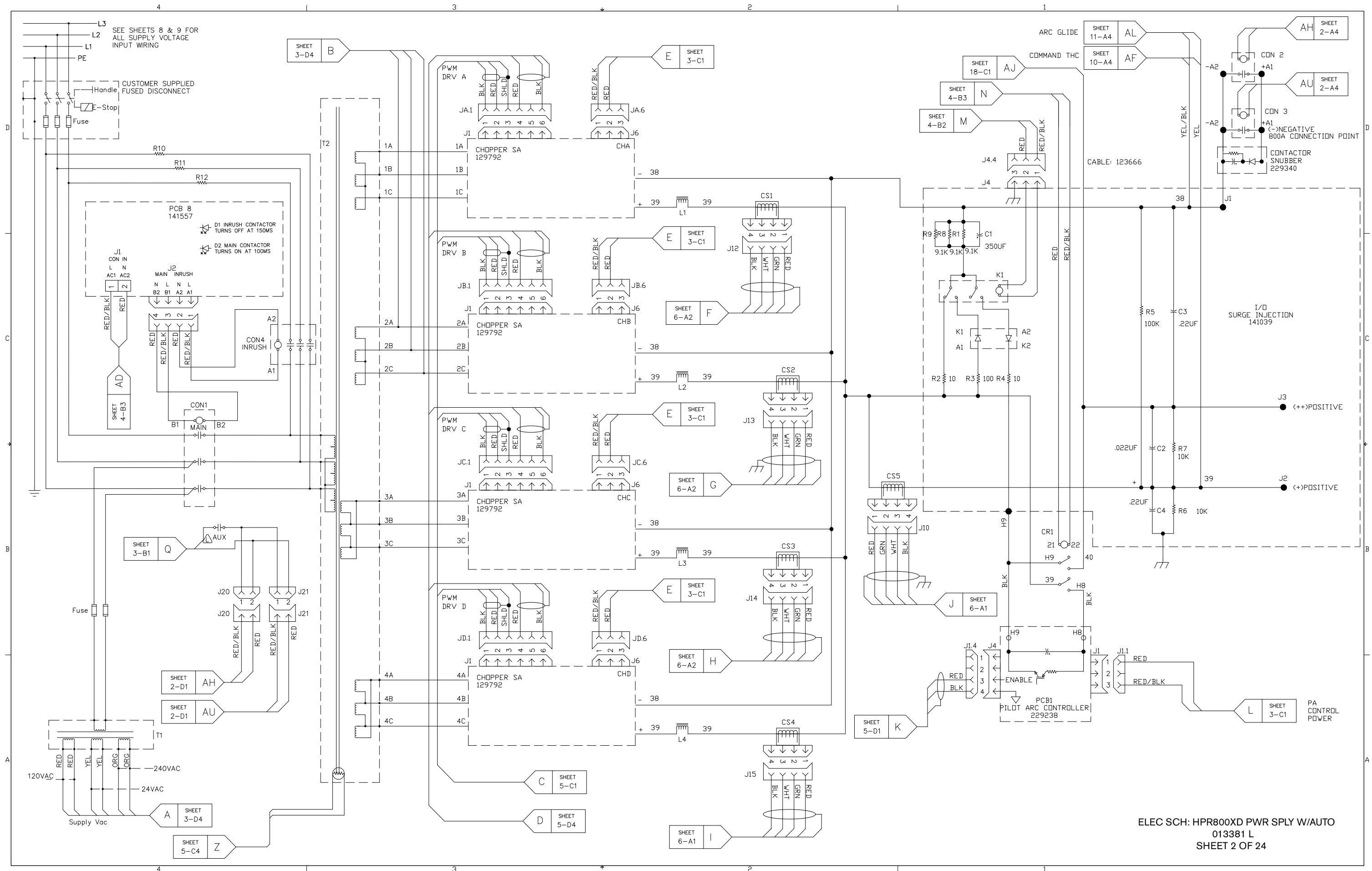

ELEC SCH: HPR800XD PWR SPLY W/AUTO
 013381 L
 SHEET 2 OF 24

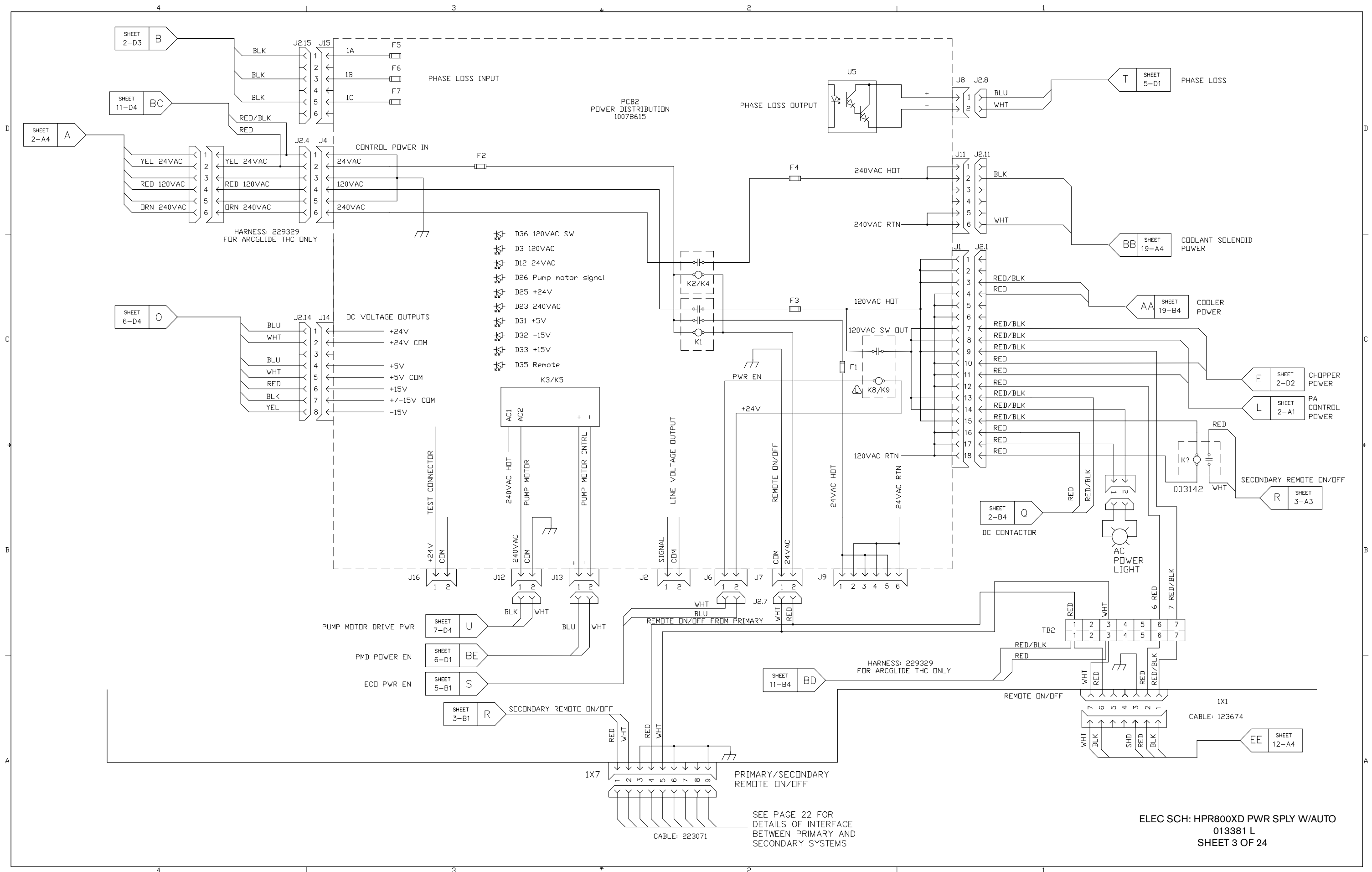

ELEC SCH: HPR800XD PWR SPLY W/AUTO
 013381 L
 SHEET 3 OF 24

4 3 2 1

D

D

C

C

B

B

A

A

PCB2
POWER DISTRIBUTION
10078615

SHEET 5-D1 Y

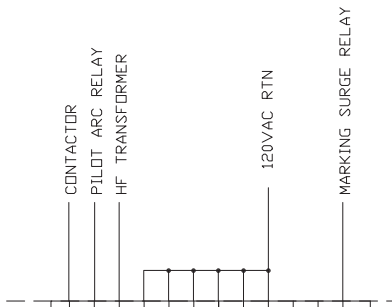
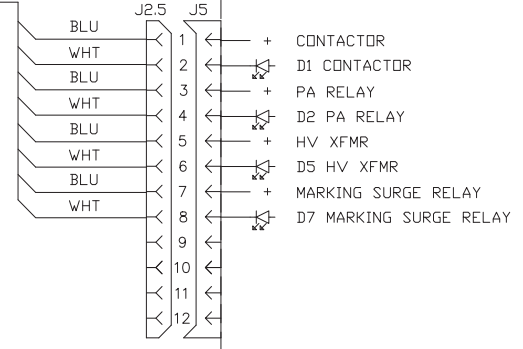

SHEET 2-C4 AD

SHEET 2-D1 N

M SHEET 2-D1



SHEET 18-C4 AC CABLE: 123670

ELEC SCH: HPR800XD PWR SPLY W/AUTO
013381 L
SHEET 4 OF 24

4 3 2 1

PCB3
POWER SUPPLY CONTROL
PRIMARY 141030
SECONDARY 141144

- ⚡ D2 PMD PWR EN
- ⚡ D107 +5V
- ⚡ D108 +3.3V
- ⚡ D110 TXLED
- ⚡ D111 RXLED
- ⚡ D308 MOTION
- ⚡ D309 ERROR
- ⚡ D310 RD ERROR
- ⚡ D311 NOT READY
- ⚡ D312 HOLD IGNITION INPUT
- ⚡ D313 CNC PIERCE COMPLETE INPUT
- ⚡ D314 CNC CORNER CURRENT INPUT
- ⚡ D315 PLASMA START INPUT
- ⚡ D316 PA ENABLE
- ⚡ D317 SPARE
- ⚡ D317 120VAC POWER EN

- ⚡ D320 CONTACTOR
- ⚡ D321 PA RELAY
- ⚡ D322 HF
- ⚡ D323 MARKING SURGE RELAY
- ⚡ D324 PHASE LOSS
- ⚡ D329 PMD OK\
- ⚡ D335 CONTACTOR
- ⚡ D330 MICRO ALARM\

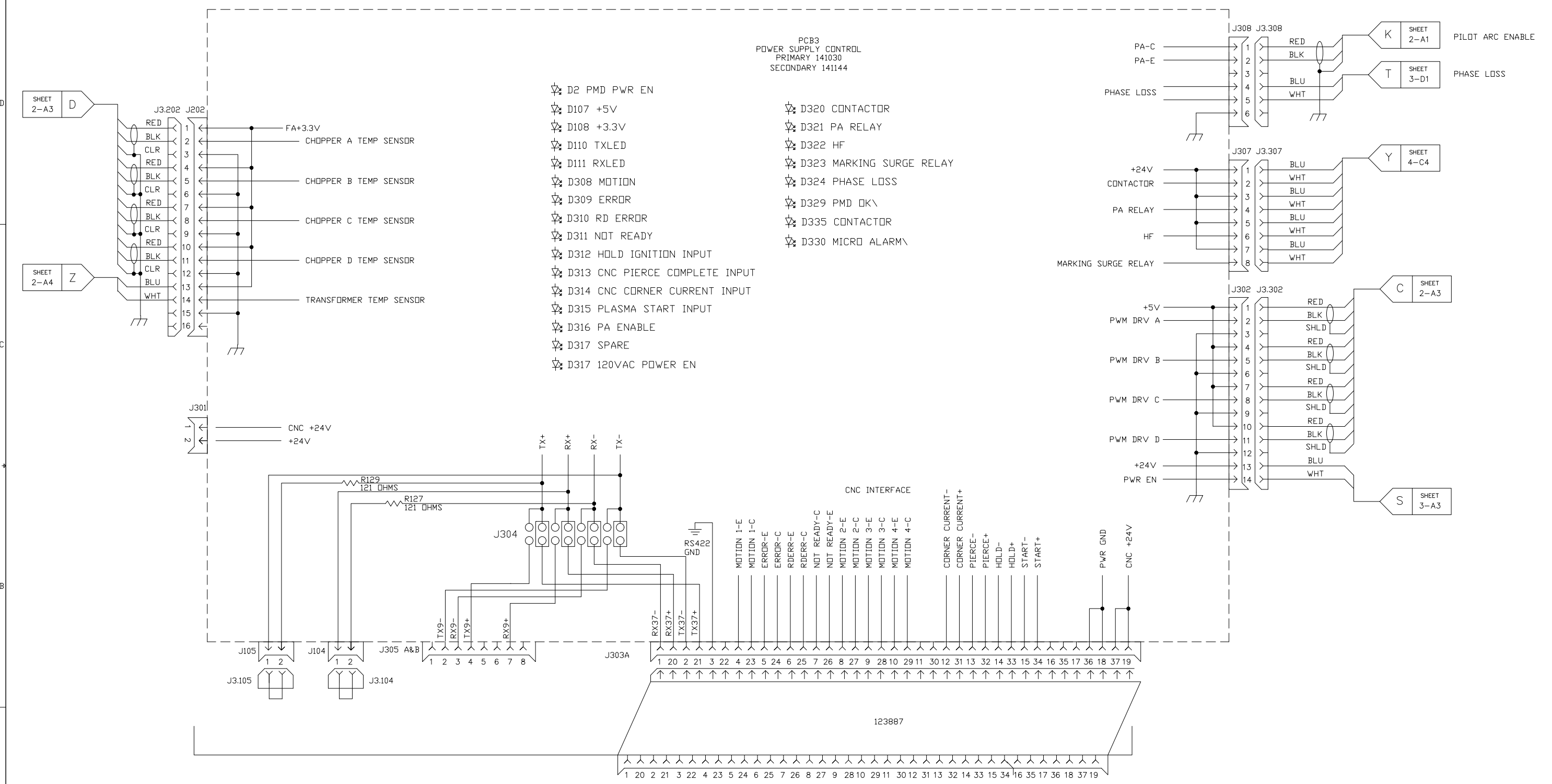

PCB3
POWER SUPPLY CONTROL
PRIMARY 141030
SECONDARY 141144

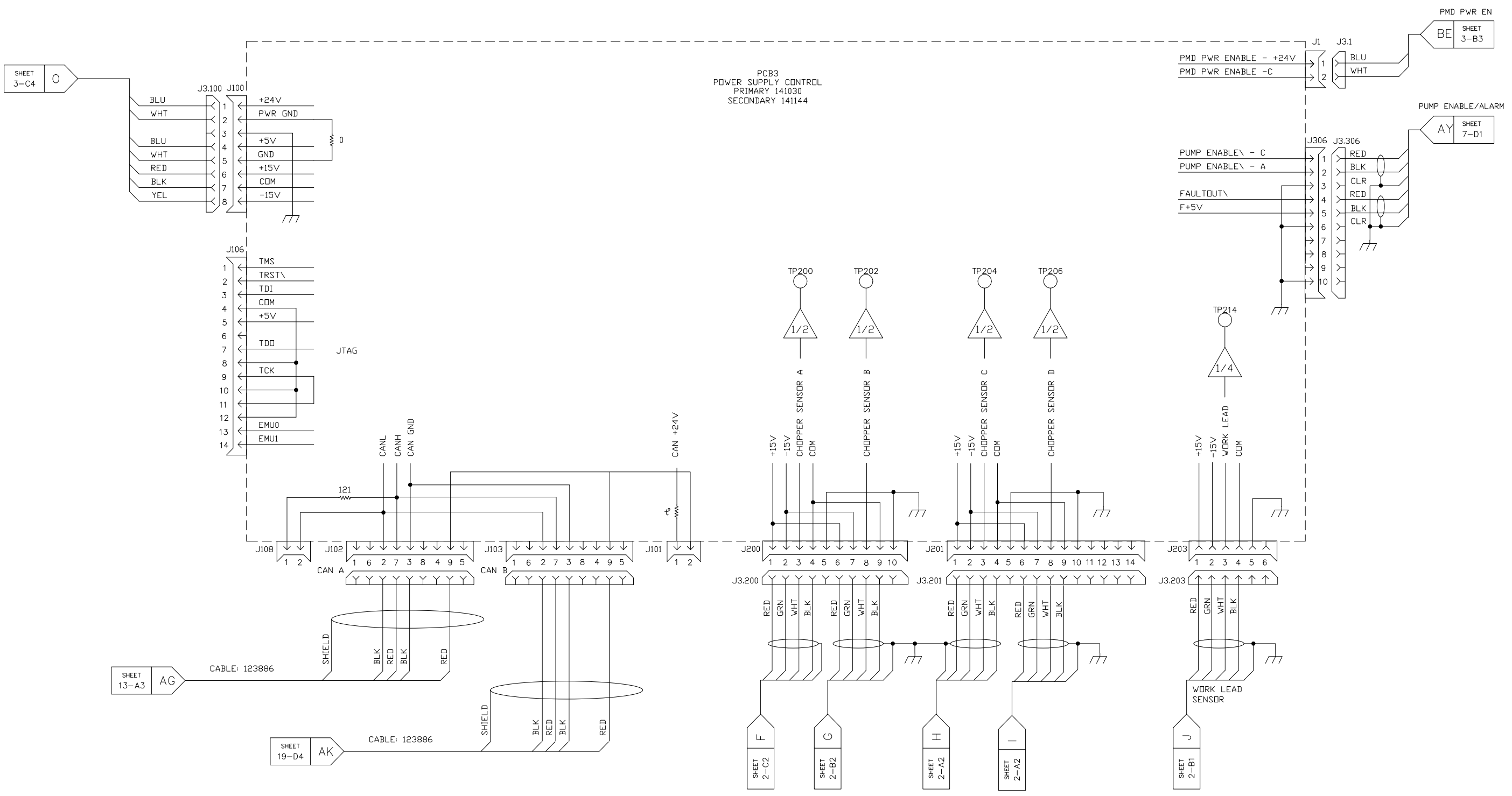

SHEET 3-C4 O

SHEET 13-A3 AG

SHEET 19-D4 AK

PMD PWR EN
BE SHEET 3-B3

PUMP ENABLE/ALARM
AY SHEET 7-D1

ELEC SCH: HPR800XD PWR SPLY W/AUTO
013381 L
SHEET 6 OF 24

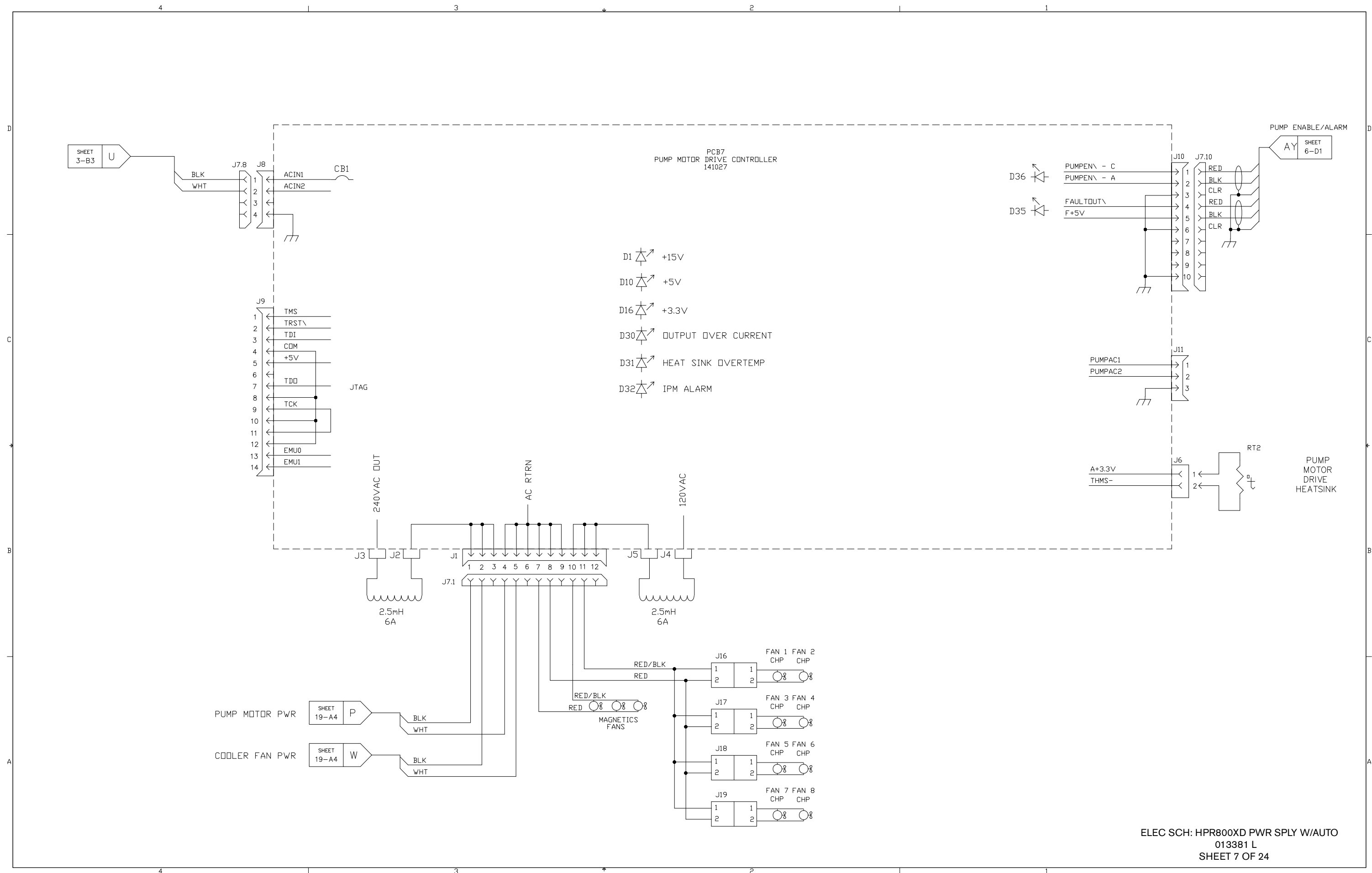

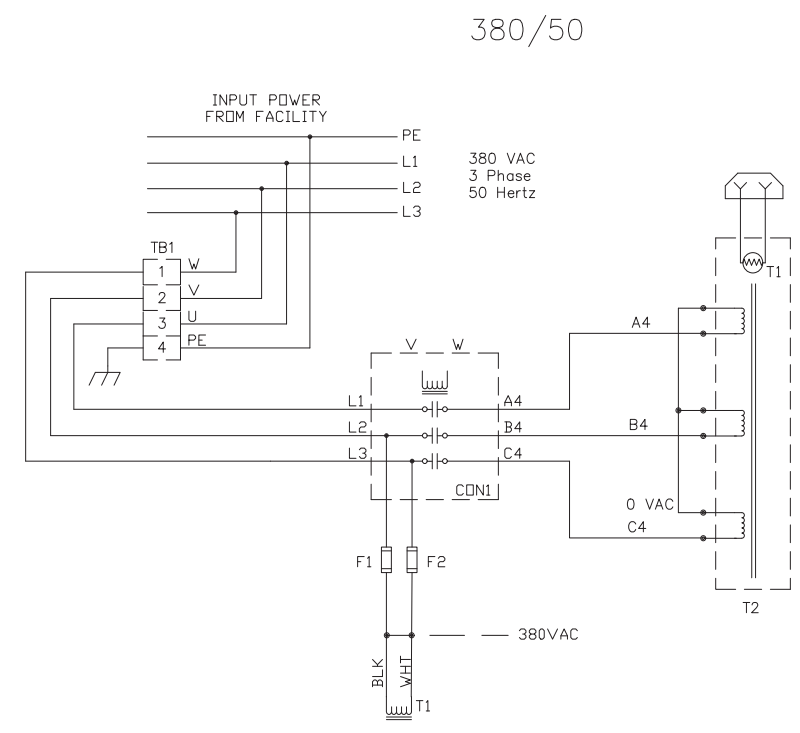
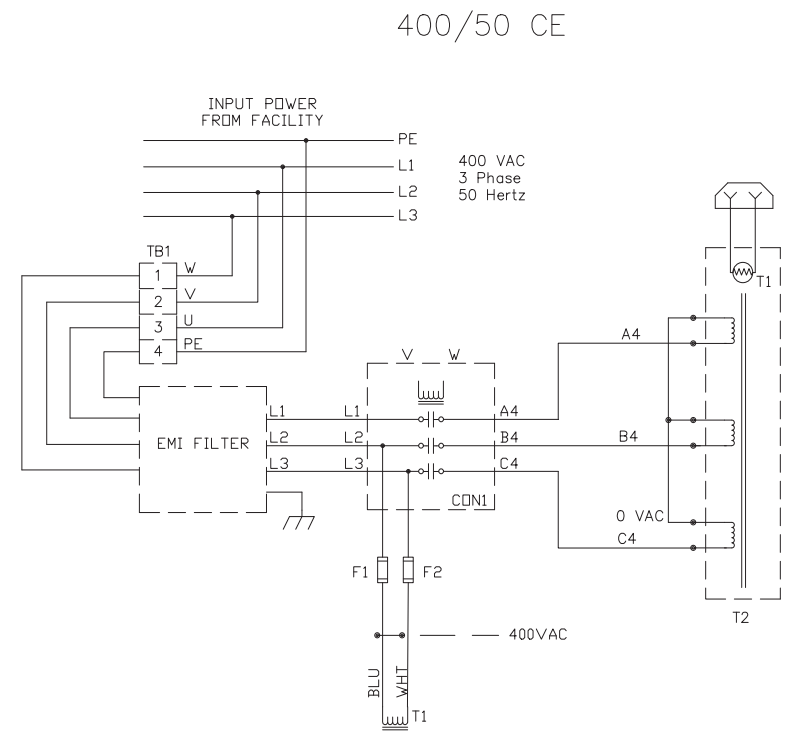
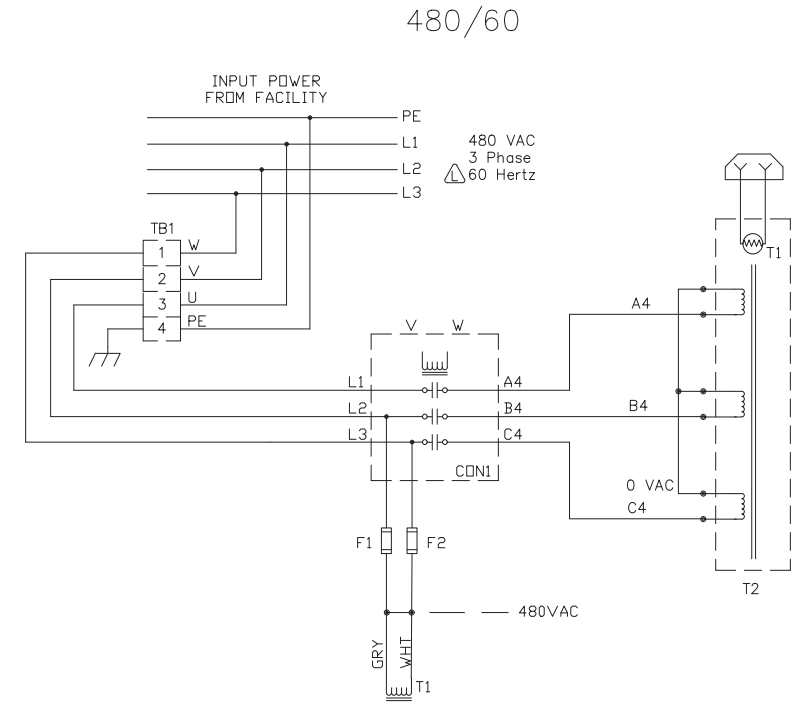
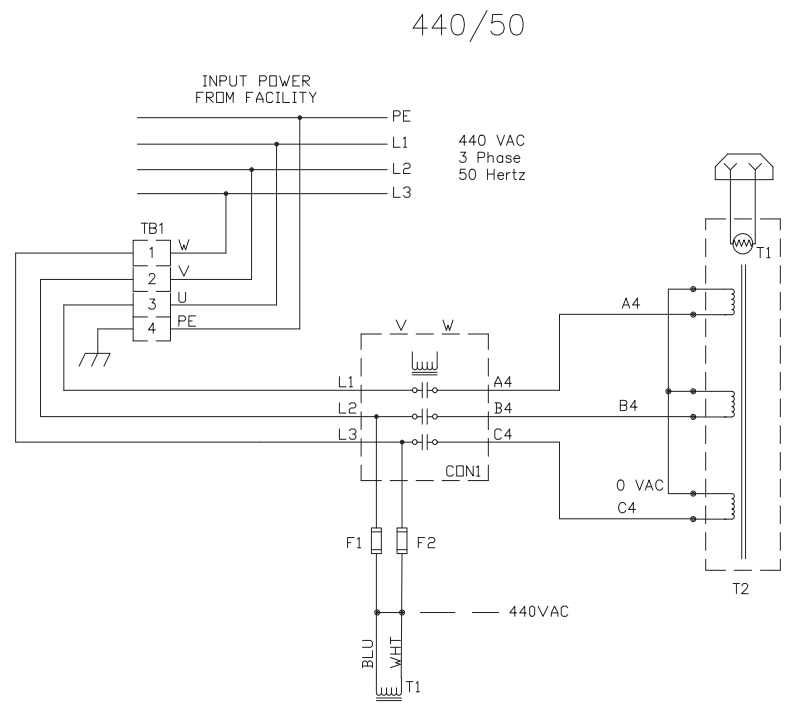

ELEC SCH: HPR800XD PWR SPLY W/AUTO
013381 L
SHEET 8 OF 24

4

3

2

1

600/60

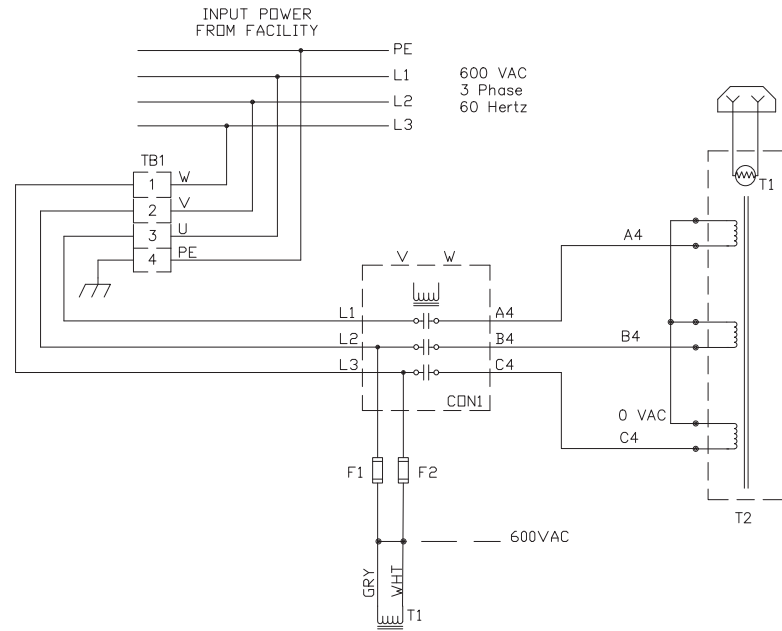

240/60

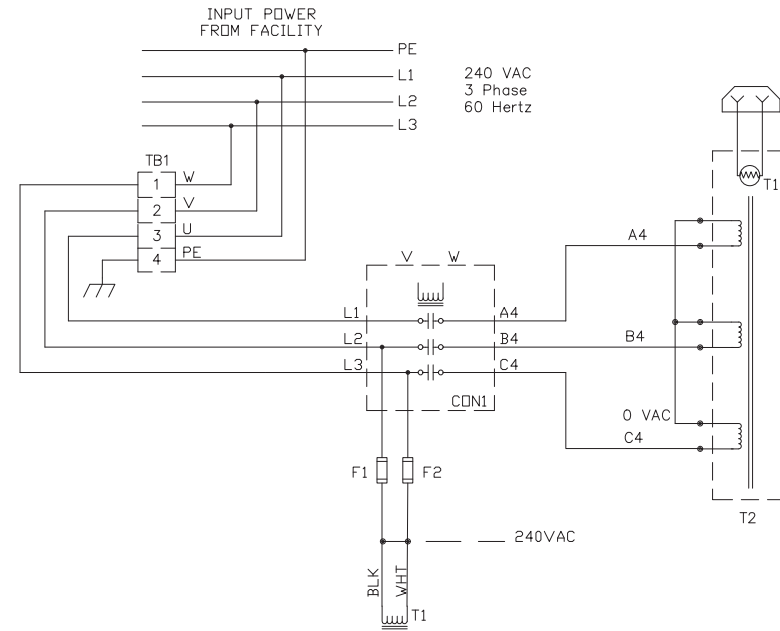

200/50-60

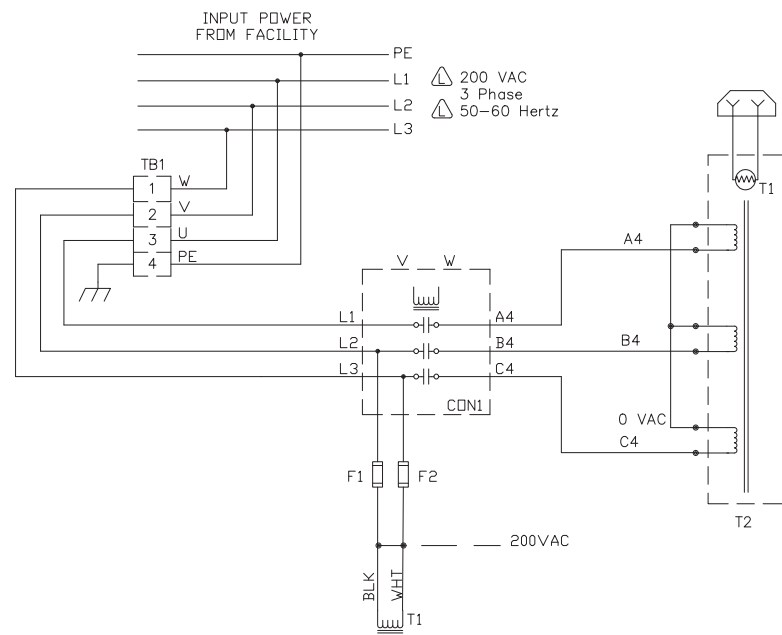

220/50-60

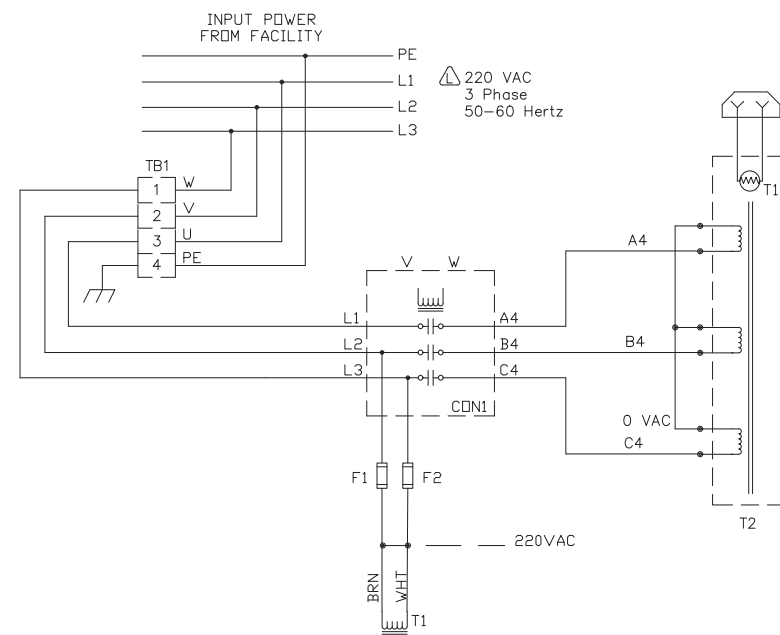

4

3

2

1

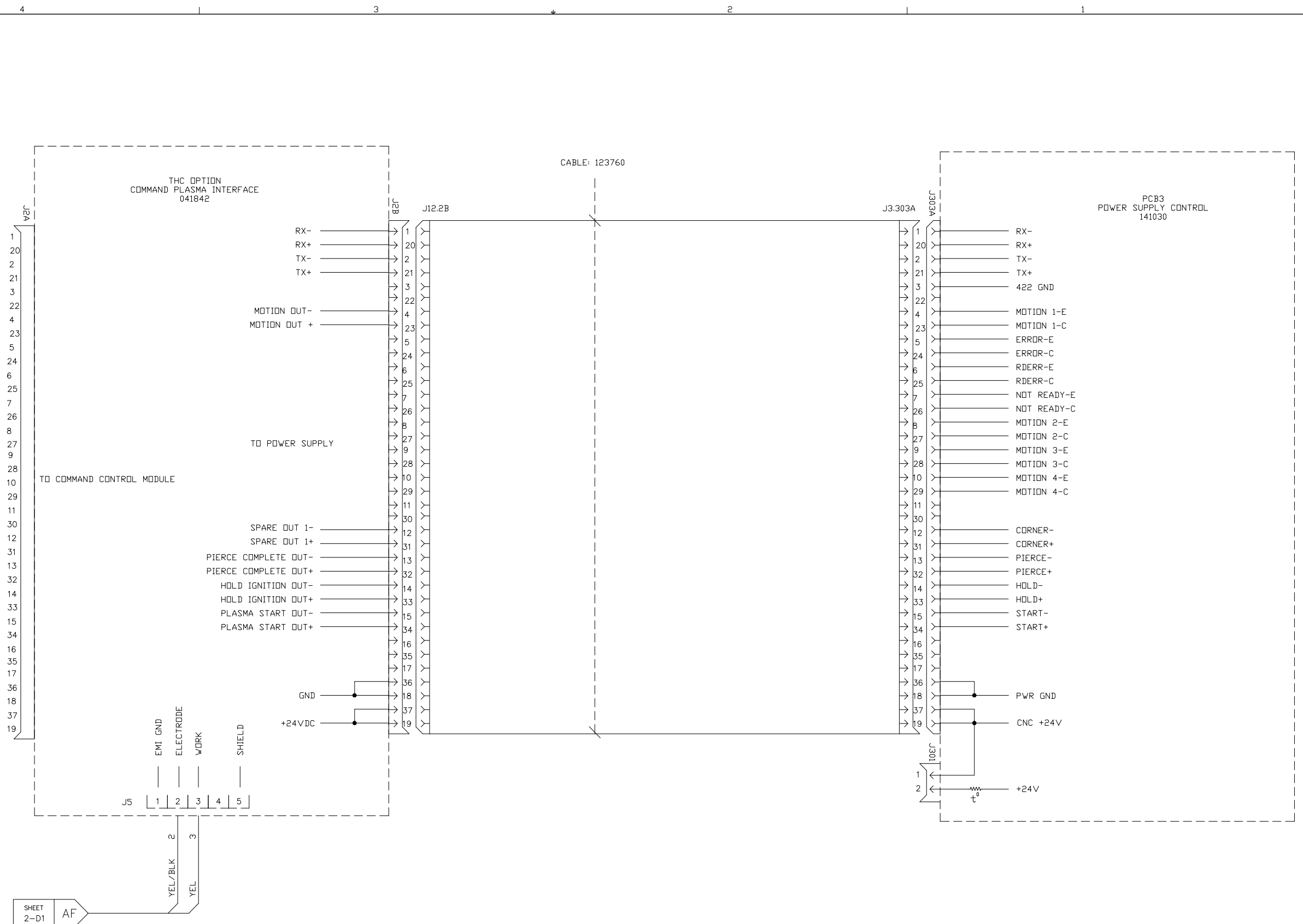

SHEET 2-D1 AF

PCB1
HPR AUTO GAS
SELECTION CONSOLE
POWER DISTRIBUTION
041897

GAS CONSOLE
DC POWER

D4 +5VDC
D2 SV16 ENABLED

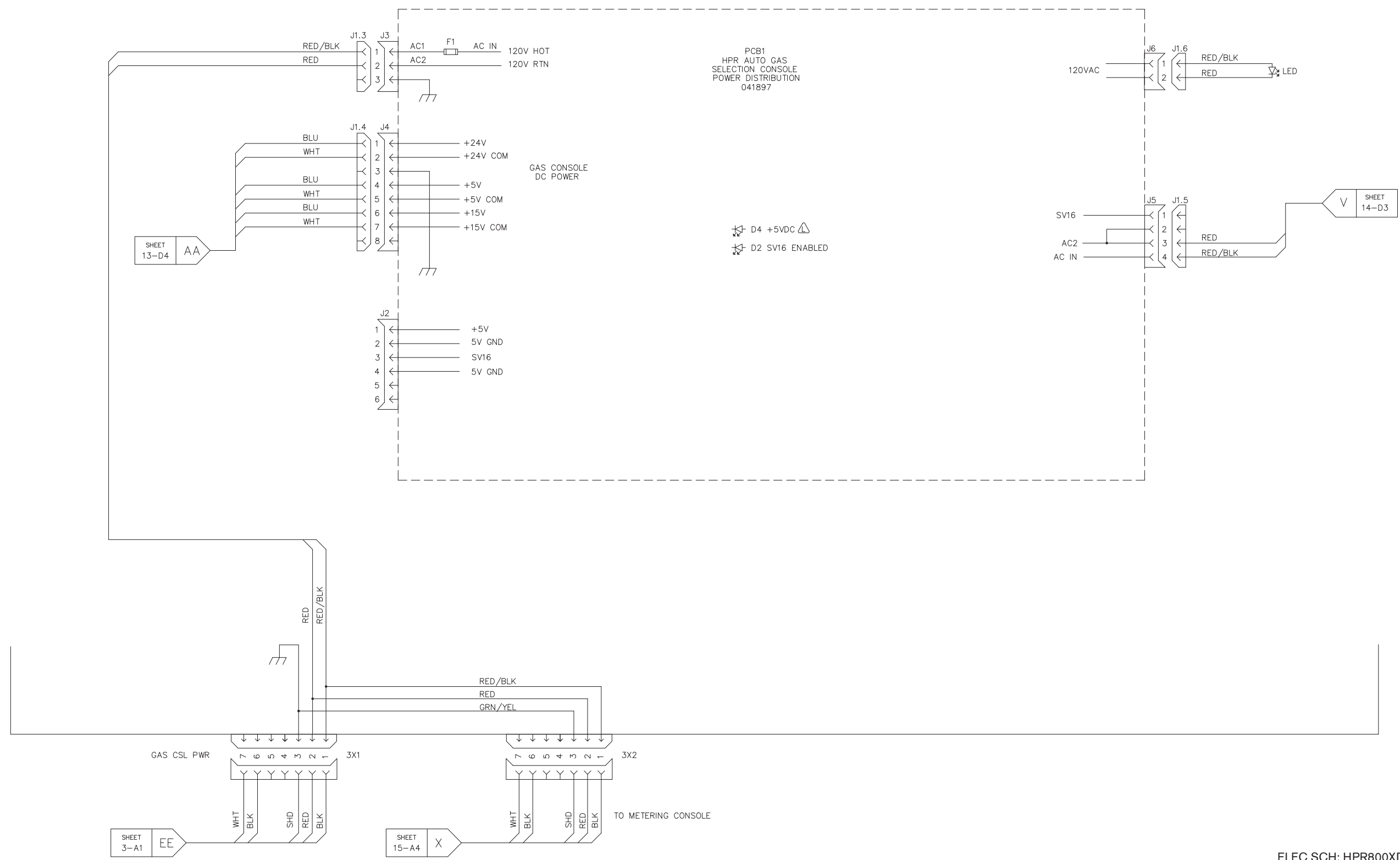

ELEC SCH: HPR800XD PWR SPLY W/AUTO
013381 L
SHEET 12 OF 24

SHEET 12-C4 AA

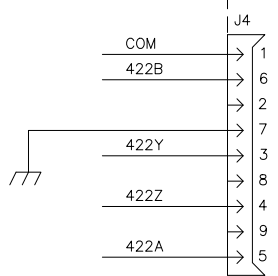
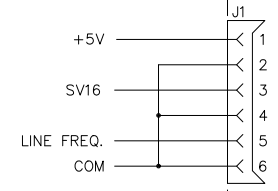
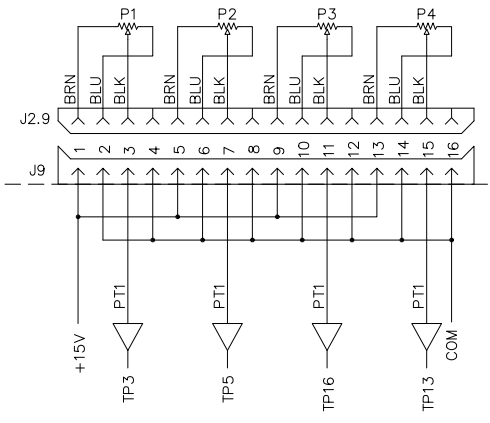
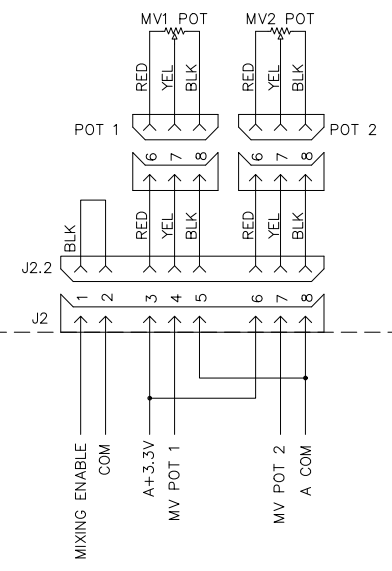
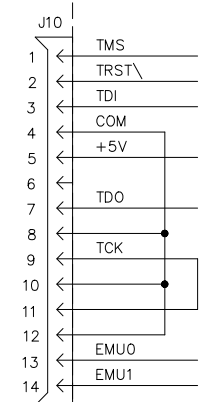
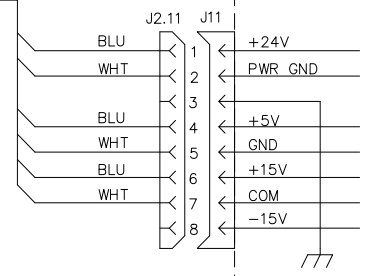

PCB2
HPR AUTO GAS
SELECTION CONSOLE
CONTROL
041828

POWER INDICATORS

- D45 +24V
- D40 +15V
- D18 +5V
- D17 +3.3V

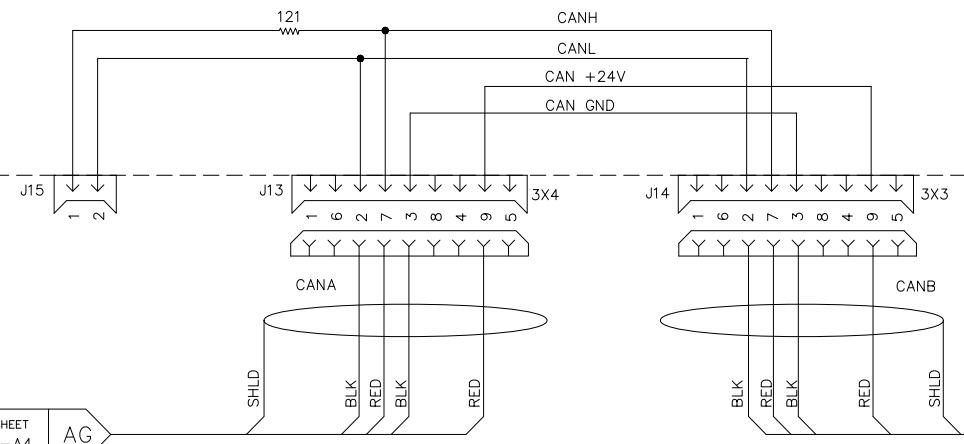

RS-422

TO METERING CONSOLE

SHEET 6-A4 AG

AB SHEET 16-A3

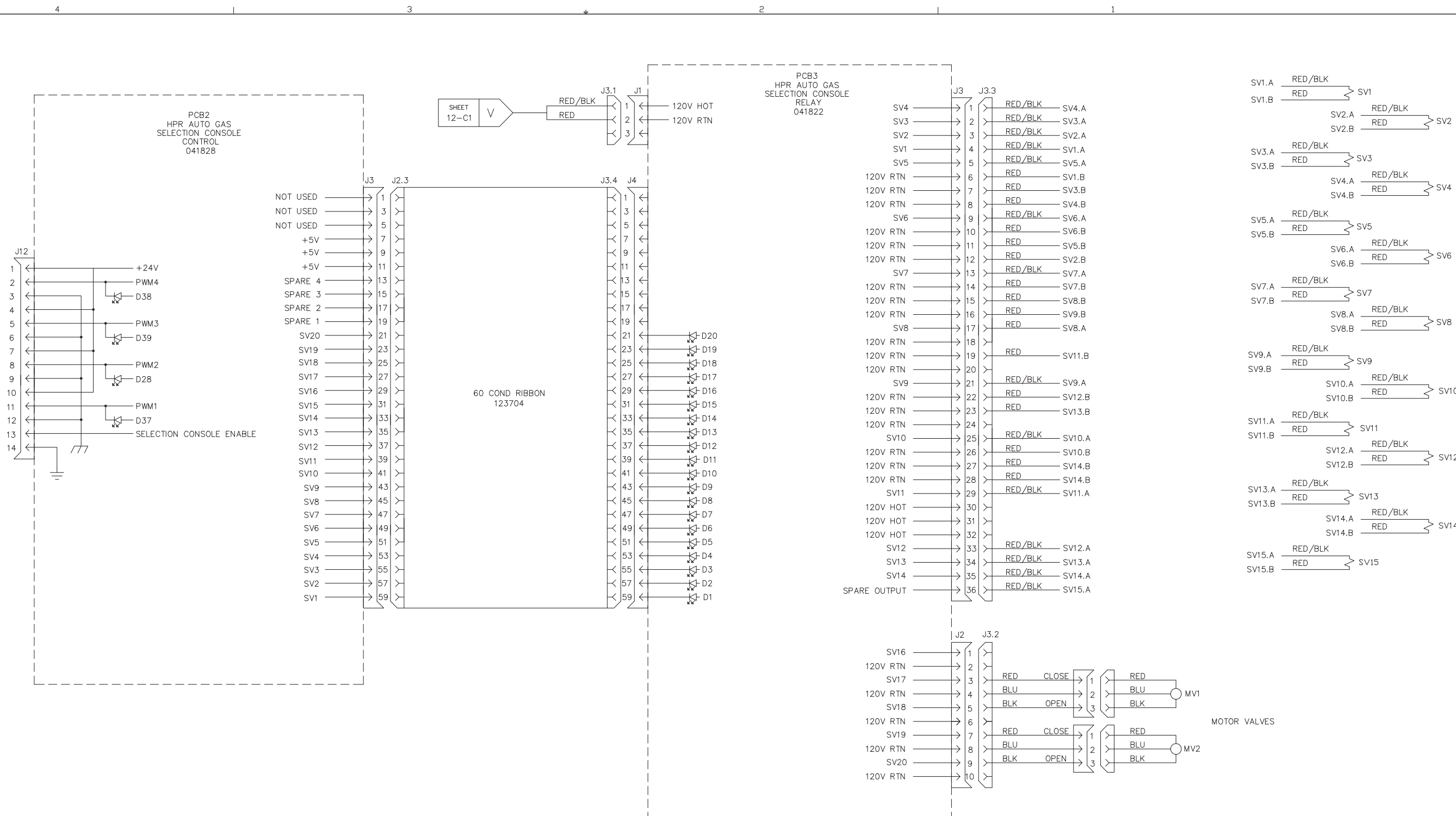

ELEC SCH: HPR800XD PWR SPLY W/AUTO
 013381 L
 SHEET 14 OF 24

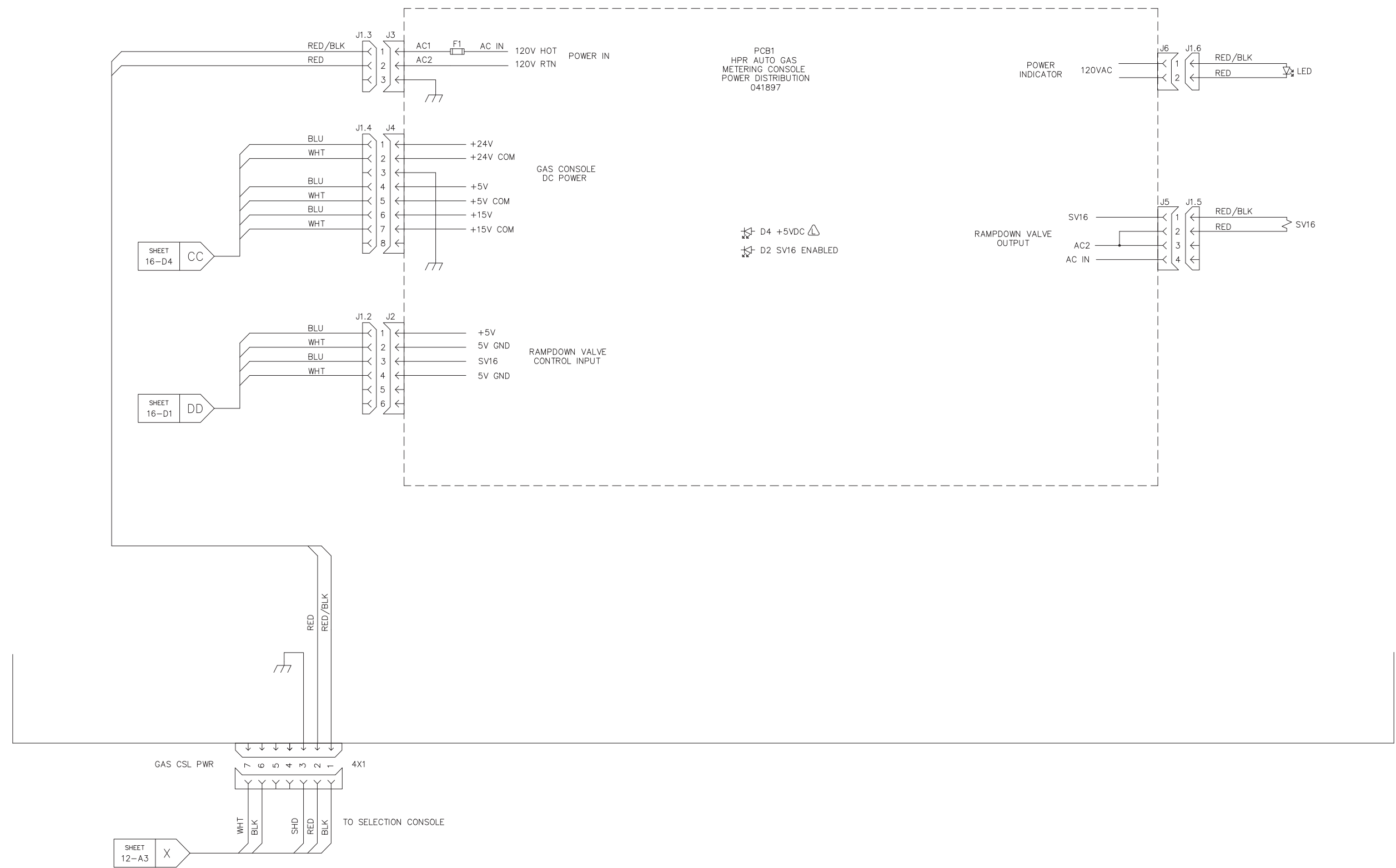

ELEC SCH: HPR800XD PWR SPLY W/AUTO
013381 L
SHEET 15 OF 24

SHEET 15-C4 CC

DD SHEET 15-C4

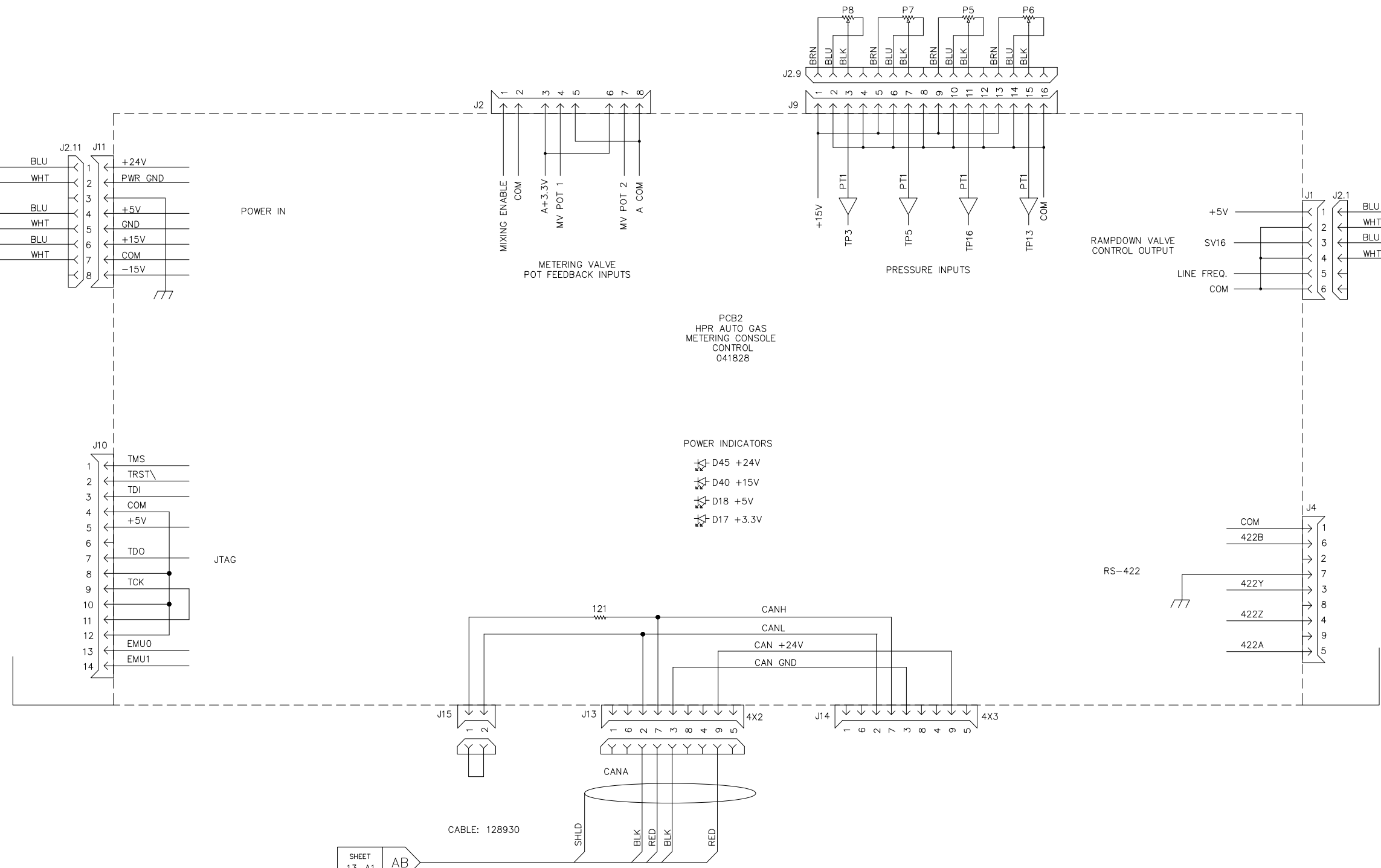

ELEC SCH: HPR800XD PWR SPLY W/AUTO
013381 L
SHEET 16 OF 24

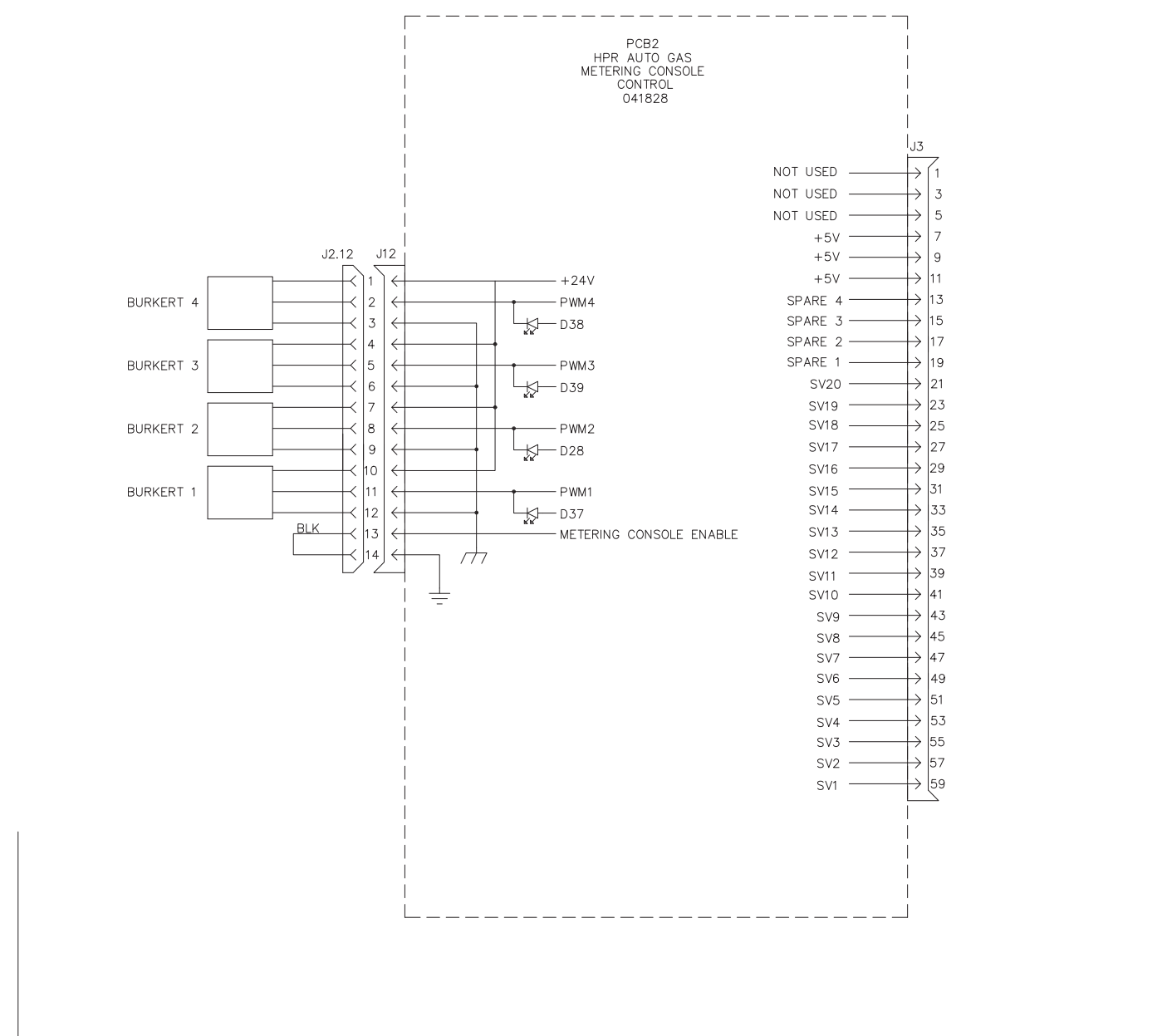

4

3

2

1

D

C

B

A

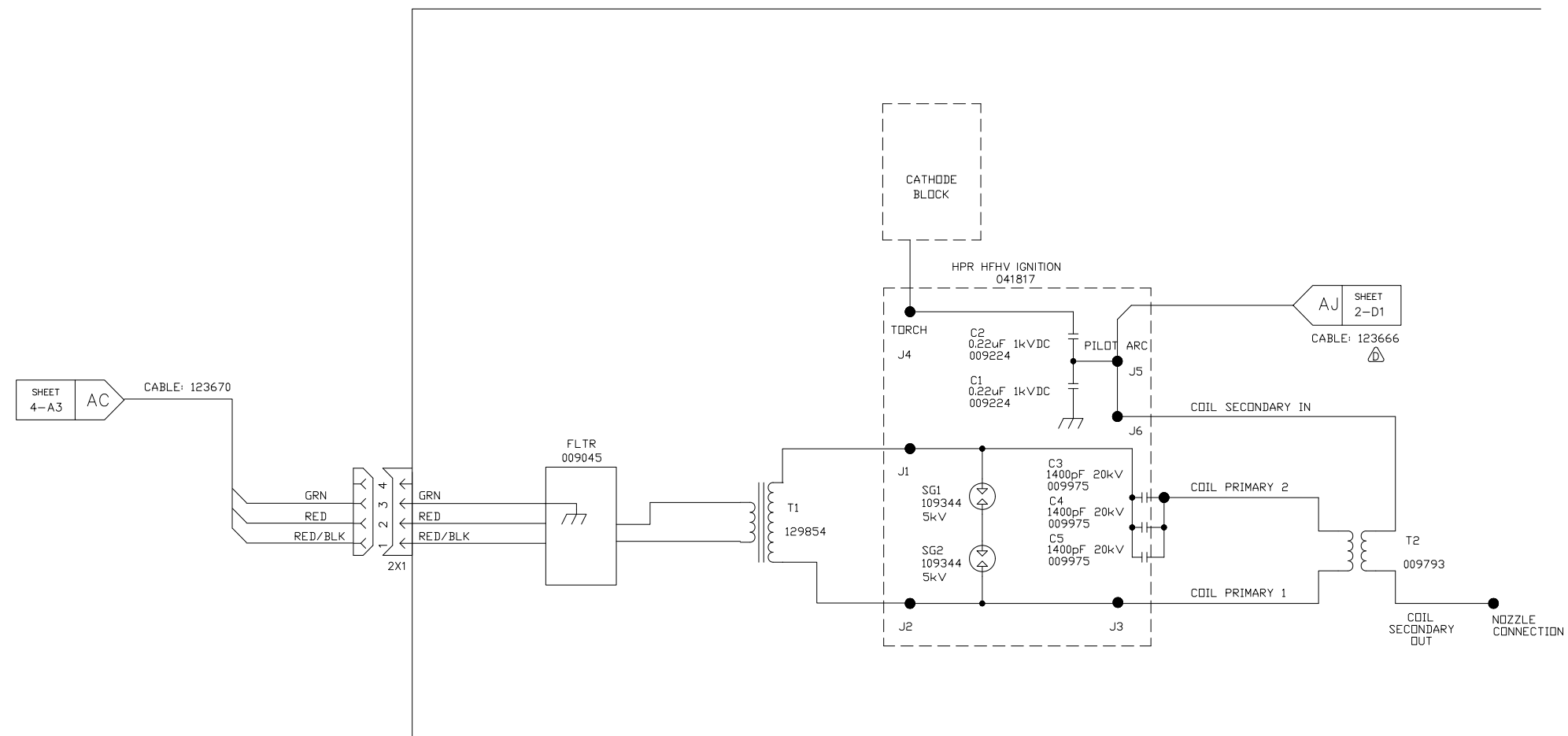

SHEET 4-A.3

CABLE: 123670

GRN
RED
RED/BLK

2X1

FLTR
009045

T1
129854

J1
SG1
109344
5kV
SG2
109344
5kV

C3
1400pF
20kV
009975
C4
1400pF
20kV
009975
C5
1400pF
20kV
009975

J2
J3

COIL PRIMARY 2
COIL PRIMARY 1

T2
009793

COIL SECONDARY IN
COIL SECONDARY OUT

NOZZLE CONNECTION

CATHODE BLOCK

HPR HFHV IGNITION
041817

TORCH
J4

C2
0.22uF
1kVDC
009224
C1
0.22uF
1kVDC
009224

PILOT
ARC
J5
J6

AJ
SHEET 2-D1
CABLE: 123666

ELEC SCHE: HPR800XD PWR SPLY W/AUTO
013381 L
SHEET 18 OF 24

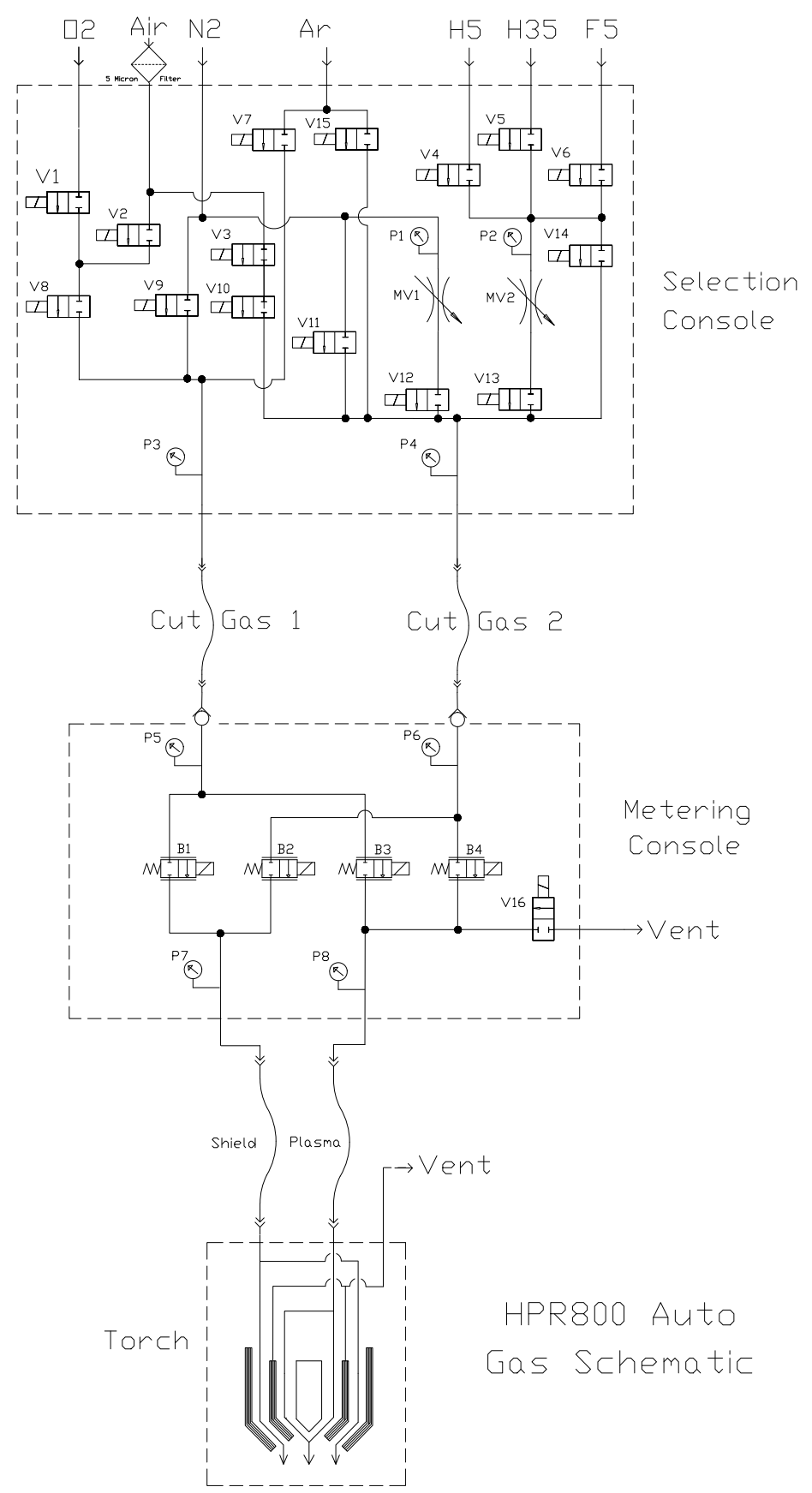

ELEC SCH: HPR800XD PWR SPLY W/AUTO
 013381 L
 SHEET 20 OF 24

Optional Multi-System Interface

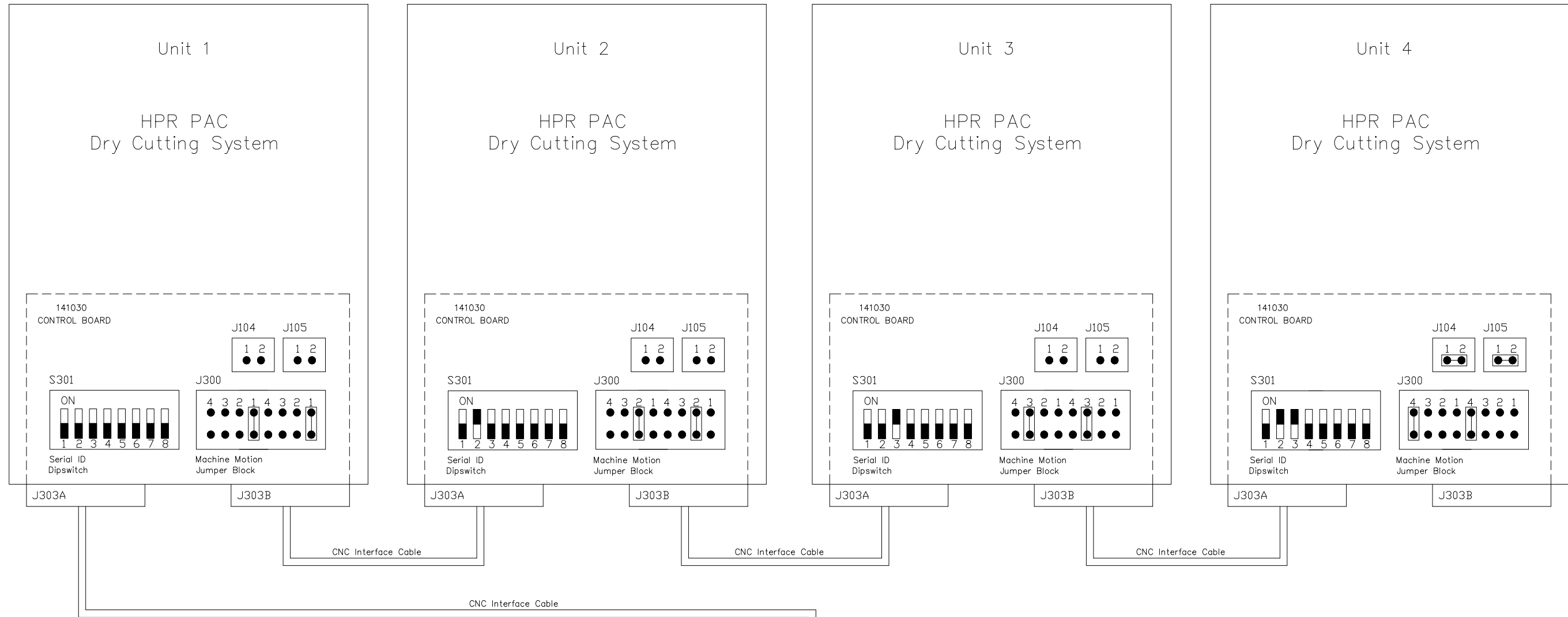

Notes:

- 1) For single system installations set Serial ID (S301), and Machine Motion (J300) as shown in Unit 1, jumpers J104 and J105 must be closed.
- 2) On multi-system installations refer to the illustration. Jumpers J104 and J105 are left open on all systems except for the very last system where they are in the closed position. Termination resistors (120-ohm) or termination jumpers must be installed/set at the CNC for each of the RS-422 RX and TX signal pairs.
- 3) If a Hypertherm Automation Controller is being used, and there are intermittent communication failures (PS Link Failure), try removing the jumpers on J104 and J105 on the control board, and the termination jumper (J6 or J8) on the serial isolation board in the controller. Only remove the termination jumper on the serial isolation board that is connected to the HPR power supply. See sheet 19 for more details.

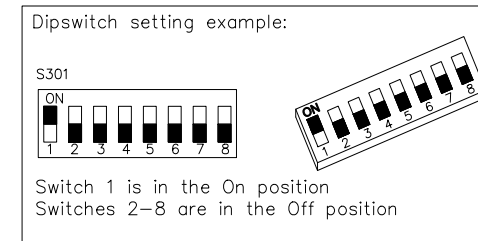
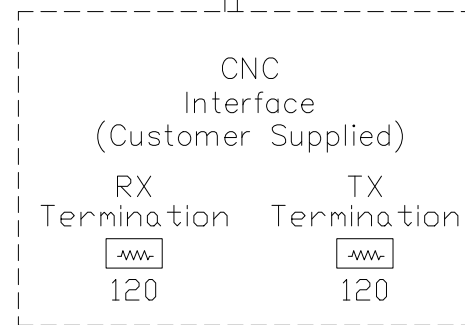

Optional Remote On/Off

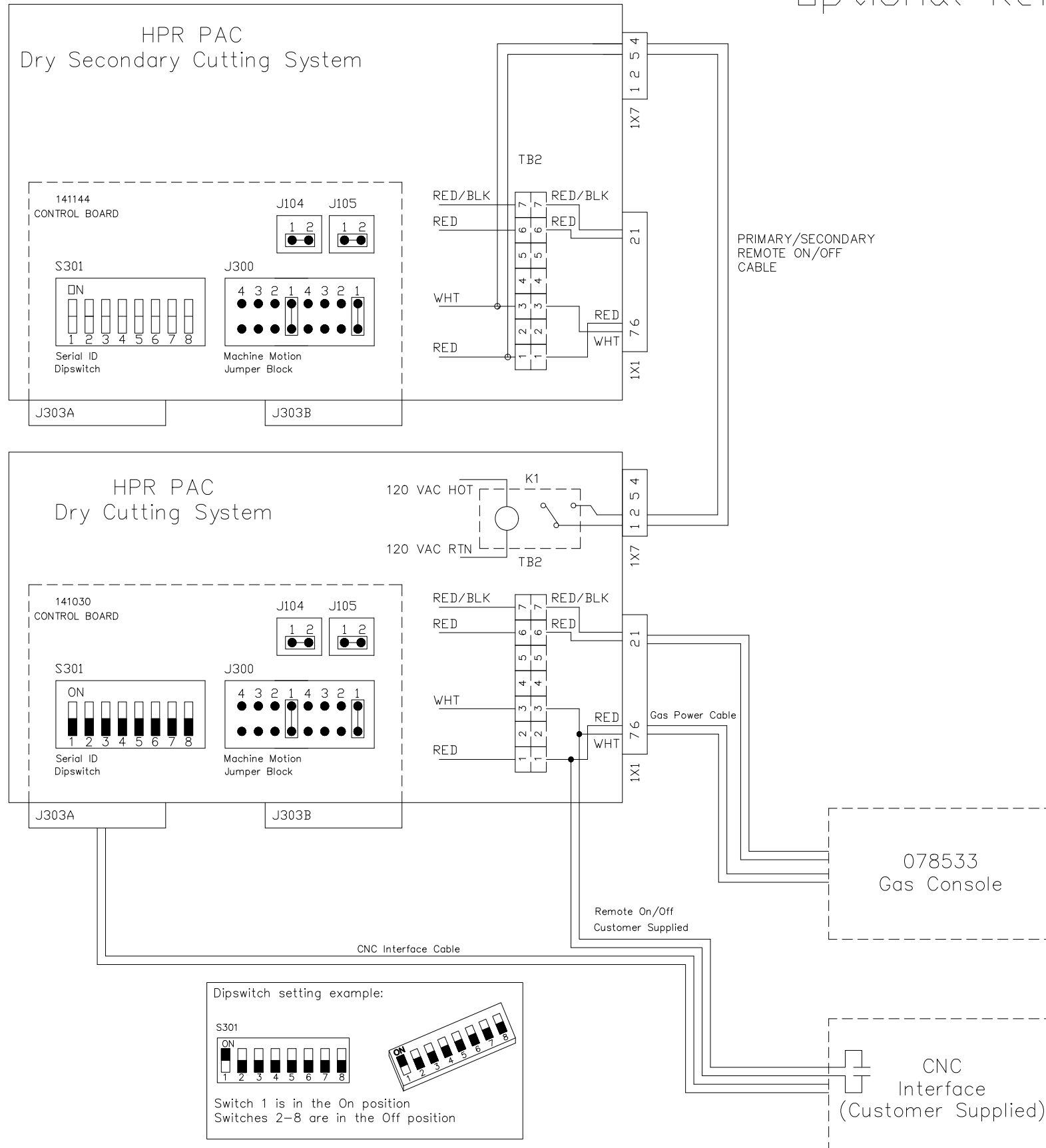

PRIMARY/SECONDARY
REMOTE ON/OFF
CABLE

Notes:

- 1) For single system installation set Serial ID (S301), Machine Motion (J300), J104 & J105 as shown.

Connect customer supplied remote on/off cable in parallel with the power supply terminals 1&3 of TB2.

Refer to page 3 of the wiring diagram
- 2) For a multi-system installation set up as described above, set jumpers as shown on the multi-system interface page
- 3) The CNC will need a dedicated I/O for each system using the Remote On/Off feature (contact should be rated for min. 24Vac, 0.5 Amp)

* If a Hypertherm Automation controller is being used, and there are intermittent communication failures (PS Link Failure), try removing the jumpers on J104 and J105 on the control board, and the termination jumper (J6 or J8) on the serial isolation board in the controller. Only remove the termination jumper on the serial isolation board that is connected to the HPR power supply. See figure below for details.

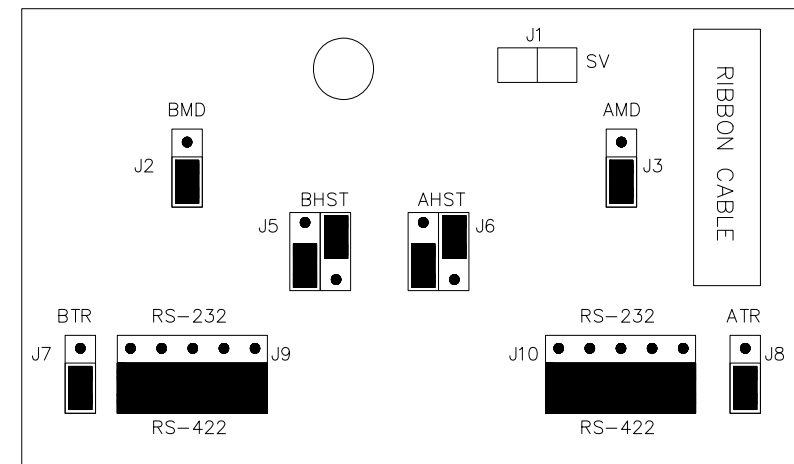

Serial isolation board in Hypertherm Automation controller

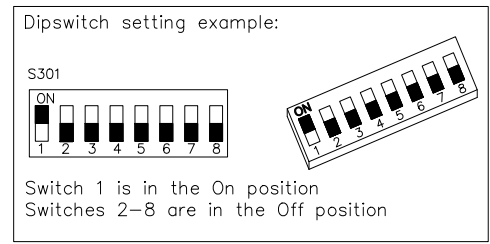

Optional Command THC Interface

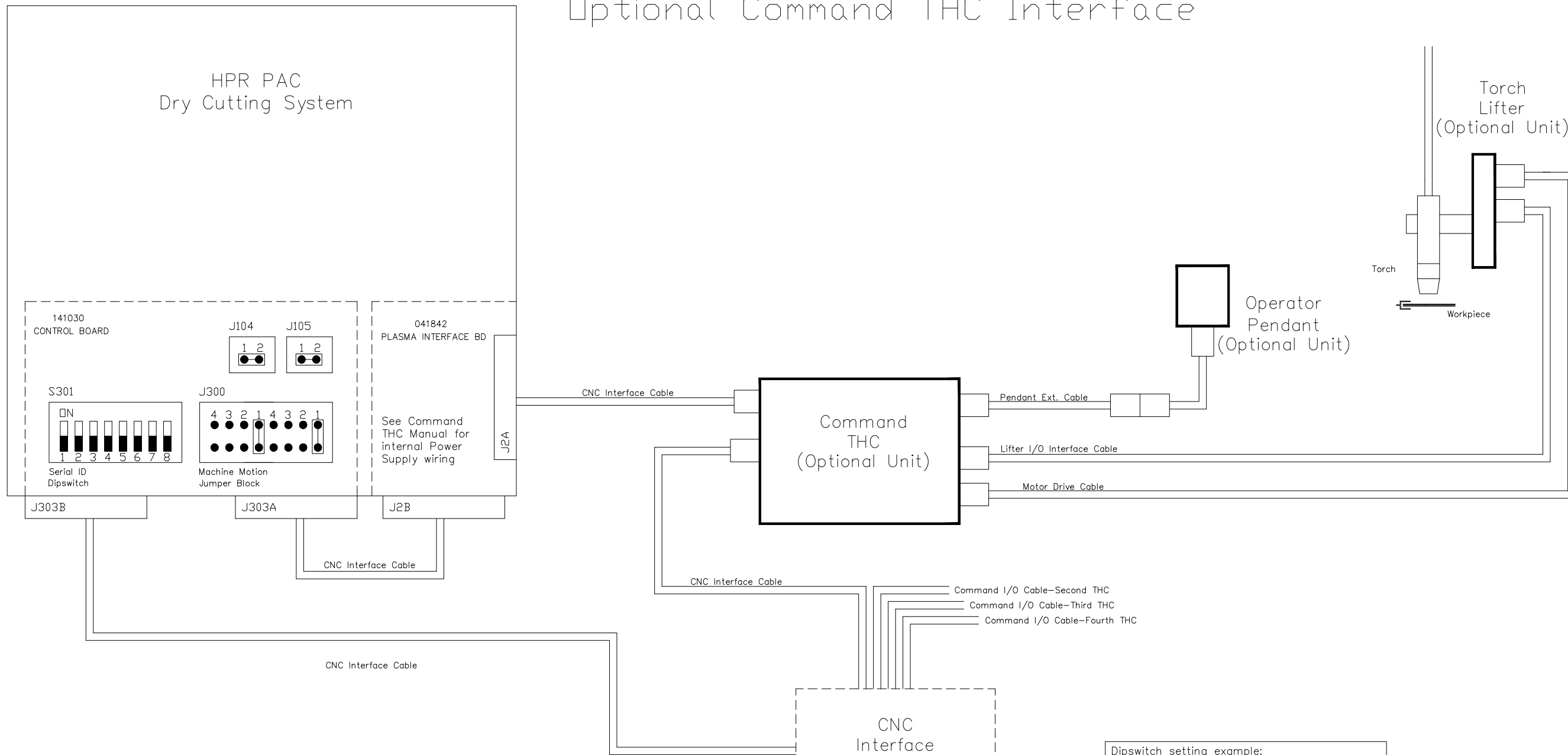

Notes:

- 1) For a single system installation set Serial ID (S301), Machine Motion (J300), J104 & J105 as shown above.
- 2) For a two system installation duplicate a second power supply and Command THC as illustrated for a single system, set Serial ID as shown for the second system.
- 3) For a three system installation set up as described above, set Serial ID as shown for the third system.
- 4) For a four system installation set up as described above, set Serial ID as shown for the fourth system.
- 5) All machine interface cables (Pwr. supply-CNC) used for serial communication between Pwr. supply-CNC will have a common connection node with the CNC.
- 6) The CNC will need a dedicated I/O port for each Command THC.
- 7) If a Hypertherm Automation controller is being used, and there are intermittent communication failures (PS Link Failure), try removing the jumpers on J104 and J105 on the control board, and the termination jumper (J6 or J8) on the serial isolation board in the controller. Only remove the termination jumper on the serial isolation board that is connected to the HPR power supply. See figure on Sheet 19 for details.

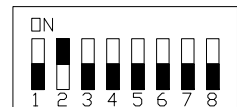

S301
Serial ID
Dipswitch
for second system

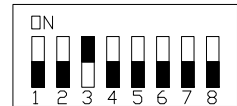

S301
Serial ID
Dipswitch
for third system

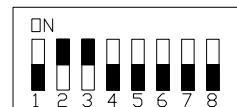

S301
Serial ID
Dipswitch
for fourth system

Dipswitch setting example:

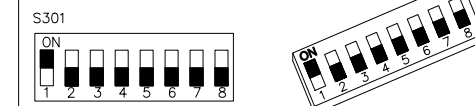

Switch 1 is in the On position
Switches 2-8 are in the Off position

Optional ArcGlide/EdgePro Multi-System Interface

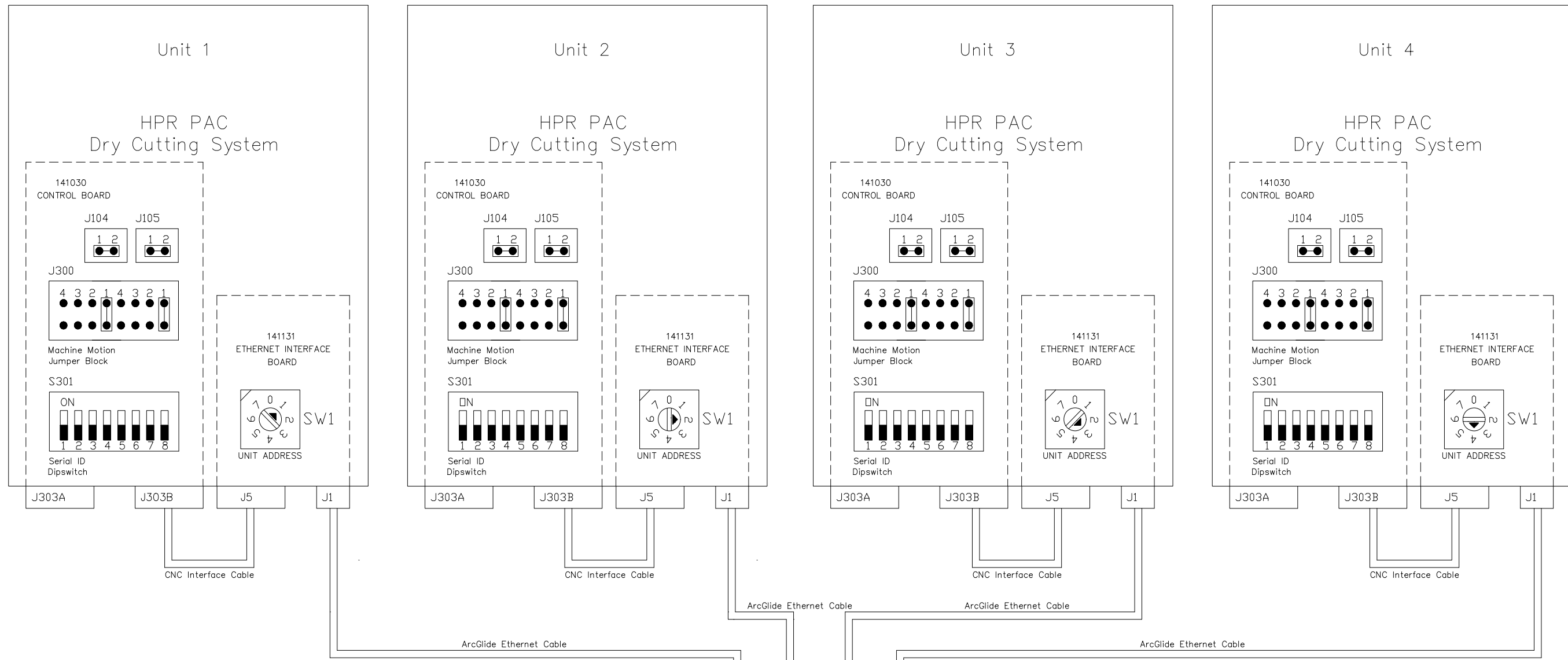

Notes:

- 1) For the 141030 control board, set Serial ID (S301), and Machine Motion (J300) as shown. Jumpers J104 and J105 should be installed. All 141030 DIPSWITCH and jumper settings are the same; serial IDs are determined by the 141131 board setting.
- 2) For a single system installation, set SW1 on the 141131 board as shown in Unit 1.
- 3) For a two system installation, set SW1 on the 141131 boards as shown in Units 1 through 2.
- 4) For a three system installation, set SW1 on the 141131 boards as shown in Units 1 through 3.
- 5) For a four system installation, set SW1 on the 141131 boards as shown in Units 1 through 4.

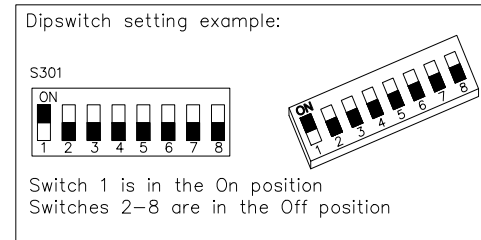

ArcGlide THC
and/or EdgePro Module(s)

HYPERTHERM TORCH COOLANT SAFETY DATA

In this section:

1 – Identification of the substance/mixture and of the company undertaking..... a-2

2 – Hazards identification a-2

3 – Composition/information on ingredients..... a-3

4 – First aid measures a-3

5 – Fire-fighting measures..... a-3

6 – Accidental release measures..... a-3

7 – Handling and storage a-4

8 – Exposure controls/personal protection a-4

9 – Physical and chemical properties a-4

10 – Stability and reactivity..... a-5

11 – Toxicological information a-5

12 – Ecological information..... a-5

13 – Disposal considerations..... a-6

14 – Transport information a-6

15 – Regulatory information..... a-6

16 – Other information a-7

Freezing Point of Propylene Glycol Solution a-8

Date	SAFETY DATA SHEET	Revision
6 Dec 2010	Torch Coolant 30% PG Mixture	2.01CLP

1 – Identification of the substance/mixture and of the company undertaking

Product identifier – Torch Coolant 30% PG Mixture

GHS Product Identifier – **Not applicable.**

Chemical Name – **Not applicable.**

Trade name – **Torch Coolant 30% PG Mixture**

CAS No. – **Not applicable.**

EINECS No. – **Not applicable.**

REACH Registration No. – **Not available.**

Relevant identified uses of the substance or mixture and uses advised against

Identified use(s) – **Industrial use only.**

Uses advised against – **Not available.**

Details of the supplier of the safety data sheet

Company Identification – **Hypertherm**

Telephone – **+1 (603) 643-5638 (USA), +31 (0) 165 596 907 (Europe)**

E-Mail (competent person) – **technical.service@Hypertherm.com**

Address – **P.O. Box 5010, Hanover, NH 03755 USA (USA),
Vaartveld 9, 4704 SE Roosendaal, Nederlands (Europe)**

Emergency telephone number – **(800) 255-3924 (USA), +1 (813) 248-0585 (International)**

Hypertherm®



2 – Hazards identification

EC Classification	NONE	GHS Classification Signal word(s)	NONE
NONE	NONE	NONE	NONE

According to Regulation (EC) No. 1272/2008 (CLP) – **NONE**

According to Directive 67/548/EEC & Directive 1999/45/EC – **NONE**

Preparation is not classified as hazardous in the sense of directive 1999/45/EC and 2006/121/EC.

Risk Phrases – NONE



Safety Phrases – NONE

Hazard statement(s) – NONE

Precautionary statement(s) – NONE

Date	SAFETY DATA SHEET	Revision
6 Dec 2010	Torch Coolant 30% PG Mixture	2.01CLP

3 – Composition/information on ingredients

HAZARDOUS INGREDIENT 1	% W/W	CAS No.	EC No.	EC Classification
Propylene Glycol	30-50	57-55-6	200-338-0	NONE
GHS Classification				
Not classified				NONE
HAZARDOUS INGREDIENT 2	% W/W	CAS No.	EC No.	EC Classification
Benzotriazole	<1.0	95-14-7	202-394-1	Xn, F
GHS Classification				
WARNING	 	Acute Tox. 4 (Oral, Dermal, Inhalation) Eye Irrit. 2, Aquatic Chronic 3		H302, 312, 319, 332, 412

For full text of R phrases see section 16. For full text of H/P phrases see section 16. Non-hazardous components are not listed.

4 – First aid measures

Inhalation	Unlikely to be hazardous by inhalation unless present as an aerosol. Remove patient from exposure.
Skin Contact	Wash skin with water.
Eye Contact	If substance has gotten into the eyes, immediately wash out with plenty of water for several minutes.
Ingestion	Laxative. Do not induce vomiting. If swallowed, seek medical advice immediately and show this container or label.
Further Medical Treatment	Unlikely to be required but if necessary treat symptomatically.

5 – Fire-fighting measures

Combustible but not readily ignited.

Extinguishing media	Extinguish preferably with dry chemical, foam or water spray
Unsuitable Extinguishing Media	None known
Fire Fighting Protective Equipment	A self contained breathing apparatus and suitable protective clothing should be worn in fire conditions

6 – Accidental release measures

Personal Precautions	Put on protective clothing
Environmental Exposure Controls	Absorb spillages onto sand, earth or any suitable adsorbent material
Other	None

Date	SAFETY DATA SHEET	Revision
6 Dec 2010	Torch Coolant 30% PG Mixture	2.01CLP

7 – Handling and storage

Handling	Unlikely to cause harmful effects under normal conditions of handling and use.
Storage	Keep container tightly closed and dry. Keep away from heat. Keep out of the reach of children. Keep away from oxidizing agents.
Storage Temperature:	Ambient.
Storage Life:	Stable at ambient temperatures.
Specific Use:	Industrial use only.

8 – Exposure controls/personal protection

	Respirators	Normally no personal respiratory protection is necessary. Wear suitable respiratory protective equipment if exposure to levels above the occupational exposure limit is likely. A suitable dust mask or dust respirator with filter type A/P may be appropriate.
	Eye Protection	Safety spectacles.
	Gloves	Wearing of chemical protective gloves is not necessary.
	Body protection	None.
	Engineering Controls	Ensure adequate ventilation to remove vapors, fumes, dust etc.
	Other	None.

OCCUPATIONAL EXPOSURE LIMITS

SUBSTANCE	CAS No.	LTEL (8 hr TWA ppm)	LTEL (8 hr TWA mg/m ³)	STEL (ppm)	STEL (mg/m ³)	Note:
Propylene Glycol	57-55-6	NE	10*	NE	NE	AIHA WEEL in the USA
Benzotriazole	95-14-7	NE	NE	NE	NE	None

9 – Physical and chemical properties

Information on basic physical and chemical properties

Appearance – Liquid	Vapor Pressure (mm Hg) – Not available
Color – Pinkish – Reddish	Vapor Density (Air=1) – Not available
Odor – Slight	Density (g/ml) – 1.0 ± 0.1 g/ml
Odor Threshold (ppm) – Not available	Solubility (Water) – Soluble
pH (Value) – 5.5-7.0 (Concentrated)	Solubility (Other) – Not established
Melting Point (°C) / Freezing Point (°C) – < -0°C / (< 32°F)	Partition Coefficient (n-Octanol/water) – Not available
Boiling point/boiling range (°C): >100°C (>212°F)	Auto Ignition Temperature (°C) – Not available
Flash Point (°C) – >95°C (>203°F)	Decomposition Temperature (°C) – Not available
Evaporation rate – Not available	Viscosity (mPa.s) – Not available
Flammability (solid, gas) – Non-flammable	Explosive properties – Not explosive
Explosive limit ranges – Not available	Oxidizing properties – Not oxidizing
Other information – None	

Date	SAFETY DATA SHEET	Revision
6 Dec 2010	Torch Coolant 30% PG Mixture	2.01CLP

10 – Stability and reactivity

Reactivity	None
Chemical stability	Stable under normal conditions
Possibility of hazardous reactions	None
Conditions to avoid	None anticipated
Incompatible materials	Keep away from oxidizing agents
Hazardous Decomposition Product(s)	Carbon monoxide, Carbon dioxide, Nitrogen oxides

11 – Toxicological information

11.1.1 – Substances

Acute toxicity	
Ingestion	Low oral toxicity, but ingestion may cause irritation of the gastrointestinal tract
Inhalation	Unlikely to be hazardous by inhalation
Skin Contact	Mild irritant to rabbit skin
Eye Contact	Mild irritant to the eye
Hazard label(s)	None
Serious eye damage/irritation	Mild irritant to the eye
Respiratory or skin sensitization	Mild irritant to rabbit skin
Mutagenicity	Not known
Carcinogenicity	IARC, NTP, OSHA, ACGIH do not list this product or any components thereof as known or suspected carcinogen
Reproductive toxicity	Not known
STOT-single exposure	Not known
STOT-repeated exposure	Not known
Aspiration hazard	Not known

12 – Ecological information

Toxicity	Do not let this chemical/product enter the environment.
Persistence and degradability	Biodegradable
Bioaccumulative potential	None anticipated
Mobility in soil	The product is predicted to have moderate mobility in soil
Results of PBT and vPvB assessment	None assigned
Other adverse effects	None anticipated

Date	SAFETY DATA SHEET	Revision
6 Dec 2010	Torch Coolant 30% PG Mixture	2.01CLP

13 – Disposal considerations

Waste treatment methods – Disposal should be in accordance with local, state or national legislation. No special measures are required. No specific waste water pretreatment required.

Additional Information – None

14 – Transport information

Not classified as dangerous for transport.

Transport in bulk according to Annex II of MARPOL73/78 and the IBC Code.

15 – Regulatory information

USA

TSCA (Toxic Substance Control Act) – **Listed.**

SARA 302 – Extremely Hazardous Substances – **Not applicable.**

SARA 313 – Toxic Chemicals – **Not applicable.**

SARA 311/312 – Hazard Categories – **None.**

CERCLA (Comprehensive Environmental Response Compensation and Liability Act) – **Not applicable.**

CWA (Clean Water Act) – CWA 307 – Priority Pollutants – **None.**

CAA (Clean Air Act 1990) CAA 112 – Hazardous Air Pollutants (HAP) – **None.**

Proposition 65 (California) – **Not applicable.**

State Right to Know Lists – **CAS No. 95-14-7 Listed in MA, NJ, PA.**

Canada

WHMIS Classification (Canada) – **Not classified.**

CANADA INGREDIENT DISCLOSURE LIST – **Not applicable.**

Canada (DSL/NDSL) – **Listed.**

EU

EINECS (Europe) – **Listed.**

Wassergefährdungsklasse (Germany) – **None.**

Date	SAFETY DATA SHEET	Revision
6 Dec 2010	Torch Coolant 30% PG Mixture	2.01CLP

16 – Other information

The following sections contain revisions or new statements: 1–16.

Legend

LTEL	Long Term Exposure Limit
STEL	Short Term Exposure Limit
STOT	Specific Target Organ Toxicity
DNEL	Derived No Effect Level
PNEL	Predicted No Effect Concentration

References:

<p>Risk Phrases and Safety Phrases None. Preparation is not classified as hazardous in the sense of directive 1999/45/EC and 2006/121/EC.</p>
<p>Hazard statement(s) and Precautionary statement(s). None. Preparation is not classified as hazardous in the sense of directive 1999/45/EC and 2006/121/EC.</p>
<p>Training advice – None.</p>
<p>Additional Information USA – NFPA (National Fire Protection Association) – NFPA Rating: Flammability – 1, Health – 0, Instability/Reactivity – 0.</p> <p>Information contained in this publication or as otherwise supplied to Users is believed to be accurate and is given in good faith, but it is for the Users to satisfy themselves of the suitability of the product for their own particular purpose. Hypertherm gives no warranty as to the fitness of the product for any particular purpose and any implied warranty or condition (statutory or otherwise) is excluded except to the extent that exclusion is prevented by law. Hypertherm accepts no liability for loss or damage (other than that arising from death or personal injury caused by defective product, if proved), resulting from reliance on this information. Freedom under Patents, Copyright and Designs cannot be assumed.</p> <p>Note: Original safety data sheet authored in English</p>

Date	SAFETY DATA SHEET	Revision
6 Dec 2010	Torch Coolant 30% PG Mixture	2.01CLP

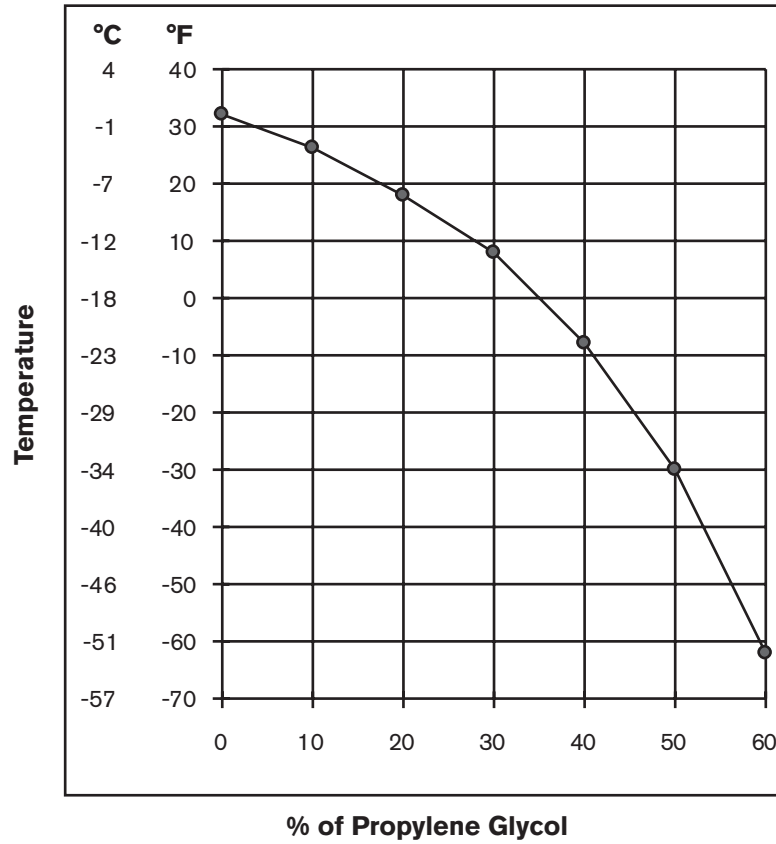

Freezing Point of Propylene Glycol Solution

CNC INTERFACE PROTOCOL

In this section

Interface hardware	b-2
Signal list.....	b-2
Signals	b-2
Hardware.....	b-3
Multi-drop wiring.....	b-4
Multi-drop addressing	b-5
Serial commands	b-5
Format	b-5
Framing	b-5
Commands.....	b-5
Command table (1 of 14)	b-6
Error responses	b-20
Calculating checksums.....	b-20
Error codes.....	b-21
Status codes.....	b-25
Gas type codes.....	b-25
CNC requirements	b-26
Auto gas console.....	b-26
Serial interface guidelines.....	b-27
Checksum	b-27
Message retries	b-27
Cable shielding	b-27

Interface hardware

- The interface will use a combination of discrete signals (5 inputs, 3 outputs, and 24 VDC active low) and an addressable RS422 interface.
- The hardware will provide 4 unique addresses, which allows 4 systems to be connected to one serial port on the CNC. The addressing mechanism will be inside the power supply, on a PC board (Note: A total of 32 I/O (20 Inputs, 12 Outputs) points will be required for 4 systems).
- The RS422 hardware will have tri-stateable transmitter to disconnect itself from the line when not communicating.
- Mounting holes for footprint of CommandTHC plasma interface board.
- Must have an interface compatible with the CommandTHC/HD4070.

Signal list

Signals

Signal name	Type	Description
Plasma Start	Input	When active, the plasma system will fire an arc.
Machine Motion 1	Output	Indicates the arc has transferred to the plate. This signal is selected using jumper on power supply control board. Only 1 motion signal is needed per system. The remaining motion signals can be used to wire multiple systems in a daisy chain configuration.
Machine Motion 2	Output	Indicates the arc has transferred to the plate. This signal is selected using jumper on power supply control board. Only 1 motion signal is needed per system. The remaining motion signals can be used to wire multiple systems in a daisy chain configuration.
Machine Motion 3	Output	Indicates the arc has transferred to the plate. This signal is selected using jumper on power supply control board. Only 1 motion signal is needed per system. The remaining motion signals can be used to wire multiple systems in a daisy chain configuration.
Machine Motion 4	Output	Indicates the arc has transferred to the plate. This signal is selected using jumper on power supply control board. Only 1 motion signal is needed per system. The remaining motion signals can be used to wire multiple systems in a daisy chain configuration.
Hold Ignition	Input	When active, the system will stay in preflow and delay torch ignition. The signal should be applied at the same time the start signal is applied.
System Error	Output	Indicates that an error has occurred in the plasma system. Use the serial interface to query for the specific error code number.

Signal list (continued)

Signal name	Type	Description
Pierce Complete	Input	When active, the system will use shield preflow gases during piercing. When the signal is removed, the system will switch to shield cutflow gases. The signal should be applied at the same time the start signal is applied.
Corner Current	Input	When active, the system will switch to user specified corner current.
Remote Power	Input	Used to turn the power on or off
Not Ready for Start	Output	When on, this signal indicates that the plasma system is not ready for a plasma start signal. This could be because the system is purging or in test gas mode.
Ramp-down Error	Output	Indicates the arc did not ramp-down properly. Consumable life is shortened.
TX+	Serial	Transmitting from the system Connect to CNC RX+
TX-	Serial	Transmitting from the system Connect to CNC RX-
RX+	Serial	Receiving by the system Connect to CNC TX+
RX-	Serial	Receiving by the system Connect to CNC TX-

Hardware

Inputs – active low, dry contact, opto-isolated

Inactive: 24 V or open circuit, 0 mA

Active: 0 V or closed contact (0 ohm min, 6.5 mA; 200K ohm max, 0.1 mA)

Outputs – active low, open collector, opto-isolated

Inactive: Up to 40 V open circuit/open collector, 0 mA

Recommended 24 V pull-up into high impedance load

Active: 0.3 V max output into high impedance load, sinking capacitor up to 5 mA

Or 2k ohm minimum load resistance

Serial – RS422 serial communications

Multi-drop wiring

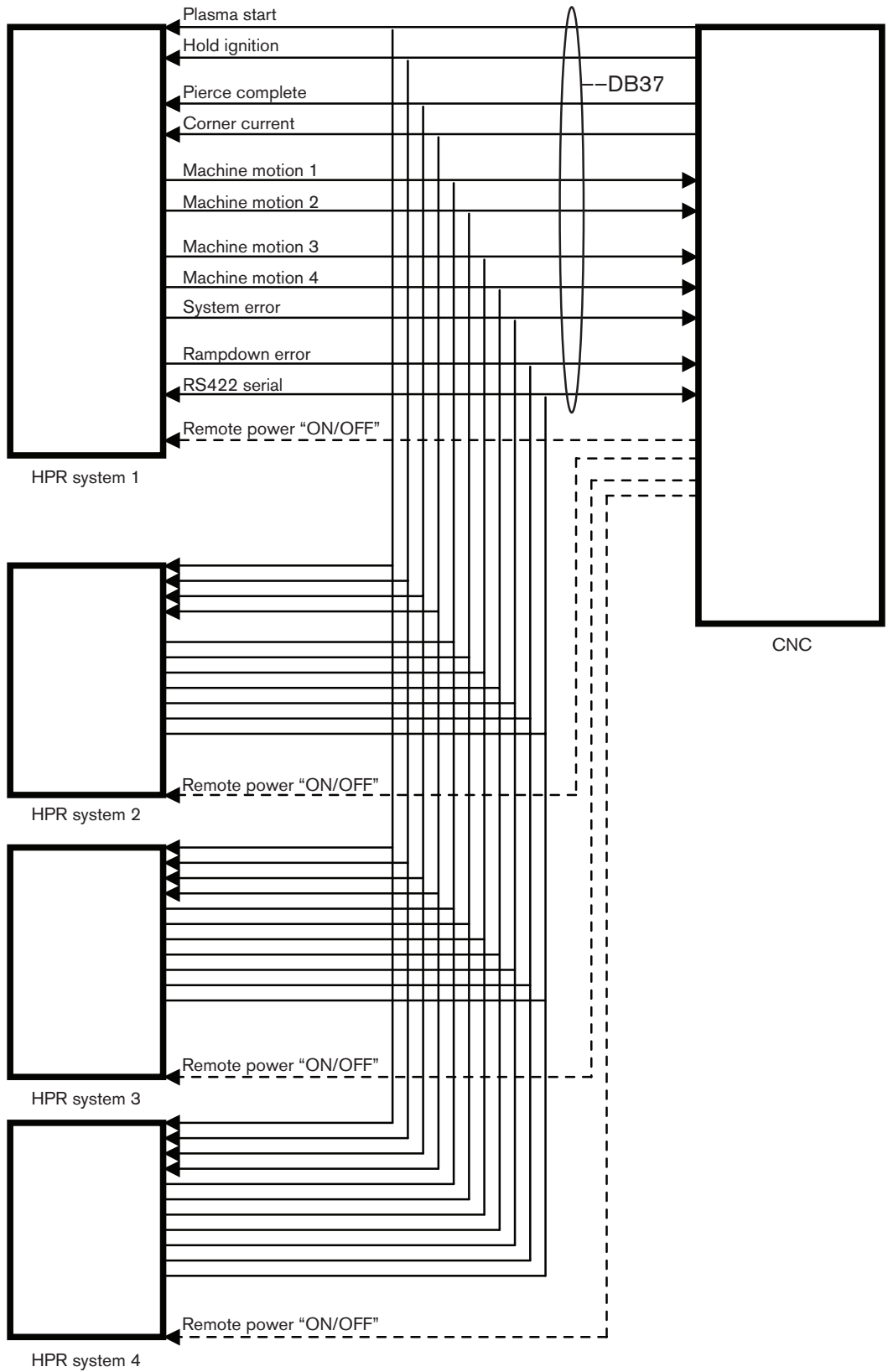

Multi-drop addressing

The power supply control has DIP switches to set the power supply ID. DIP switches 2, 3, 4 are used to set the ID.

2	3	4	ID
Off	Off	Off	0
On	Off	Off	1
Off	On	Off	2
On	On	Off	3
Off	Off	On	Reserved
On	Off	On	Reserved
Off	On	On	Reserved
On	On	On	Reserved

Systems with ID 0 power-up with the serial interface enabled. Systems with any other ID power-up with the serial interface disabled.

To implement the multi-drop interface, the CNC must send the SLEEP command (086) which will put all systems on the line into sleep mode. The WAKE command (085) with specific system ID will wake the system that the CNC wants to communicate with. Any command can now be sent to that power supply, while all other systems will ignore the communications. When the CNC is finished communicating with that power supply the SLEEP command must be sent, then the WAKE command is used to communicate with the next system.

Serial commands

Format

- ASCII-based protocol
- Baud 19200
- 8 Data bits
- 1 Stop bit
- No parity
- No flow control

Framing

- > = Start of message
- 3 byte command ID
- Data
- 2 byte checksum
- < = End of message

Sample: >0011C2<

Commands

Responses will echo the ID of the command, unless there is an error in the command.

Command table (1 of 14)

ID	Command	System	Description
000	HELLO	Manual gas system Auto gas system	Establish communications with the plasma system. Use this command to determine if the system is configured as an 800XD or 400XD. This command will return "HPR800XD" in place of "HPR400XD" when the secondary power supply is connected and the power is on. Data: None Return value: String identifying the system Sample: >00090< >000HYPERFORMANCE130MANUALB5< or >000HYPERFORMANCE130AUTO30< or >000HYPERFORMANCE130AUTOMIX1E<
001	VERSION	Manual gas system Auto gas system	Get the version of the power supply firmware. Data: None Return value: Power supply firmware then Gas console firmware, space-delimited Sample: >00191< >001A.0 A.25< (power supply rev A, gas rev A)
002	GET_STATE	Manual gas system Auto gas system	Get the current state of the plasma system. Data: None Return value: Status code (see table V) Sample: >00292< >002000052< (status code 0)
003	LAST_ERROR	Manual gas system Auto gas system	Get the last error that occurred at the system. Data: None Return value: Error code (see table IV) Sample: >00393< >00301165B< (error code 116)
004	REMOTE_MODE	Manual gas system Auto gas system	Switch system into remote mode, to allow remote control of the plasma system. Data: None Return value: 1 = accepted, 0 = not accepted Sample: >00494< >0041C5<

Command table (2 of 14)

ID	Command	System	Description
028	READ_PLASMA_AMPS	Manual gas system Auto gas system	Read actual power supply current. Data: None Return value: Power supply current in amps Sample: >0289A< >02801305E< (130 amps)
058	SET_NOMINAL_AMPS	Auto gas system	Set the power supply current in amps. Data: 5-260 Amps (Limited to 130 amps on the HPR130) Return value: Actual current value set Sample: >05813031< >058013061< (set 130 amps)
064	GAS_PREFLOW_TEST_START	Manual gas system Auto gas system	Turn on the preflow gases. Not allowed when cutting. Data: None Return value: 1 = accepted, 0 = not accepted Sample: >0649A< >0641CB<
065	GAS_PREFLOW_TEST_STOP	Manual gas system Auto gas system	Turn off the preflow gases. Not allowed when cutting. Data: None Return value: 1 = accepted, 0 = not accepted Sample: >0659B< >0651CC<
066	GAS_CUTFLOW_TEST_START	Manual gas system Auto gas system	Turn on the cutflow gases. Not allowed when cutting. Data: None Return value: 1 = accepted, 0 = not accepted Sample: >0669C< >0661CD<
067	GAS_CUTFLOW_TEST_STOP	Manual gas system Auto gas system	Turn off the cutflow gases. Not allowed when cutting. Data: None Return value: 1 = accepted, 0 = not accepted Sample: >0679D< >0671CE<)

Command table (3 of 14)

ID	Command	System	Description
068	SYSTEM_RESET	Manual gas system Auto gas system	Clear error conditions and resume operation. Only accepted if system is in a shutdown error condition (Error code > 79 and State = 14). Data: None Return value: 1 = accepted, 0 = not accepted Sample: >0689E< >0681CF<
070	SET_CORNER_CURRENT	Manual gas system Auto gas system	When CORNER CURRENT input is activated the power supply will switch to the current percentage specified. Data: % of cutting current (50-100%) 50=50% Return value: % achieved Sample: >0707503< >070007563< (set 75%)<
071	MANUAL_PUMP_CONTROL	Manual gas system Auto gas system	Used to override software control of the coolant pump. If the system has a fatal error, the pump cannot be overridden. Data: 1 = override software to force pump on, 0 = system software controls the pump, override off Return value: 1 = accepted, 0 = not accepted Sample: >0711C9< >0711C9<
072	GET_CONTROL_VOLTAGE	Manual gas system Auto gas system	Returns the internal control voltage of the power supply Data: None Return value: Voltage (1/10 V) 1200 = 120.0 V Sample: >07299< >07212005C< (120.0 volts)

Command table (4 of 14)

ID	Command	System	Description
074	GET_IO_STATUS	Manual gas system Auto gas system	<p>Read the status of the I/O ports of the DSP. Refer to I/O listing for description of each bit in Ports A-F.</p> <p>Data: None</p> <p>Return value: PA00000000 PB00000000 PC00000000 PD00000000 PE00000000 PF00000000</p> <p>Ports A-F are returned space-delimited. The numbers are the decimal representation of the binary value of the port. 1 = on, 0 = off.</p> <p>Sample: >0749B< >074PA00000100 PB00000000 PC00010101 PD00100000 PE00010000 PF10000000B7<</p>
078	SET_ALL_GAS_FLOWS	Auto gas system	<p>Set all gas flow rates.</p> <p>N₂ mix setpoint and Gas 2 mix setpoint are only applicable when using a mixed plasma gas such as H35 – N₂. Otherwise, these 2 values should be set to 0.</p> <p>A value of 0 for N₂ mix setpoint will cause the system to close SV12, the solenoid valve for N₂ mixing. A value of 0 for Gas 2 Mix Setpoint will cause the system to close SV13 and open SV14. This will cause the inlet gas to bypass motor valve 2 and pass directly to the outlet of the mixing console.</p> <p>Data: Space-delimited: Plasma cutflow (0 – 99 psi), Plasma preflow (0 – 99 psi), Shield cutflow (0 – 99 psi), Shield preflow (0 – 99 psi), N₂ mix setpoint (0 – 100 psi), Gas2 mix setpoint (0 – 100 psi).</p> <p>Return value: 1 = accepted, 0 = not accepted</p> <p>Sample: >07855 45 35 25 50 50AB< >0781D0<</p>

Command table (5 of 14)

ID	Command	System	Description
079	GET_PS_INFO	Manual gas system Auto gas system	Returns pressures, system state, and system error, space-delimited Data: None Return value: Plasma cutflow pressure (0044 = 44 psi) Plasma preflow pressure (0044 = 44 psi) Shield cutflow pressure (0044 = 44 psi) Shield preflow pressure (0044 = 44 psi) Current setpoint (amps) System state (see table V) (0003 = state 3) System error (see table IV) (0000 = error 0) Cut gas 1 pressure (0044 = 44 psi) Cut gas 2 pressure (0044 = 44 psi) N ₂ Mix inlet pressure (0044 = 44 psi) Gas2 Mix inlet pressure (0044 = 44 psi) Note: Cut gas 1, Cut gas 2, N ₂ mix inlet, and Gas 2 mix inlet are not measured in the manual gas console configuration. Sample: >079A0< >079PC0044 PP0042 SC0034 SP0035 CS0040 ST0003 ER0000 CG0000 CG0000 MV0000 MV0000DE<
084	DOWNLOAD_SOFTWARE Not currently implemented on the HD4070 or the HPR systems	TBD	Download new firmware to the plasma system. Data: TBD Return value: 1 = packet accepted, 0 = not accepted Sample: TBD
085	WAKE	Manual gas system Auto gas system	This command is used to wake a system and enable its transmitter to communicate on a multi drop line. Data: System ID, which is set by dipperswitches on PC board. Return value: Echo of the command Sample: >0850CD< >0850CD<
086	SLEEP	Manual gas system Auto gas system	Tell all systems on the line to disconnect their transmitters Data: None Return value: None Sample: >0869E< No response

Command table (6 of 14)

ID	Command	System	Description
087	BROADCAST MODE	Manual gas system Auto gas system	Tell all systems to listen but not respond. Data: None Return value: None Sample: >0879F< no response
094	READ_GAS_PRESSURES	Manual gas system Auto gas system	Read the gas pressures. Data: None Return value: Plasma cutflow pressure (psi), Plasma preflow pressure (psi), Shield cutflow pressure (psi), Shield preflow pressure (psi), Cut gas 1 pressure (psi), Cut gas 2 pressure (psi), N ₂ Mix inlet pressure (psi), Gas2 Mix inlet pressure (psi) space-delimited Values are in psi (0007 = 7 psi) Sample: >0949D< >094PC0007 PP0036 SC0016 SP0003 CG0000 CG0000 MV0000 MV00005D<
095	SET_ALL_PARAMETERS	Auto gas system	Set all variables to run the plasma system. If inlet gases change power supply will enter the purge state. Gas type changes are not allowed when the system is cutting (state 4 – state 10). N ₂ mix setpoint and Gas 2 mix setpoint are only applicable when using a mixed plasma gas such as H35 – N ₂ otherwise these 2 values should be set to 0. A value of 0 for N ₂ Mix setpoint will cause the system to close SV12, the solenoid valve for N ₂ mixing. A value of 0 for Gas 2 Mix Setpoint will cause the system to close SV13 and open SV14. This will cause the inlet gas to bypass motor valve 2 and pass directly to the outlet of the mixing console. Data: Current setpoint (5 – 130/260/400 amps), Corner current percent (50 - 100%), Plasma gas type code (use table VI), Shield gas type code (use table VI), Plasma cutflow setpoint (0 – 99 psi), Plasma preflow setpoint (0 – 99 psi), Shield cutflow setpoint (0 – 99 psi), Shield preflow setpoint (0 – 99 psi), N ₂ mix setpoint (0 – 100 psi), Gas 2 mix setpoint (0 – 100 psi), space-delimited. Return value: 1= accepted, 0 = not accepted Sample: >095100 75 1 6 55 45 35 25 00 0084< >0951CF<

Command table (7 of 14)

ID	Command	System	Description
096	SET_INLET_GASES	Auto gas system	<p>Set inlet gases for auto console. If inlet gases change, the power supply will enter the purge state. Gas type changes are not allowed when the system is cutting (state 4 – state 10).</p> <p>Data: Plasma gas type code (See table VI), Shield gas type code (See table VI), space-delimited.</p> <p>Return value: 1 = accepted, 0 = not accepted</p> <p>Sample: >0961 626< (Set plasma gas = O₂ and set shield gas = N₂) >0961D0<</p>
097	READ_CORNER_CURRENT	Manual gas system Auto gas system	<p>Read the corner-current percentage</p> <p>Data: None</p> <p>Return value: Percentage</p> <p>Sample: >097A0< >09700756C< (75%)</p>
098	GET_INLET_GASES	Manual gas system Auto gas system	<p>Read the inlet gas types</p> <p>Data: None</p> <p>Return value: Plasma gas type code (See table VI), Shield gas type code (See table VI), space-delimited</p> <p>Sample: >098A1< >0980001 000648< (Plasma gas = O₂ and shield gas = N₂)</p>
099	GET_GAS_FLOWS	Auto gas system	<p>Read the gas setpoints</p> <p>Data: None</p> <p>Return value: Plasma cutflow setpoint (psi), Plasma preflow setpoint (psi), Shield cutflow setpoint (psi), Shield preflow setpoint (psi), N₂ Mix setpoint (psi), Gas 2 mix setpoint (psi) space-delimited. (55 = 55 psi)</p> <p>Sample: >099A2< >0990055 0045 0035 0025 0050 0050EE<</p>

Command table (8 of 14)

ID	Command	System	Description
100	GET_CONTROL_DATA	Manual gas system Auto gas system	<p>Read internal control data: Chopper A used in HPR130/HPR260 Chopper B used in HPR260</p> <p>Return string is the same whether the system is an HPR130 or HPR260. Chopper B data can be ignored for HPR130.</p> <p>Chopper A temp (raw A/D, 0 - 1023), Chopper B temp (raw A/D, 0 - 1023), Line voltage (1/10 volts, 0 - 2400), 240.0 vac Coolant flow (1/100 gpm, 0 - 440), 4.40 gpm Coolant temp (raw A/D, 0 - 1023), Transformer temp (raw A/D, 0 - 1023), Chopper A current (0 – 130 amps), Chopper B current (0 – 130 amps), Work lead current (0 – 130/260 amps), Chopper A setpoint (5 – 130 amps), Chopper B setpoint (5 – 130 amps), PWM chopper A (100% = 1070), PWM chopper B (100% = 1070).</p> <p>Data: None</p> <p>Return value: Above info is space-delimited.</p> <p>Sample: >10091< >100CAT0482 CBT0021 LVO0118 CFL0009 CTP0481 TTP0481 CAC0001 CBC0014 WLC0005 CAS0000 CBS0534 PWMA0000 PWMB00000B<</p>
101	SET_IO_STATUS	Manual gas system Auto gas system	<p>This command will allow the user to turn on or off each output of the processor. After sending this command, the SYSTEM_RESET command must be issued to restore the processor state. The I/O are in the following order:</p> <p>Data: 1 = On, 0 = Off for each I/O point</p> <p>Return value: 1 = accepted, 0 = not accepted</p> <p>Power Supply Pilot arc Relay Marking surge relay Pilot arc enable Coolant pump motor Soft-start enable CNC error CNC ramp-down error Igniter Contactor CNC machine motion CNC spare output Spare output</p> <p>Sample: >1011111111111111DD< = All outputs on >1011C3<</p>

Command table (11 of 14)

ID	Command	System	Description
121	LEAK_CHECK_MODE	Manual gas system Auto gas system	<p>This command will put the system into leak mode. There are 3 modes, mode #1 is the inlet leak check mode. This is used to see if the inlet solenoids are allowing gas to pass through the valve even when they are closed.</p> <p>Mode #2 is the system leak check mode which will test for leaks to atmosphere within the system. Mode #3 is the Burkert valve flow test. For automatic gas consoles only.</p> <p>For the inlet leak test, the system should have 0 psi on all gas channels, and hold at this pressure.</p> <p>For the system leak test, the system should charge all gas lines, then hold the pressure.</p> <p>The Burkert flow test checks for an expected PWM value for a set pressure and does a gas ramp-down test.</p> <p>NOTE: This test is preformed using 130 amp O₂ / Air consumables and setting the 30 amp O₂ / O₂ process</p> <p>Each test takes about 40 seconds to complete.</p> <p>This command will only be accepted when the power supply is in the state IDLE2 (03).</p> <p>After leak checking is complete the system must be set to mode 0.</p> <p>An error code will reflect the state of the test. Using the GET_LAST_ERROR command, you can get the result of the test.</p> <p>12 = Test in progress 13 = Test passed 14 = Cut gas channel #1 failed 15 = Cut gas channel #2 failed 16 = Plasma ramp-down test failed (Burkert test only) 17 = Shield ramp-down test failed (Burkert test only)</p> <p>Data: Mode 0 = run 1 = Inlet leak check 2 = System leak check 3 = Burkert flow check</p> <p>Return value: Time for the test to run in seconds, 0 = not accepted</p> <p>Sample: >1211C5< >12140F8< "40 second test"</p>

Command table (12 of 14)

ID	Command	System	Description
122	READ_GAS_SWITCH	Manual gas system	<p>This command will return data that shows the actual position of the rotary switches used to set the inlet gas type.</p> <p>The difference between this command and 098 is that this command returns the values set by the position of the switch. The 098 command returns values that the software decides are acceptable gas combinations. For example, H35 plasma and O₂ shield is not acceptable and is overridden by the software to be H35 plasma and N₂ shield regardless of the position of the shield gas knob. In this case, the 098 command would return H35 N₂. This command will return H35 O₂.</p> <p>Data: None</p> <p>Return value: Plasma gas type code (See table VI), Shield gas type code (See table VI), space-delimited</p> <p>Sample: >12295< >1220001 00063C<</p>
124	INDEX_MOTORVALVES	Auto gas system	<p>Move the motor valve by a fixed number of ADC counts</p> <p>Data: Motor Valve number (1 or 2) Open/Clos (0 = Close, 1 = Open) Multiplier (move by x10 counts, 3 = move 30 counts)</p> <p>Return value: 1 = accepted</p> <p>Sample: Open Motor valve 1 by 30 counts >1241 1 36C< >1241C8<</p>
125	GET_TIMER_COUNTER	Manual gas system Auto gas system	<p>Read Timer/Counter data from the power supply</p> <p>Data: None</p> <p>Return value: Arc-on time (seconds) System on time (minutes) Total starts (# of arc transfers) Total starting errors (failed to transfer) Total ramp-down errors (failed to ramp-down current) Write counter (# of writes to the present memory block – for diagnostics only) Memory block (current memory location for timer counter data – for diagnostics only)</p> <p>All fields are a fixed width of 7 numbers followed by a space.</p> <p>Sample: >12598< >1250000000 0000000 0000000 0000000 0000000 0000000 0000000 58<</p>

Command table (13 of 14)

ID	Command	System	Description
126	GET_INFO2	Auto gas control board only	See 079
127	GET_INFO3	Auto gas control board only	See 079
131	CLEAR WARNINGS	Manual gas system Auto gas system	This command will clear error codes less than #43. Sample: >13195< >1311C6<
132	READ COOLANT PRESSURE	HPR260 ONLY	This command returns the raw A/D value for coolant pressure. 83 counts = 225 psi 73 counts = 200 psi Sample: >13296< >13280FE<
133	GET CONTROL DATA3	HPR400XD ONLY	This command provides data for the 3rd and 4th choppers used in the HPR400 system. Chopper C temp (raw A/D) Chopper D temp (raw A/D) Chopper C current (amps) Chopper D current (amps) Data: None Return value: Above info space-delimited. Sample: >13397< >133CCT0482 CDT0021 CCC0000 CDC000050<
134	READ ERROR LOG	ALL HPR SYSTEMS	This command will return the last 4 error codes the system encountered. The log will only record errors (error code values greater than 0). It ignores error code 0, which indicates no error or that an error has been cleared. The error codes are listed space-delimited, most recent error first. Data: None Return value: Error – most recent (see table IV Error Codes) Error #2 Error #3 Error – oldest error Sample: >13498< >134020 020 024 0534A<

Command table (14 of 14)

ID	Command	System	Description
136	SERIAL_RESPONSE_DELAY	All HPR systems	<p>Used when a CNC serial port can only support a half-duplex connection. The HPR power supply will reduce its response speed.</p> <p>Data:</p> <p>None</p> <p>Return value:</p> <p>1 if successful</p> <p>Sample:</p> <p>Send >1369A<, response >1361CB<</p>
158	GET_SECONDARY_VERSION	HPR800XD ONLY	<p>Get the software version of the secondary power supply</p> <p>Data:</p> <p>None</p> <p>Return value:</p> <p>The Secondary Power Supply software version</p> <p>ex."D.0". "0.0" is returned if no secondary power supply is connected and the power is on.</p> <p>sample:</p> <p>>1589E<</p> <p>>158D.040<</p>

Error responses

If there is a problem with the serial command, the module will return an error.

Bad checksum

Return ID: 500

Description: The serial command received does not have the correct checksum.

Sample: >00091< – checksum should be 90, not 91
>50095< – bad checksum

Bad command

Return ID: 501

Description: If the module does not recognize the command ID, it will return ID 501.

Sample >999AB< – unknown ID
>50196< – bad command

Calculating checksums

Checksum is calculated on the command ID and command data only.

HELLO Command: >00090<

0 = 0x30 (ASCII value for number 0)

0 = 0x30

0 = 0x30

Checksum = 0x30 + 0x30 + 0x30 = 90

READ INPUTS power supply response: >107000058<

1 = 0x31

0 = 0x30

7 = 0x37

0 = 0x30

0 = 0x30

0 = 0x30

0 = 0x30

Checksum = 0x31 + 0x30 + 0x37 + 0x30 + 0x30 + 0x30 + 0x30 = 0x158

We only use the 2 least significant digits so the checksum = 58

Error codes

ID	Name	Description
000	NO ERROR	System is ready to run.
009	FLOW SWITCH TEST	When the pump is restarted after a pump timeout (30 minutes without a start signal) the system will test the flow switch to make sure there is sufficient flow before firing the torch.
011	NO_ACTIVE_PROCESS	The power supply receives an invalid current setting from a CNC.
012	TEST IN PROGRESS	One of the gas test modes is running.
013	TEST PASSED	The test completed successfully.
014	CUT GAS CHANNEL #1 FAIL	The gas pressure is dropping on channel #1, indicating a leak.
015	CUT GAS CHANNEL #2 FAIL	The gas pressure is dropping on channel #2, indicating a leak.
016	PLASMA RAMP-DOWN FAIL	Pump output has exceeded 200 psi.
017	SHIELD RAMP-DOWN FAIL	Shield pressure did not decrease in the allotted time.
018	PUMP OVER PRESSURE	Pump output has exceeded 13.79 bar (200 psi.)
020	NO PILOT ARC	No current detected from chopper at ignition and before 1-second timeout.
021	NO ARC TRANSFER	No transfer signal detected before 500-msec timeout.
024 Primary 224 Secondary	LOST CURRENT CH1	After transfer, lost the chopper current signal.
025 Primary 225 Secondary	LOST CURRENT CH2	After transfer, lost the chopper current signal.
026 Primary 226 Secondary	LOST TRANSFER	After transfer, lost the transfer signal.
027 Primary 227 Secondary	LOST PHASE	When main contactor is engaged, no "phase OK" input.
028 Primary 228 Secondary	LOST CURRENT CH3	After transfer, lost the chopper current signal.
030	GAS SYSTEM ERROR	A failure has occurred in the gas system.
031 Primary 231 Secondary	START LOST	Start signal was removed before steady-state operation.
032	HOLD TIMEOUT	Hold signal was applied for longer than 60 seconds.
033	PRE CHARGE TIMEOUT	Gas console was not able to charge the gas lines to the correct pressure.
034 Primary 234 Secondary	PRE CHARGE TIMEOUT	Gas console was not able to charge the gas lines to the correct pressure.
042	LOW NITROGEN PRESSURE	Nitrogen gas pressure under lower limit of 2.07 bar (30 psi) – cutting, 0.34 bar (5 psi) – marking
044	LOW PLASMA GAS PRESSURE	Gas pressure under lower limit of 0.34 bar (5 psi) – pre-flow 3.45 bar (50 psi) – cutflow (cutting) 0.34 bar (5 psi) – cutflow (marking).
045	HIGH PLASMA GAS PRESSURE	Gas pressure over upper limit of 7.58 bar (110 psi).
046	LOW LINE VOLTAGE	Line voltage is under lower limit of 102 VAC (120 VAC -15%).
047	HIGH LINE VOLTAGE	Line voltage is over upper limit of 138 VAC (120 VAC +15%).
048 Primary 248 Secondary	CAN ERROR	An error occurred with the CAN communication system.
050 Primary 250 Secondary	START ON AT INIT	Start signal input is active during power-up.
053	LOW SHIELD GAS PRESSURE	Gas pressure is under lower limit of 0.14 bar (2 psi).

APPENDIX B – CNC INTERFACE PROTOCOL

ID	Name	Description
054	HIGH SHIELD GAS PRESSURE	Gas pressure is over upper limit of 7.58 bar (110 psi).
055	MV 1 INLET PRESSURE	Motor valve 1 inlet pressure is less than 3.45 bar (50 psi) or greater than 9.65 bar (140 psi).
056	MV 2 INLET PRESSURE	Motor valve 2 inlet pressure is less than 3.45 bar (50 psi) or greater than 9.65 bar (140 psi).
057	CUT GAS 1 PRESSURE	In the selection console, cut gas 1 outlet pressure is less than 3.45 bar (50 psi) or greater than 9.65 bar (140 psi).
058	CUT GAS 2 PRESSURE	In the selection console, if cut gas 2 outlet pressure is less than 3.45 bar (50 psi) for non-mixing, or less than 1.38 bar (20 psi) when mixing or greater than 9.65 bar (140 psi) for non-mixing and mixing.
060	LOW COOLANT FLOW	Coolant flow is less than the required 2.3 lpm (0.6 gpm).
061	NO PLASMA GAS TYPE	Plasma gas has not been selected.
062	NO SHIELD GAS TYPE	Shield gas has not been selected, or system is in test mode.
065 Primary 265 Secondary	CHOPPER1 OVERTEMP	Chopper #1 overheated.
066 Primary 266 Secondary	CHOPPER2 OVERTEMP	Chopper #2 overheated.
067 Primary 267 Secondary	MAGNETICS OVERTEMP	Transformer has overheated.
071	COOLANT OVERTEMP	Torch coolant has overheated.
072	AUTOMATIC GAS CONTROL BOARD OVERTEMP	Control board has exceeded 90° C (194° F).
073 Primary 273 Secondary	CHOPPER3 OVERTEMP	Chopper #3 overheated
074 Primary 274 Secondary	CHOPPER4 OVERTEMP	Chopper #4 overheated
075 Primary 275 Secondary	CURRENT TOO LOW ON LEM #3	A current less than 10 amps has been detected by current sensor 3.
076 Primary 276 Secondary	CURRENT TOO LOW ON LEM #4	A current less than 10 amps has been detected by current sensor 4.
093	NO COOLANT FLOW	Coolant flow is less than 0.6 gpm.
095	CURRENT TOO HIGH ON LEM #4	Current has exceeded 35 amps during the chopper test
099 Primary 299 Secondary	CHOPPER1 OVERTEMP AT INIT	Chopper #1 is indicating overtemp during power-up.
100 Primary 300 Secondary	CHOPPER2 OVERTEMP AT INIT	Chopper #2 is indicating overtemp during power-up.
101 Primary 301 Secondary	MAGNETICS OVERTEMP AT INIT	Transformer is indicating overtemp during power-up.
102 Primary 302 Secondary	OUTPUT CURRENT AT INIT	Chopper current signal is active on power-up.
103 Primary 303 Secondary	CURRENT TOO HIGH ON LEM #1	A current greater than 35 amps has been detected by current sensor 1.
104 Primary 304 Secondary	CURRENT TOO HIGH ON LEM #2	A current greater than 35 amps has been detected by current sensor 2.
105 Primary 305 Secondary	CURRENT TOO LOW ON LEM #1	A current less than 10 amps has been detected by current sensor 1.

APPENDIX B – CNC INTERFACE PROTOCOL

ID	Name	Description
106 Primary 306 Secondary	CURRENT TOO LOW ON LEM #2	A current less than 10 amps has been detected by current sensor 2.
107 Primary 307 Secondary	CURRENT TOO HIGH ON LEM #3	A current greater than 35 amps has been detected by current sensor 3.
108 Primary 308 Secondary	TRANSFER AT INIT	The system has detected current on the work lead during power-up.
109	COOLANT FLOW AT INIT	Coolant flow is greater than 1.14 lpm (0.3 gpm) when pump is off.
111	COOLANT OVERTEMP AT INIT	Coolant is indicating overtemp during power-up.
116 Primary 316 Secondary	WATCHDOG INTERLOCK	CAN communication error.
123	MV 1 ERROR	Motor valve 1 did not move into position within 60 seconds.
124	MV 2 ERROR	Motor valve 2 did not move into position within 60 seconds.
133	UNKNOWN GAS CONSOLE TYPE	The power supply control board does not recognize the gas console installed or has not received a CAN message identifying the type of console installed.
134 Primary 334 Secondary	CHOPPER 1 OVERCURRENT	Chopper 1 current feedback has exceeded 160 amps.
138 Primary 338 Secondary	CHOPPER 2 OVERCURRENT	Chopper 2 current feedback has exceeded 160 amps.
139	PURGE TIMEOUT ERROR	The purge cycle did not complete within 3 minutes.
140	AUTO GAS PRESSURE TRANSDUCER #1 ERROR	Faulty transducer or auto gas control PCB
141	AUTO GAS PRESSURE TRANSDUCER #2 ERROR	Faulty transducer or auto gas control PCB
142	AUTO GAS PRESSURE TRANSDUCER #3 ERROR	Faulty transducer or auto gas control PCB
143	AUTO GAS PRESSURE TRANSDUCER #4 ERROR	Faulty transducer or auto gas control PCB
144	MANUAL GAS CONSOLE INTERNAL FLASH MEMORY ERROR	Replace manual gas console control PCB
145	AUTOMATIC GAS CONSOLE INTERNAL FLASH MEMORY ERROR	Replace auto gas console control PCB
146 Primary 346 Secondary	CHOPPER #3 OVERTEMP AT INIT	Chopper #3 is indicating over temp during power-up
147 Primary 347 Secondary	CHOPPER #4 OVERTEMP AT INIT	Chopper #4 is indicating over temp during power-up
151 Primary 351 Secondary	SOFTWARE FAIL	Software has detected an incorrect state or condition.
152	INTERNAL FLASH ERROR	DSP memory is not working properly.
153	PS EEPROM ERROR	EEPROM memory on power supply board not working.
154 Primary 354 Secondary	CHOPPER 3 OVER CURRENT	Chopper 3 current feedback has exceeded 160 amps
155 Primary 355 Secondary	CHOPPER 4 OVER CURRENT	Chopper 4 current feedback has exceeded 160 amps

APPENDIX B – CNC INTERFACE PROTOCOL

ID	Name	Description
156 Primary 356 Secondary	CHOPPER 2 CURRENT AT INIT	Chopper 2 current signal is active on power-up
157 Primary 357 Secondary	CHOPPER 3 CURRENT AT INIT	Chopper 3 current signal is active on power-up
158 Primary 358 Secondary	CHOPPER 4 CURRENT AT INIT	Chopper 4 current signal is active on power-up
159 Primary 359 Secondary	MOTOR DRIVE FAULT	Motor drive board power module is indicating an alarm – this can be comparable to “blowing a fuse” – does not necessarily indicate a problem with the board.
160	HPR COOLER CAN FAULT	Communications between the control board and the pump/motor drive board was interrupted for greater than 1 second.
161	MAXIMUM COOLANT FLOW EXCEEDED	Coolant flow has exceeded 6.8 lpm (1.8 gpm) for a cooler, 8.52 lpm (2.25 gpm) for a chiller.
180	SELECTION CONSOLE CAN TIMEOUT	Power supply has not received a CAN message from the selection console within 1 second
181	METERING CONSOLE CAN TIMEOUT	Power supply has not received a CAN message from the metering console within 1 second
182	SECONDARY POWER SUPPLY TIMEOUT	The secondary power supply fails before transmitting the error to the primary power supply.
383	SECONDARY POWER SUPPLY TIMEOUT	The secondary power supply is ready to provide current output but does not receive the control signal from the primary power supply.

Status codes

ID	Name
00	IDLE
02	PURGE
03	IDLE2
04	PREFLOW
05	PILOT ARC
06	TRANSFER
07	RAMP-UP
08	STEADY STATE
09	RAMP-DOWN
10	FINAL RAMP-DOWN
11	AUTO OFF
12	TEST CUTFLOW
14	SHUTDOWN
15	RESET
16	MAINTENANCE
20	TEST PREFLOW
22	MANUAL PUMP CONTROL
23	INLET LEAK CHECK
24	SYSTEM LEAK CHECK
25	BURKERT FLOW CHECK

Gas type codes

ID	Gas type
0	No gas
1	Oxygen
2	Methane (CH ₄) not supported
3	H35 (argon – hydrogen)
4	H5 (not supported)
5	Air
6	Nitrogen
7	Argon
8	F5 (N95)

CNC requirements

Auto gas console

Below is a list of functionality that CNCs must offer for the automatic gas console version of the HPR system. In this system configuration there is no local control of the plasma system. All settings and diagnostic information will be under CNC control.

1. Display and adjust the current setpoint – cutting current, see command ID No. 95
2. Display and adjust the plasma preflow setpoint – pressure setting, see command ID No. 95
3. Display and adjust the plasma cutflow setpoint – pressure setting, see command ID No. 95
4. Display and adjust the shield preflow setpoint – pressure setting, see command ID No. 95
5. Display and adjust the shield cutflow setpoint – pressure setting, see command ID No. 95
6. Display and adjust the plasma gas type – inlet gas selection, see command ID No. 95
7. Display and adjust the shield gas type – inlet gas selection, see command ID No. 95
8. Display and adjust the gas mixing setpoint – pressure setpoint, see command ID No. 95
9. Display the system error code – error code numbers, see command ID No. 3
10. Display the system status code – status code numbers, see command ID No. 2
11. Manual pump control – manually turn on/off the pump, see command ID No. 71
12. Display the firmware version – version of power supply and gas console firmware, see command ID No. 1
13. Test preflow gases – put the system in test gas mode, see command ID No. 64, 65
14. Test cutflow gases – put the system in test gas mode, see command ID No. 66, 67
15. Power on/off – turn on/off the plasma system, not a serial command (active low, dry contact, opto-isolated)
16. Display line voltage – see command ID No. 100
17. Display chopper current(s) – see command ID No. 100
18. Display work lead current – see command ID No. 100
19. Display chopper temperature(s) – see command ID No. 100
20. Display transformer temperature – see command ID No. 100
21. Display gas pressures – see command ID No. 79
22. Display coolant flow rate – see command ID No. 100

Serial interface guidelines

Checksum

The protocol used for the serial interface between the Hypertherm system and the CNC contains a checksum on the message being sent. The checksum should be validated for each message to ensure the information is not corrupted.

Message retries

We recommend retrying a message if the original message was not acknowledged by the system. This is especially important when the high-frequency ignition is active. The high-frequency ignition can be active for up to 1 second and can corrupt serial communications. It is important to space the retries so that the system can handle an interruption in serial communications for up to 1 second.

Another alternative to handling the high frequency ignition is to poll for the power supply state, using the GET_STATE command. If the state is (5 – Pilot arc) then stop serial communications until the state is no longer (5 – Pilot arc).

Cable shielding

We have chosen to use metal shell DB style machine/serial interface cables on some on the newer systems. One of the reasons this type of cable was selected is for their EMI shielding capabilities. It is important that integrity of the shielding of this cable be maintained. The shielding provides protection from the high-frequency ignition system, if the cable shields are not properly terminated then the protection is not as effective. This is best achieved by ensuring the shield has a 360° termination provided on both end of the cables. Using a drain wire will not achieve the proper shielding. The cable should also be as short as possible with no coils.

This page is blank intentionally

ROBOTIC APPLICATIONS

In this section

Components for robotic applications.....c-2

- Torch leadsc-2
- Ohmic contact extension.....c-2
- Rotational mounting sleeve (optional) – 220864c-3
- Leather over wrap – 024866c-3
- Robotic teaching torch (laser pointer) – 228394.....c-3
- Torch and rotational mounting sleeve dimensions.....c-3
- Rotational mounting sleeve clamp dimensions.....c-4

Components for robotic applications

Torch leads

The torch leads listed below have been designed to withstand the added stresses found in robotic, or bevel, applications. They are available with 2 m (6 ft), or 2.5 m (8 ft) gas leads.

Note: Consumable life will be reduced if the 2.5 m (8 ft) gas leads are used.

Overall length	1.8 M (6 feet) gas lead	2.4 M (8 feet) gas lead
2 m (6 ft)	228514	228516
2.5 m (8 ft)	228515	228517
3 m (10 ft)	228475	228482
3.5 m (12 ft)	228476	228483
4.5 m (15 ft)	228477	228484
6 m (20 ft)	228478	228485
7.5 m (25 ft)	228479	228486
10 m (35 ft)	228480	228487
15 m (50 ft)	228481	228488

Ohmic contact extension

A 2.5 m (8 ft) Ohmic contact wire is part of the lead set. Extensions can be found in the table below

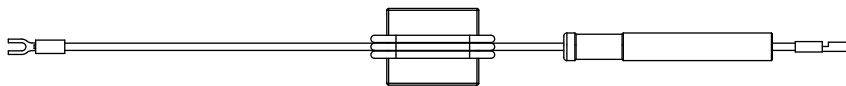

Part number	Length	Part number	Length
223059	1.5 m (5 ft)	223064	12 m (40 ft)
223060	3 m (10 ft)	223065	15 m (50 ft)
223061	4.5 m (15 ft)	223066	22.5 m (75 ft)
223062	6 m (20 ft)	223067	30 m (100 ft)
223063	9 m (30 ft)	223068	45 m (150 ft)

Rotational mounting sleeve (optional) – 220864

The rotational sleeve is designed for use in applications where the torch leads are twisted repeatedly. It is an optional component, and does not need to be used to use the torch leads listed above. The length of the rotational sleeve is 114.3 mm (4.5 in).

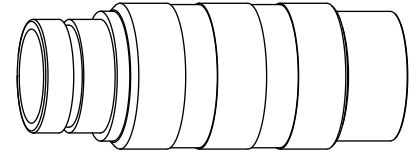

Rotational mounting sleeve clamp – 220900

The rotational sleeve has a larger diameter than standard sleeves (57 mm/2.25 in).

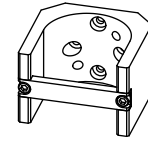

Leather over wrap – 024866

The leather over wrap is 3 m (10 ft) long, and is designed to be installed over the leads from where they attach to the torch. This adds protection in applications where molten metal will splash back on the leads.

Robotic teaching torch (laser pointer) – 228394

- Mount the laser pointer in the torch sleeve to provide accurate positioning and alignment of the torch.
- Use for online programming/teaching and robotic alignment systems.

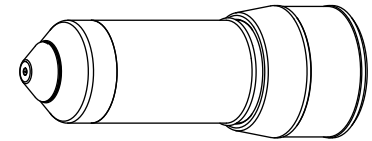

Torch and rotational mounting sleeve dimensions

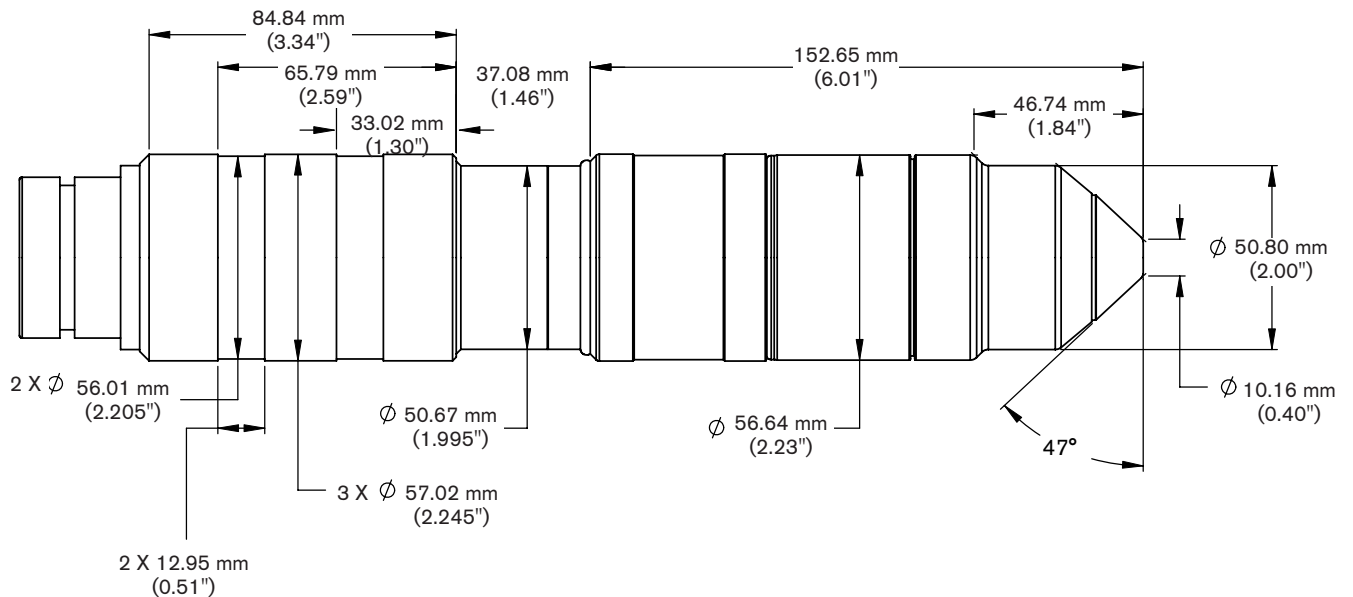

Rotational mounting sleeve clamp dimensions

